

KWC AVA 2.0

Trim kit, with safety device DIN EN 1717 – Lever mixer – Tub

Modell-Linie: AVA 2.0 | 20.464.550.000

Showers | Exposed bath mixer

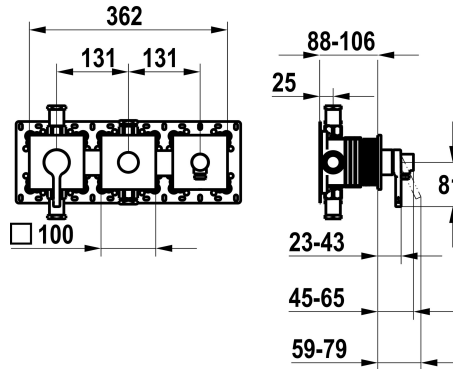

KWC-No.

125293

chromeline, trim kit, with safety device DIN EN 1717

NEW

* Trim kit with function unit KWC HOMEBOX

* Outflow with integrated hose connection above or below for the second consumer with CHOICE diverter without automatic reset

* KWC cartridge M 35-S HF

- with ceramic discs
- flow rate and temperature continuously variable

* Scope of delivery:

- Lever mixer unit
- Diverter unit
- Hose connection unit
- Fastening of the cover plate without screws

* To be ordered separately:

- Unit for concealed installation KWC HOMEBOX Thermostatic/ lever mixer 2 consumers 39.006.261.931

Technical Data

Flow rate
Handling
Color code
Installation_type
Faucet_typ
Concealed unit

20 l/min (3bar)
3-Lamps
chrome
2-Screens, monitors etc
Lever mixer
4-Large equipment

Spare Parts



Cartridge M 35-S HF

537602

Z.537.602