

KWC ELLA

Trim kit, with safety device DIN EN 1717 – Lever mixer – Tub

Modell-Linie: ELLA | 20.384.550.000
Duschar | Badkarsarmaturer

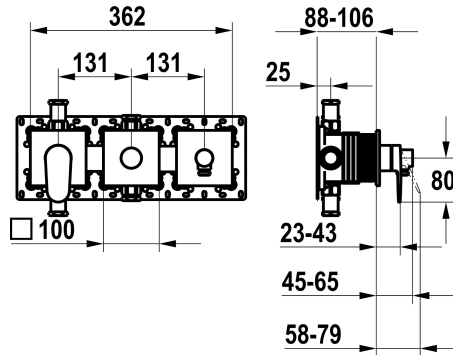

KWC-No.

125296
chromeline, trim kit, with safety device DIN EN 1717

- * Trim kit with function unit KWC HOMEBOX
- * Outflow with integrated hose connection above or below for the second consumer with CHOICE diverter without automatic reset
- * KWC cartridge M 35-S HF
 - with ceramic discs
 - flow rate and temperature continuously variable

- * Scope of delivery:
 - Lever mixer unit
 - Diverter unit
 - Hose connection unit
 - Fastening of the cover plate without screws
- * To be ordered separately:
 - Unit for concealed installation KWC HOMEBOX Thermostatic/ lever mixer 2 consumers 39.006.261.931



Technical Data

ATT-KWC-A_ABGANG_UP	20 l/min (3bar)
Handling	3
ATT-KWC-FARBCODE	F000
Installation_type	2
Faucet_typ	01
ATT-KWC-UNTERPUTZ	4

Reservdelar



Cartridge M 35-S HF

537602
Z.537.602