

PROTRONIC-S

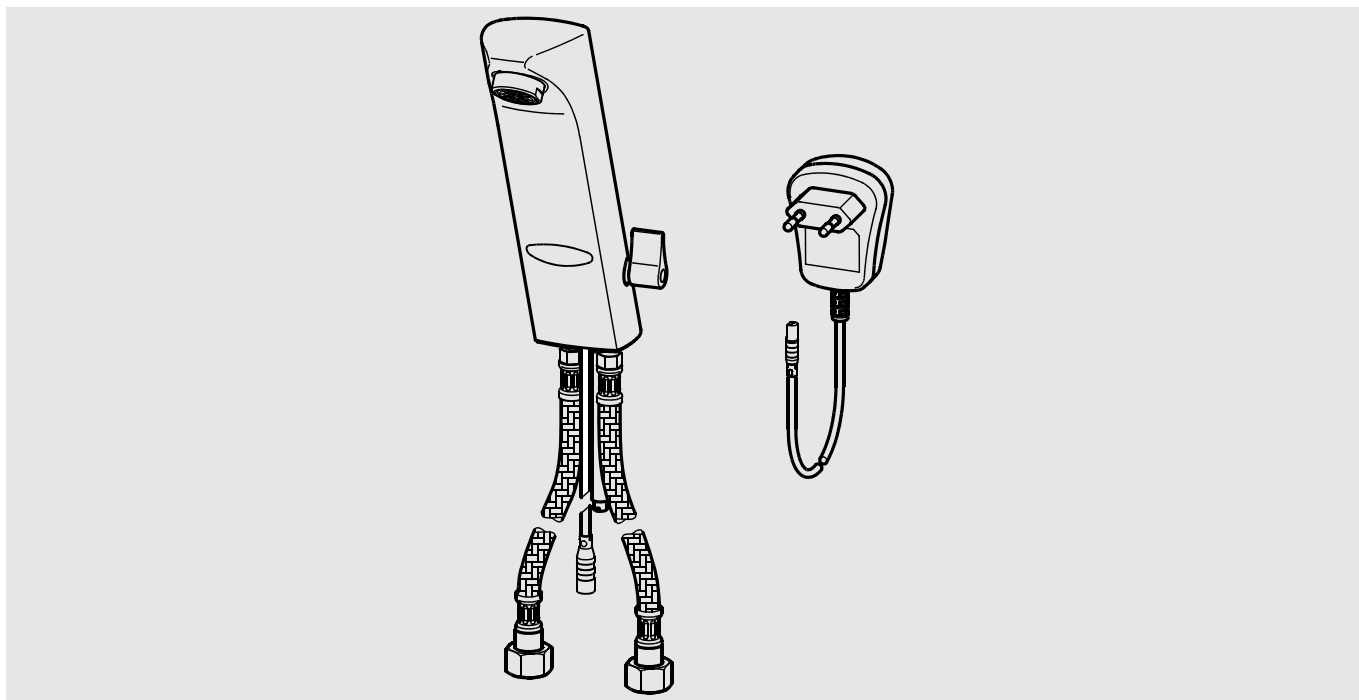
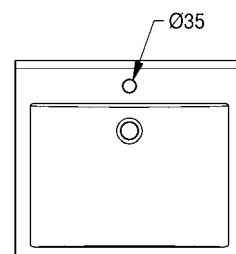
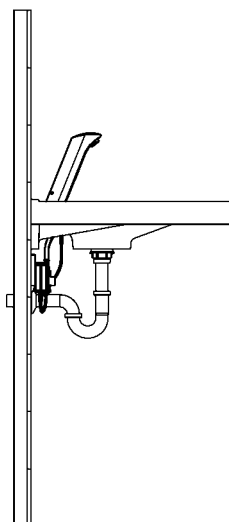
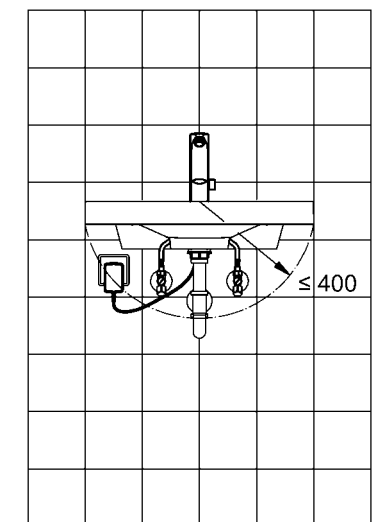

PRTRS0009
2030025078

EN	Installation and operating instructions	Electronic washbasin mixer
DE	Montage- und Betriebsanleitung	Elektronik-Waschtischmischer
FR	Notice de montage et de mise en service	Mitigeur électronique pour lavab
ES	Instrucciones de montaje y servicio	Mezclador electrónico para lavab
IT	Istruzioni per il montaggio e l'uso	Miscelatore elettronico per lava
NL	Montage- en bedrijfsinstructies	Elektronische wastafelmengkraan
PL	Instrukcja montażu i obsługi	Elektr. armatura umywalkowa
SV	Monterings- och driftinstruktion	Elektronisk blandare till tvätts
CS	Návod pro montáž a provoz	Elektronická umyvadlová směšovac
FI	Asennus- ja käyttöohje	Elektroninen allassekoittaja
RU	Инструкция по монтажу и вводу в эксплуатацию	Электронный смеситель для умывал

**EN**

Installation and operating instructions

Important notes

- ▶ Before installing flush piping system!
- ▶ After completing the installation, set the temperature limiter!
- ▶ The fitting must be operated only with original mesh filters and return flow inhibitors!

Technical data

- ▶ Minimum flow pressure 1.0 bar
- ▶ Maximum operating pressure 10 bar
- ▶ Recommended flow pressure 3 bar
- ▶ Volume flow 0.1 l/s
- ▶ Supply voltage 230 V AC
- ▶ Type of protection IP 55/IP 22
- ▶ Operating voltage 6 V DC

DE

Montage- und Betriebsanleitung

Wichtige Hinweise

- ▶ Vor Installation Rohrleitungen gemäß DIN 1988 spülen!
- ▶ Nach erfolgter Montage die Temperaturbegrenzung einstellen!
- ▶ Armatur nur mit original Sieben und Rückflussverhinderern betreiben!

Technische Daten

- ▶ Mindestfließdruck 1,0 bar
- ▶ Maximaler Betriebsdruck 10 bar
- ▶ Empfohlener Fließdruck 3 bar
- ▶ Volumenstrom 0,1 l/s
- ▶ Anschlussspannung 230 V AC
- ▶ Schutzart IP 55/IP 22
- ▶ Betriebsspannung 6 V DC

PL

Instrukcja montażu i obsługi

Ważne wskazówki

- ▶ Przed instalacją przepłukać rury!
- ▶ Po zakończeniu montażu ustawić ograniczenie temperatury!
- ▶ Armatury należy używać wyłącznie z oryginalnymi sitkami i zaworami zwrotnymi!

Dane techniczne

- ▶ Minimalne ciśnienie przepływu 1,0 bar
- ▶ Maksymalne ciśnienie robocze 10 barów
- ▶ Zalecane ciśnienie przepływu 3 barów
- ▶ Objętościowe natężenie przepływu 0,1 l/s
- ▶ Rodzaj ochrony 230 V AC
- ▶ Rodzaj ochrony IP 55/IP 22
- ▶ Napięcie robocz 6 V DC

FR

Notice de montage et de mise en service

Remarques importantes

- ▶ Rincer les conduites avant d'installer !
- ▶ Une fois le montage terminé, régler la limitation de température !
- ▶ Ne faire fonctionner la robinetterie qu'avec les filtres et clapets de non retour d'origine !

Données techniques

- ▶ Pression dynamique minimale 1,0 bar
- ▶ Pression de service maximale 10 bars
- ▶ Pression dynamique recommandée 3 bars
- ▶ Débit volumique 0,1 l/s
- ▶ Tension de raccordement 230 V AC
- ▶ Type de protection IP 55/IP 22
- ▶ Tension de service 6 V DC

SV

Monterings- och driftinstruktion

Viktiga informationer

- ▶ Spola igenom rörledningarna före installation!
- ▶ När monteringen har gjorts skall temperaturbegränsningen ställas in!
- ▶ Använd armaturen endast med originalsilar och originalåterflödesförhindrare!

Tekniska data

- ▶ Minsta hydrauliska tryck 1,0 bar
- ▶ Maximalt drifttryck 10 bar
- ▶ Rekommenderat hydrauliskt tryck 3 bar
- ▶ Volymström 0,1 l/s
- ▶ Skyddsklass 230 V AC
- ▶ Skyddsklass IP 55/IP 22
- ▶ Driftspänning 6 V DC

CS

Návod pro montáž a provoz

Důležité pokyny

- ▶ Před instalací potrubí propláchněte!
- ▶ Po provedené montáži nastavit omezení teploty!
- ▶ Provozovat armaturu jen s originálními sítky a zařízeními proti zpětnému toku!

Technické údaje

- ▶ Minimální průtočný tlak 1,0 bar
- ▶ Maximální provozní tlak 10 bar
- ▶ Doporučený průtočný tlak 3 bar
- ▶ Průtok 0,1 l/s
- ▶ Přípojné napětí 230 V AC
- ▶ Krytí IP 55/IP 22
- ▶ Provozní napětí 6 V DC

ES

Instrucciones de montaje y servicio

Indicaciones importantes

- ▶ ¡Enjuagar las tuberías antes de instalar!
- ▶ ¡Ajuste el límite de temperatura tras realizar el montaje!
- ▶ ¡La grifería debe hacerse funcionar únicamente con los tamices y las válvulas antiretorno originales!

Datos técnicos

- ▶ Presión mínima de flujo 1,0 bar
- ▶ Presión máxima de servicio 10 bares
- ▶ Presión de flujo recomendada 3 bares
- ▶ Flujo volumétrico 0,1 l/s
- ▶ Tensión de conexión 230 V AC
- ▶ Modo de protección IP 55/IP 22
- ▶ Tensión de servicio 6 V DC

FI

Asennus- ja käyttöohje

Tärkeitä ohjeita

- ▶ Huuhtele putkijohdot ennen asennusta!
- ▶ Säädä asennuksen jälkeen lämpötilan rajoitus!
- ▶ Käytä varusteet vain alkuperäisten sihtien ja takaisinvirtauksen eston kanssa!

Tekniset tiedot

- ▶ Vähimmäisvirtauspaine 1,0 bar
- ▶ Suurin käyttöpaine 10 bar
- ▶ Suositeltava virtauspaine 3 bar
- ▶ Tilavuusvirta 0,1 l/s
- ▶ Verkköjännite 230 V AC
- ▶ Suojaustapa IP 55/IP 22
- ▶ Käyttöjännite 6 V DC

IT

Istruzioni per il montaggio e l'uso

Avvertenze importanti

- ▶ Sciacquare le tubazioni prima di installare!
- ▶ Una volta terminata l'installazione, impostare la limitazione di temperatura!
- ▶ Utilizzare la rubinetteria esclusivamente con i filtri e le valvole antiriflusso originali!

Specifiche tecniche

- ▶ Pressione idraulica min. 1,0 bar
- ▶ Pressione di esercizio max. 10 bar
- ▶ Pressione idraulica consigliata 3 bar
- ▶ Portata volumetrica 0,1 l/s
- ▶ Tensione di allacciamento 230 V AC
- ▶ Tipo di protezione IP 55/IP 22
- ▶ Tensione di esercizio 6 V DC

RU

Инструкция по монтажу и вводу в эксплуатацию

Важные указания

- ▶ Перед инсталляцией промыть трубки!
- ▶ После монтажа отрегулировать температурный предел!
- ▶ Эксплуатировать арматуру только с оригинальными фильтрами и клапанами обратного течения!

Технические характеристики

- ▶ Минимальный гидравлический напор 1,0 бар
- ▶ Максимальное рабочее давление 10 бар
- ▶ Рекомендуемый гидравлический напор 3 бар
- ▶ Объемный расход 0,1 л/с
- ▶ Напряжение питающей сети 230 В переменного тока
- ▶ Вид защиты IP 55/IP 22
- ▶ рабочее напряжение 6 В постоянного тока

Belangrijke aanwijzingen

- ▶ Voor installatie buisleidingen spoelen!
- ▶ Na de montage de temperatuurbegrenzing instellen!
- ▶ Armatuur alleen met originele zeven en terugstroomkleppen gebruiken!

Technische gegevens

- ▶ Minimale dynamische druk 1,0 bar
- ▶ Maximale werkdruk 10 bar
- ▶ Aanbevolen dynamische druk 3 bar
- ▶ Volumestroom 0,1 l/s
- ▶ Aansluitspanning 230 V AC
- ▶ Veiligheidsgraad IP 55/IP 22
- ▶ Bedrijfsspanning 6 V DC

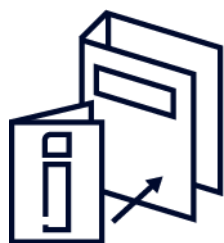

1. Montage

EN Installation
FR Montage
ES Montaje
IT Montaggio

NL Montage
PL Montaż
SV Montering

CS Montáž
FI Asennus
RU Монтаж



13 mm

19 mm

1

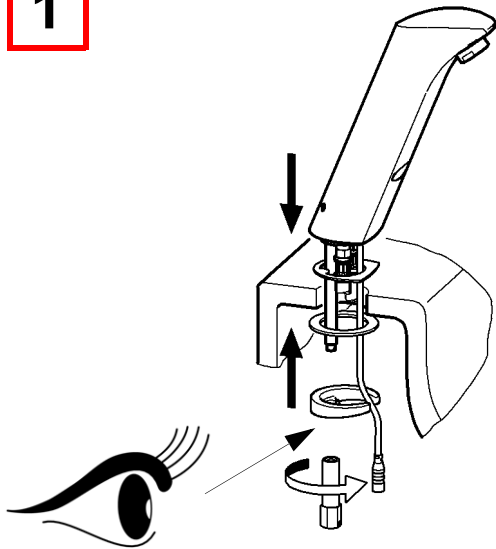

on top

2

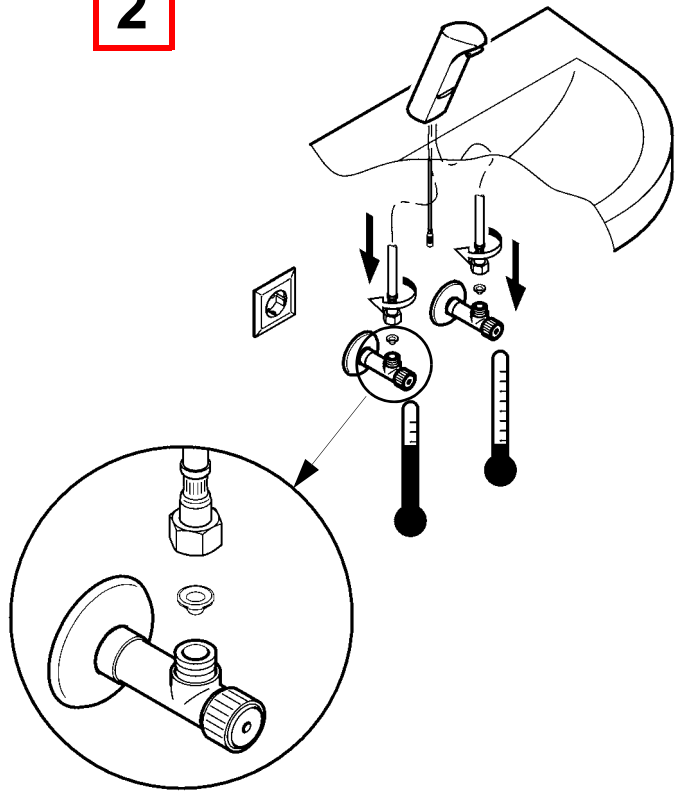

3

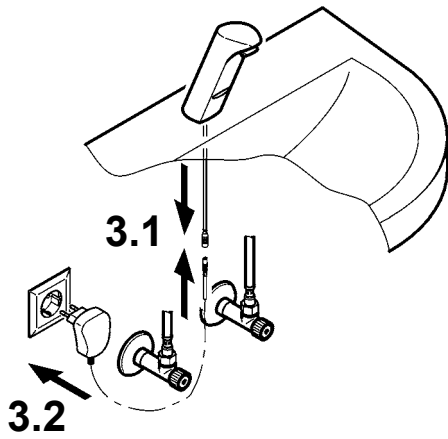

4

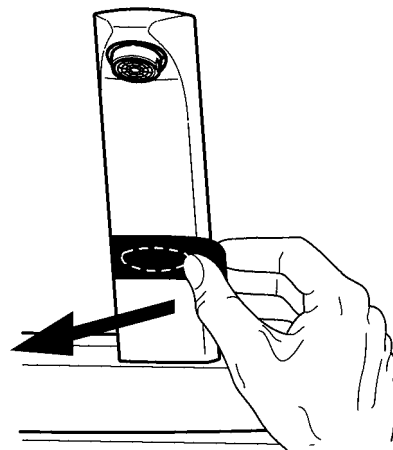

2. Funktion

EN Function
FR Fonctionnement
ES Función
IT Funzionamento

NL Werking
PL Funkcja
SV Funktion

CS Funkce
FI Toiminto
RU Функционирование

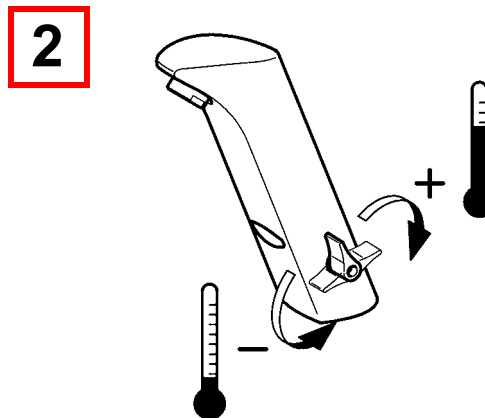
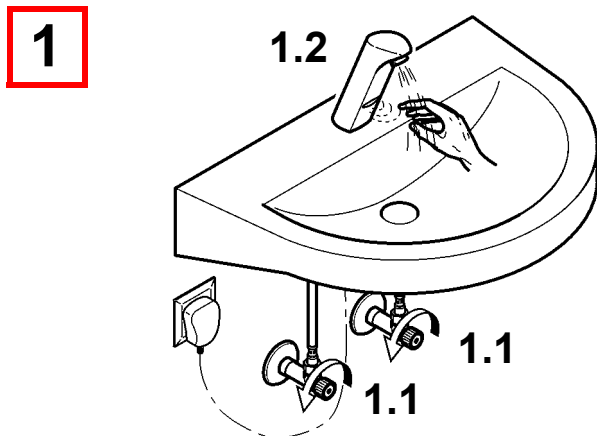

3. Mischeinrichtung verdecken

EN Conceal mixed-water facility
FR Dispositif mélangeur
ES Cubrir el elemento mezclador
IT Coprire il blocco di miscelazione

NL Menginrichting verbergen
PL Zakryć urządzenie mieszające
SV Dölj blandingsanordning

CS Zakrýt míchací zařízení
FI Peitän miksauslaitte
RU Закрывать смеситель так, чтобы его не было видно

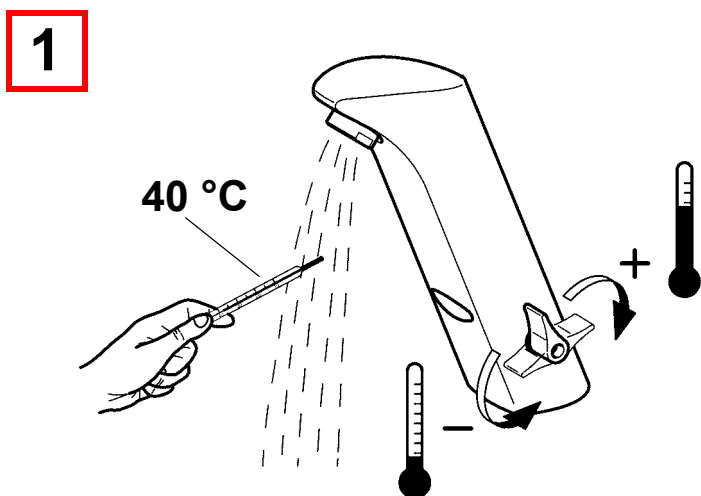
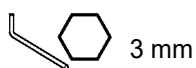

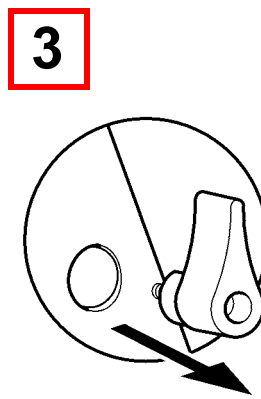
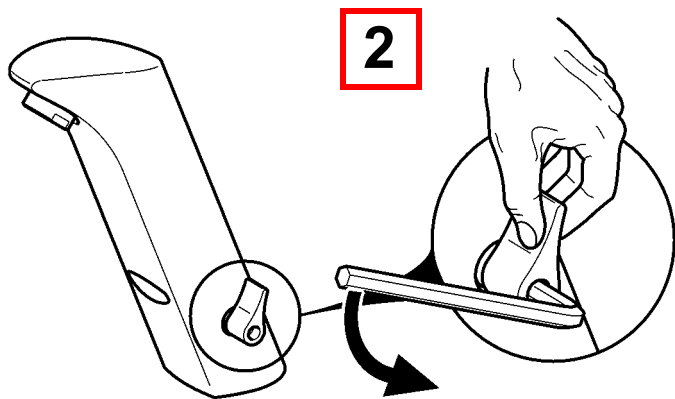

4



1

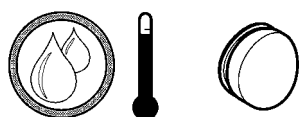

2

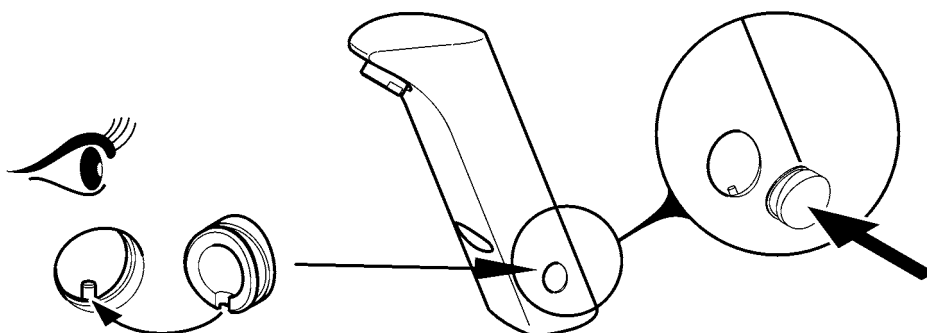
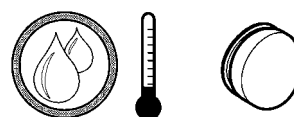

EN 1 Red
2 Blue

ES 1 Rojo
2 Azul

PL 1 Czerwony
2 Niebieski

FI 1 Punainen
2 Sininen

DE 1 Rot
2 Blau

IT 1 Rosso
2 Blu

SV 1 Röd
2 Blå

RU 1 красный
2 голубой

FR 1 Rouge
2 Bleu

NL 1 Rood
2 Blauw

CS 1 Červený
2 Modrý

4. Temperaturbegrenzung einstellen

EN Set the temperature limiter

NL Temperatuurbegrenzing instellen

CS Nastavit omezení teploty

FR Régler la limitation de température

PL Ustawiać ograniczenie temperatury

FI Säädä lämpötilan rajoitus

ES Ajuste el límite de temperatura

SV Ställ in temperaturbegränsningen

RU установить ограничение по температуре

IT Impostare la limitazione di temperatura

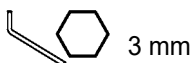

1

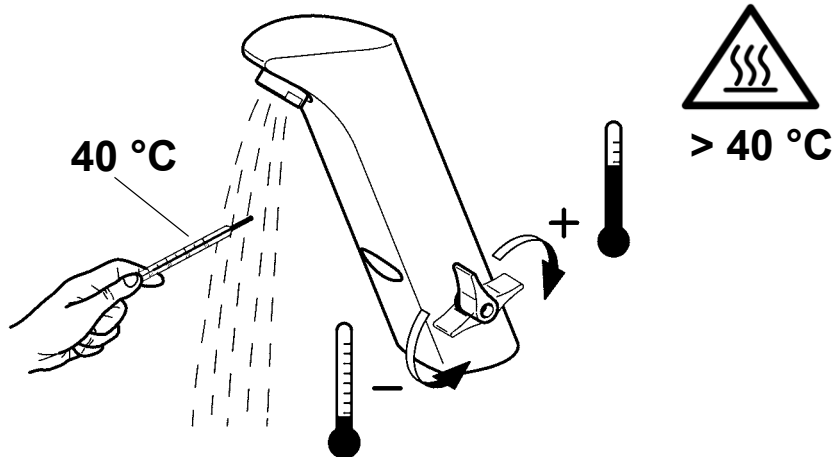

2

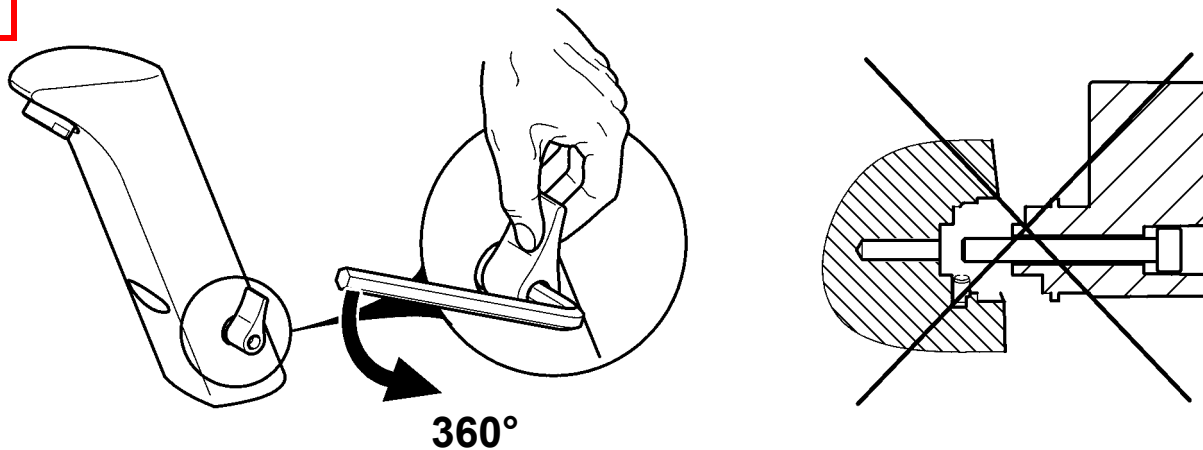

3

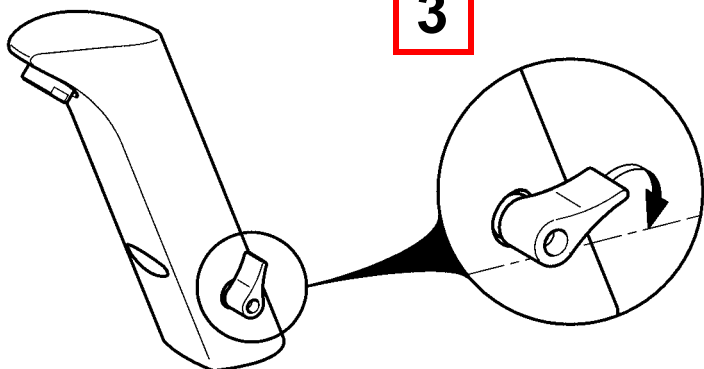

4

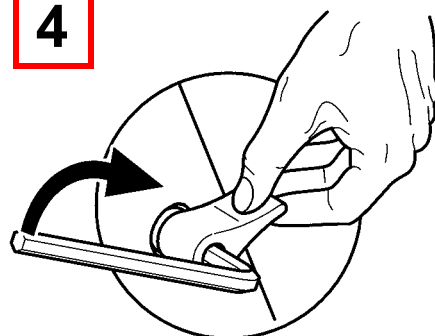

5. Anzeige: Status Hygienespülung

EN Display:
Status hygiene flushing

FR Affichage :
état rinçage hygiénique

ES Indicación:
estado del enjuague de higiene

IT Indicazione:
stato sciacquo igienico

NL Aanduiding:
Status hygiënespoeling

PL Wyświetlacz: status spłuki-
wania higienicznego

SV Indikering:
Status hygiensköljning

CS Indikátor:
stav hygienického omytí

FI Näyttö:
hygieniahuuhtelun tilanne

RU Индикатор:
состояние гигиенической мойки

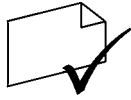

1

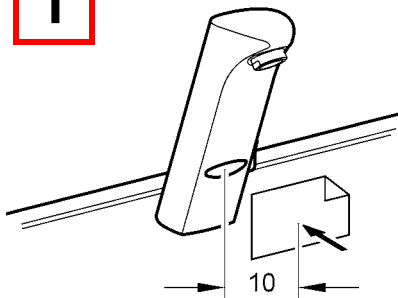

2

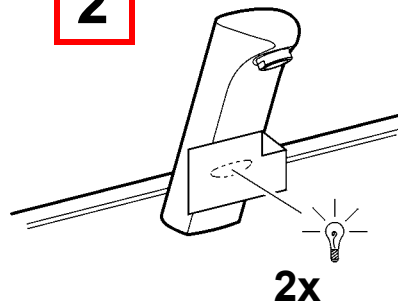

3

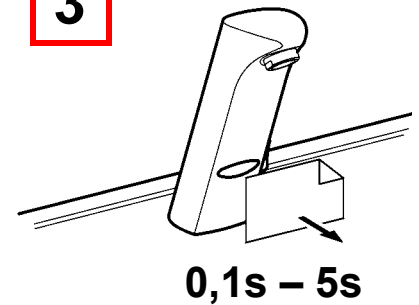

on

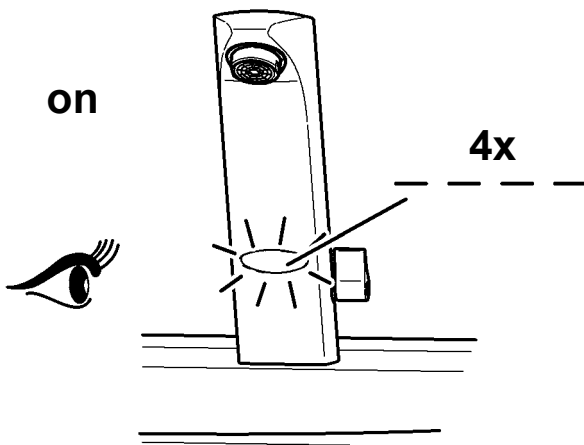

off

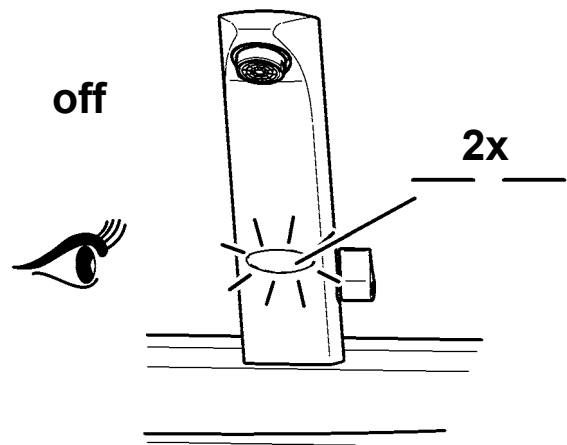

6. Hygienspülung ein- / ausschalten

EN Switching hygiene flushing on/off

FR Activer/désactiver le rinçage hygiénique

ES Activar/Desactivar el aclarado higiénico

IT Attivare/disattivare lo sciacquo igienico

NL Hygiënische spoeling in-/uitschakelen

PL Włączyć/wyłączyć spłukiwanie higieniczne

SV Koppla hygienspolningen till / från

CS Zapněte/vypněte hygienické propláchnutí

FI Hygieniahuuhdelun päälle-/ pois päältä kytkeminen

RU Гигиеническое промывание включить/выключить

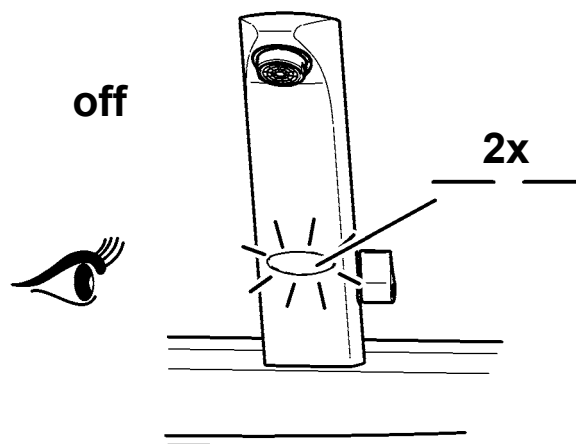
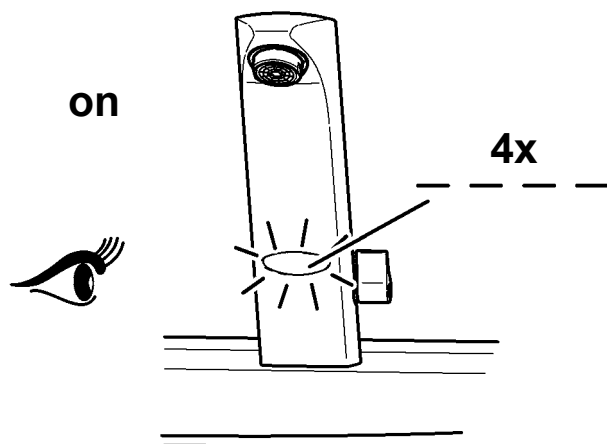
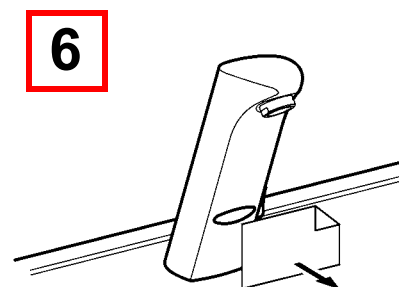
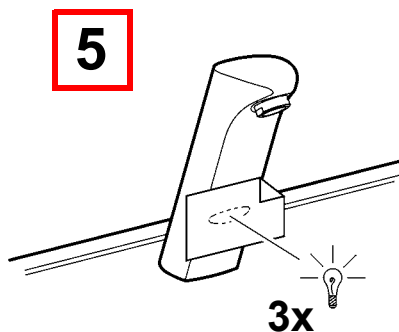
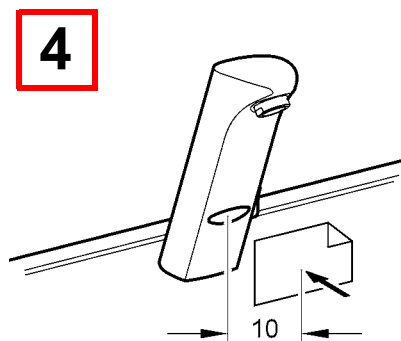
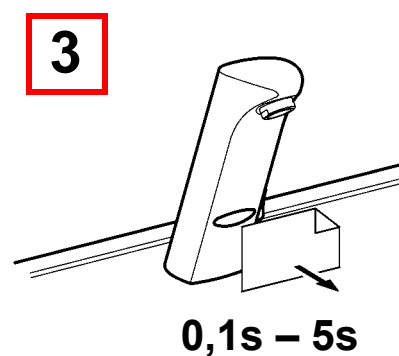
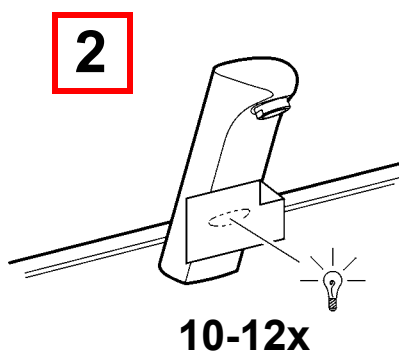
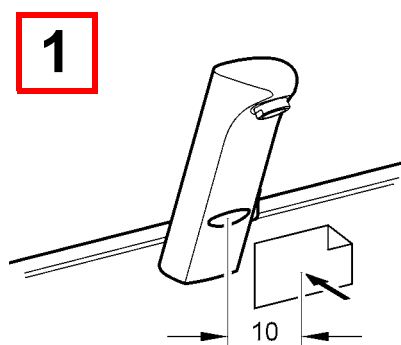
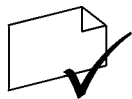

EN

- ▶ Ensure open outlet.
- ▶ After 24h of non-use, water flows 10 sec.

DE

- ▶ Freien Auslauf gewährleisten.
- ▶ Nach 24h Nichtbenutzung fließt 10 sec Wasser.

FR

- ▶ Garantir un écoulement libre.
- ▶ L'eau s'écoule pendant 10 sec. après 24h de non utilisation.

ES

- ▶ Garantizar una salida libre.
- ▶ Si no se realiza ningún uso durante 24 horas, fluye agua durante 10 segundos.

IT

- ▶ Garantire l'erogazione libera.
- ▶ Dopo 24h di inutilizzo scorre acqua per 10 sec.

NL

- ▶ Vrije uitloop garanderen.
- ▶ Na 24 uur niet te zijn gebruikt stroomt er gedurende 10 sec. water.

PL

- ▶ Zapewnić swobodny wylot.
- ▶ Po 24 godz. niekorzystania przez 10 s. wypływa woda.

SV

- ▶ Garantera fritt avlopp.
- ▶ Vatten flyter 10 sek efter 24 timmars användningspaus.

CS

- ▶ Zajistěte volný odtok.
- ▶ Při nepoužívání 24 h nechte 10 s téct vodu.

FI

- ▶ Vapaan virtauksen takaaminen.
- ▶ Käyttämättömänä 24 h jälkeen virtaa vettä 10 s.

RU

- ▶ Обеспечить беспрепятственный слив
- ▶ После того, как устройство не используется в течение 24 ч, в течение 10 сек течёт вода.

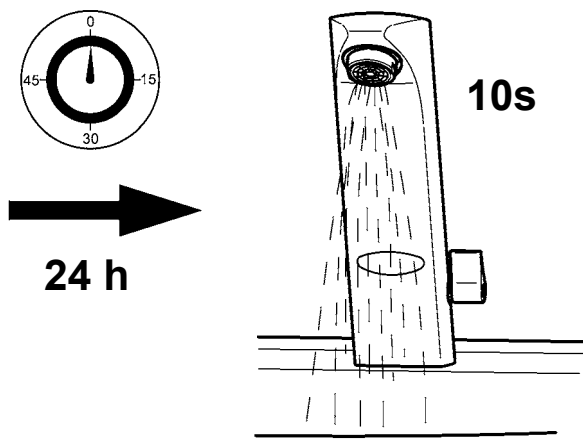

7. Armatur ausschalten

EN Switch off the valve

FR Désactiver la robinetterie

ES Desconectar la grifería

IT Disattivazione della rubinetteria

NL Armatuur uitschakelen

PL Wyłączenie baterii

SV Avstängning av armatur

CS Vypnout armaturu

FI Laitteen kytkeminen pois päältä

RU отключить оборудование

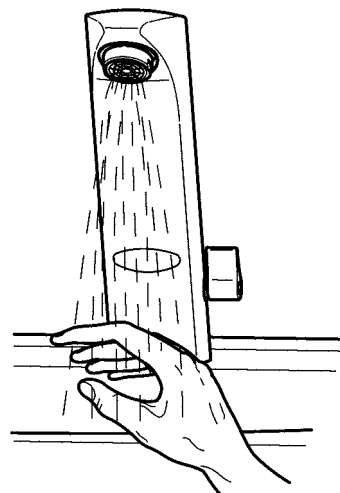
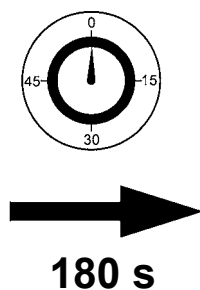
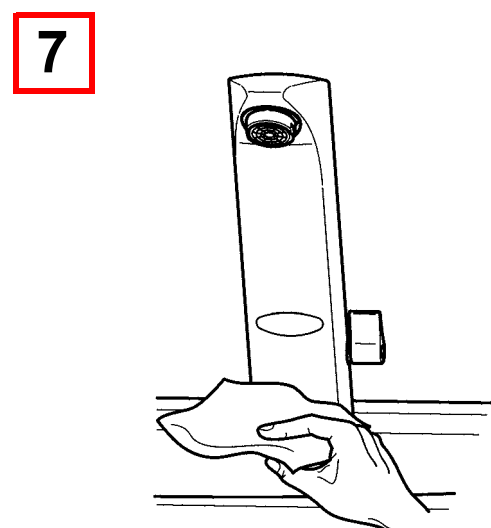
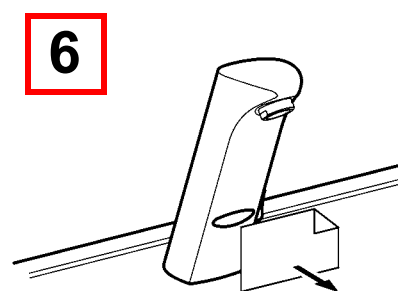
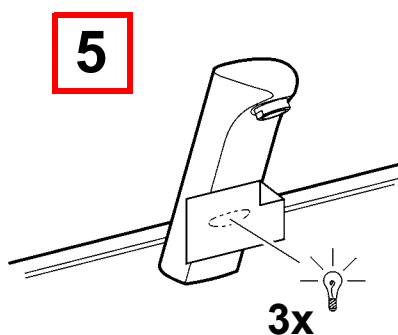
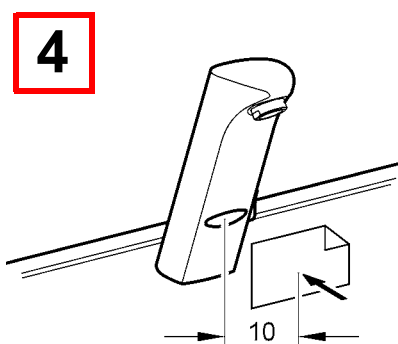
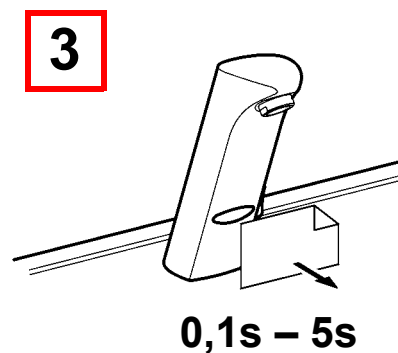
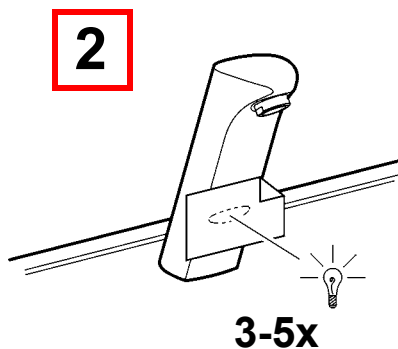
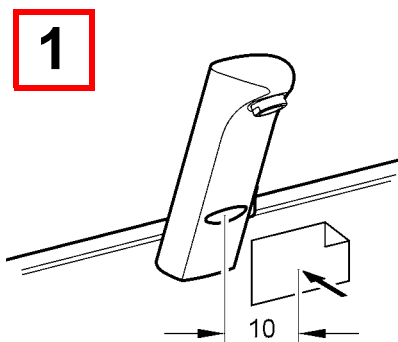
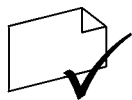

8. Dauerlauf starten

EN Start continual flow

NL Continue stroming starten

CS Spustit trvalý provoz

FR Démarrer la marche continue

PL Uruchomić stały wypływ wody

FI Tuotantokäytön aloittaminen

ES Iniciar el enjuague continuo

SV Starta kontinuerlig drift

RU запустить ресурс

IT Avviare l'erogazione continua

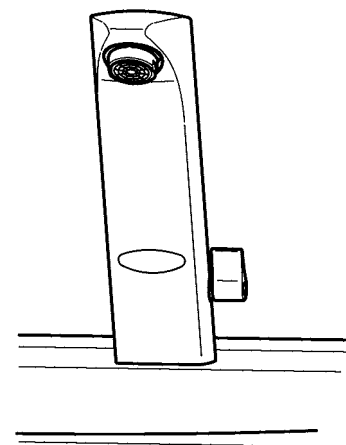
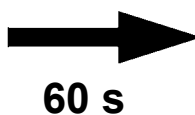
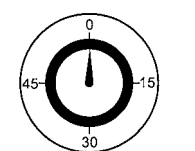
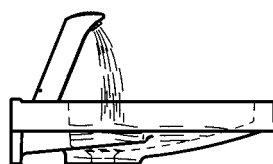
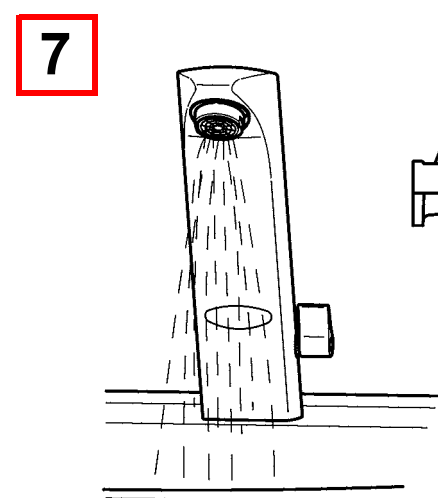
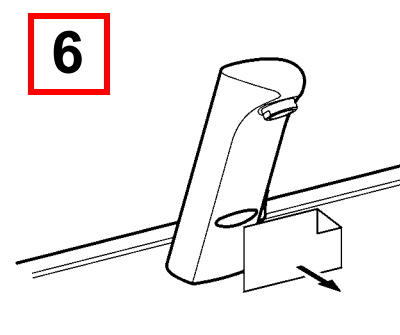
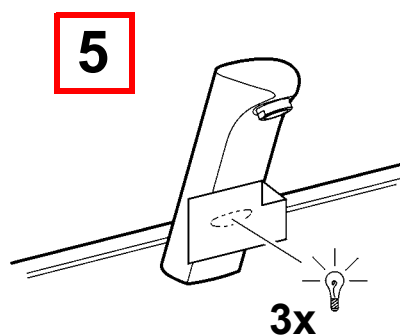
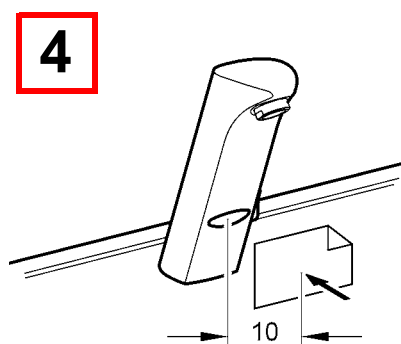
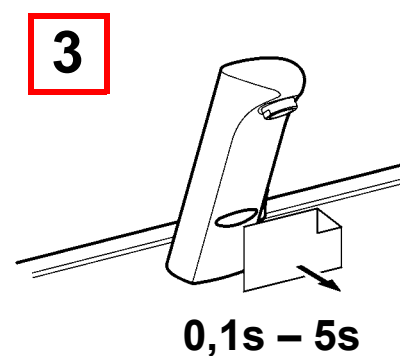
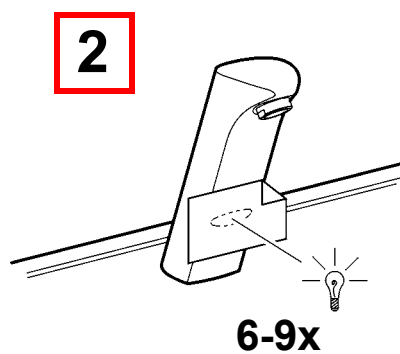
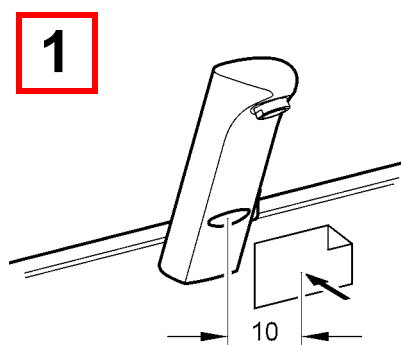
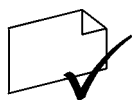

9. Anzeige: letzter Spülvorgang in Stunden

EN Display: Last flush-process in hours	NL Weergave: laatste spoelprocedure in uren	CS Upozornění: poslední vypláchnutí v hodinách
FR Affichage: dernière opération de rinçage en heures	PL Informacja: ostatnie splukiwanie w godzinach	FI Näyttö: viimeisin huuhtelutapahtuma tunteina
ES Indicación: último proceso de aclarado en hora	SV Indikering: Sista sköljning i timmar	RU На дисплее: последний смывнойой процесс в часах
IT Indicazione: ultimo sciacquo in ore		

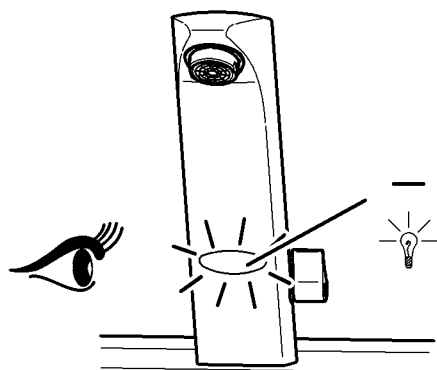
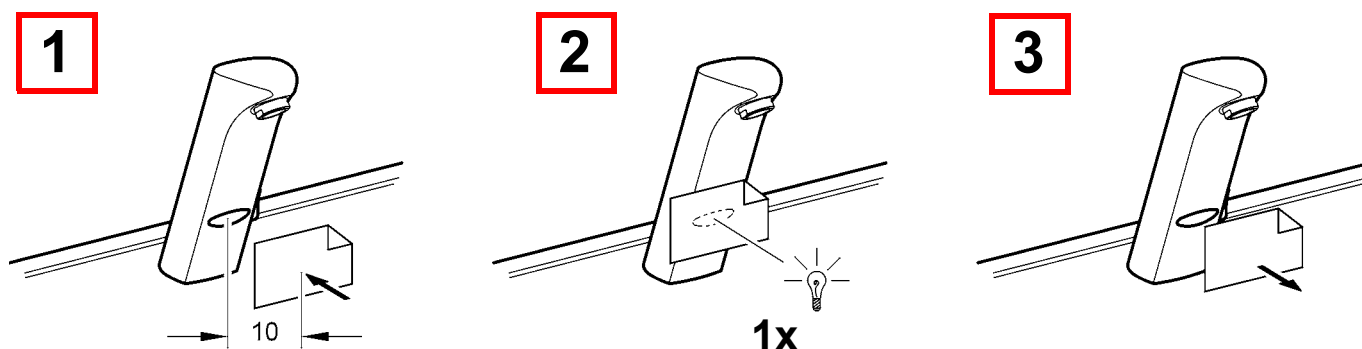

$$\begin{array}{r}
 3x = \\
 30 \text{ h} \\
 \hline
 1x = 10 \text{ h} \\
 2x = 20 \text{ h} \\
 3x = 30 \text{ h} \\
 \dots \\
 9x = 90 \text{ h}
 \end{array}
 +
 \begin{array}{r}
 4x = \\
 4 \text{ h} \\
 \hline
 1x = 1 \text{ h} \\
 2x = 2 \text{ h} \\
 3x = 3 \text{ h} \\
 \dots \\
 9x = 9 \text{ h}
 \end{array}
 = 34 \text{ h}$$

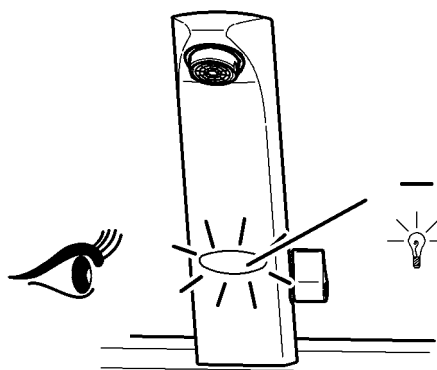

$$\begin{array}{r}
 \cancel{1x} = \\
 00 \text{ h} \\
 \hline
 0x = \\
 00 \text{ h}
 \end{array}
 +
 \begin{array}{r}
 \cancel{1x} = \\
 00 \text{ h} \\
 \hline
 0x = \\
 00 \text{ h}
 \end{array}
 = < 59 \text{ min}$$

10. Erfassungsart ändern

EN Change type of detection	NL Registratiesoort wijzigen	CS Změnit způsob snímání
FR Modifier le type de détection	PL Zmiana rodzaju wykrywania	FI Mittaustyyppin muuttaminen
ES Modificar el tipo de captación	SV Registreringsätt	RU Способ считывания
IT Modificare il tipo di rilevamento		

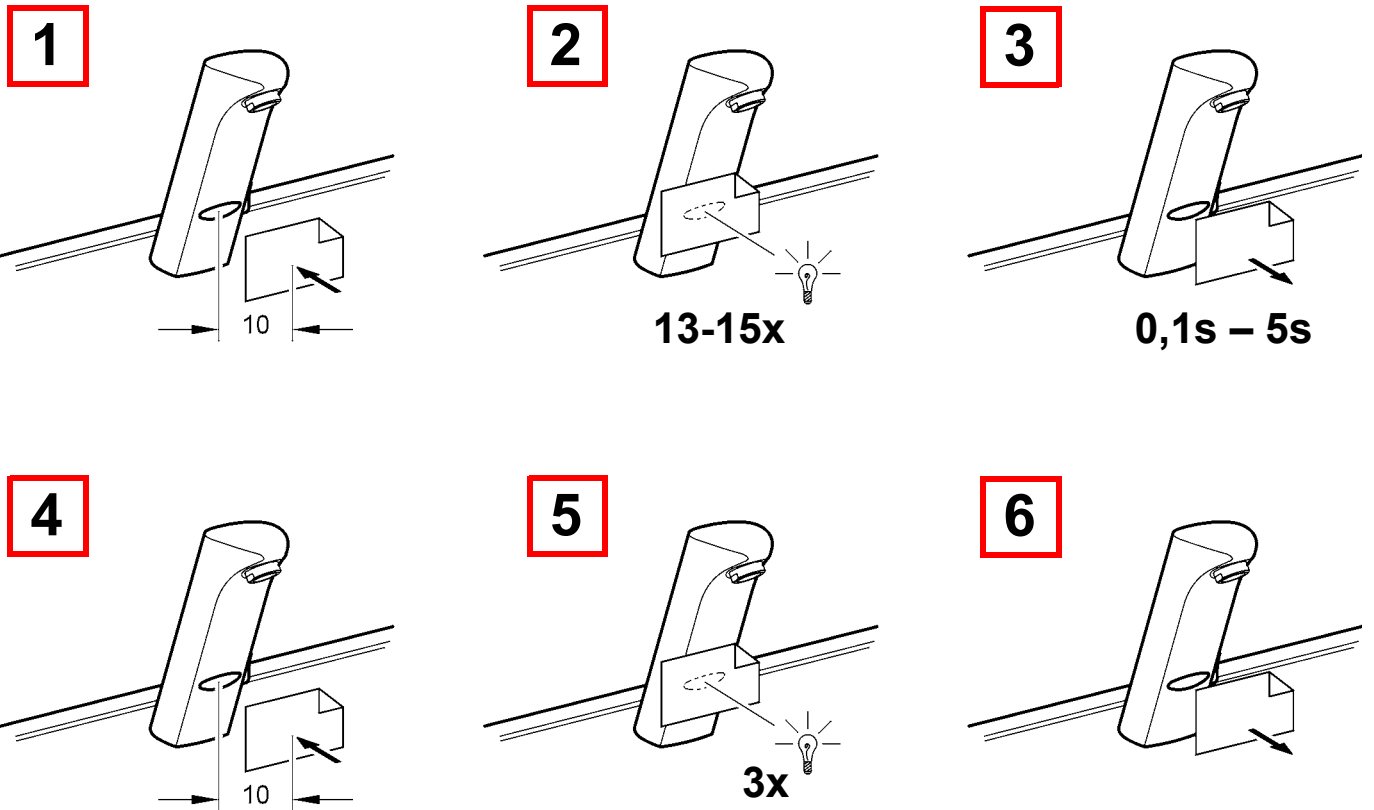

EN	Type of detection	The sensor is detecting
	A static	Object
	B dynamic	Movement (with intense reflections from basin)

DE	Erfassungsart	Der Sensor erfasst
	A statisch	Objekt
	B dynamisch	Bewegung (bei hoher Beckenreflexion)

PL	Rodzaj wykrywania	Czujnik rejestruje
	A statisch	Obiekt
	B dynamicznie	Ruch (przy dużym odbiciu fali od umywalki)

SV	Registreringsätt	Sensor registrerar
	A statisk	Objekt
	B dynamisk	Rörelse (vid hög bäckenreflexion)

FR	Type de détection	Le capteur détecte
	A statique	Objet
	B dynamique	Mouvement par forte réflexion du bassin

CS	Způsob snímání	Snímač snímá
	A statický	Objekt
	B dynamický	Pohyb (při vysokém odrazu umyvadla)

ES	Tipo de captación	El sensor está captando
	A estático	Objeto
	B dinámico	Movimiento (en caso de elevada reflexión en el lavabo)

FI	Mittaustyyppi	Anturi mittaa
	A staattinen	Kohde
	B dynaminen	Liike (suurella allasheijastuksella)

IT	Tipo di rilevamento	Il sensore rileva
	A statico	Oggetto
	B dinamico	Movimento (in caso di alta riflessione del lavabo)

RU	Способ считывания	Датчик считывает
	A статический	Объект
	B динамический	Движение (при большом отражении умывальника)

NL	Registratiesoort	De sensor registreert
	A statisch	Object
	B dynamisch	Beweging (bij hogere reservoirreflectie)

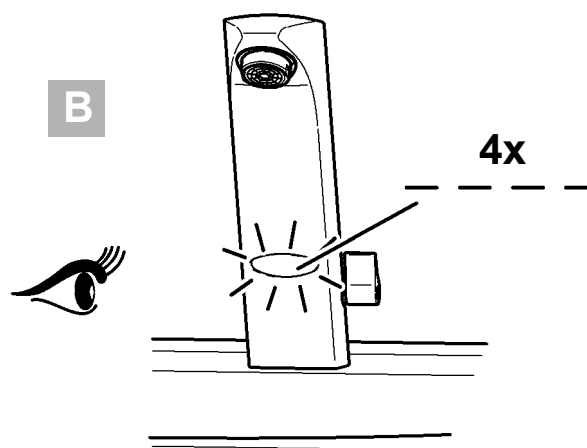
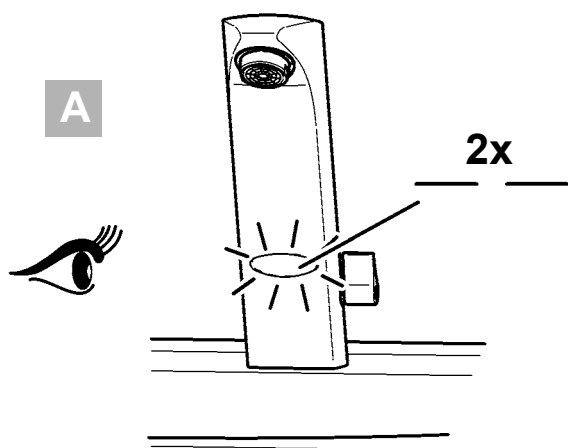

11. Wartung

EN Maintenance
 FR Maintenance
 ES Mantenimiento
 IT Manutenzione

NL Onderhoud
 PL Konserwacja
 SV Underhåll

CS Varování
 FI Huolto
 RU Техническое обслуживание



19 mm

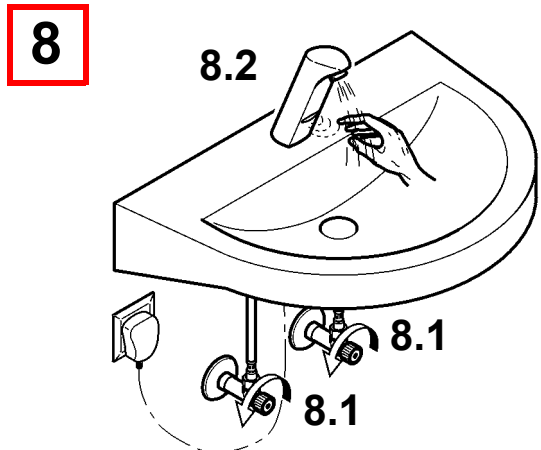
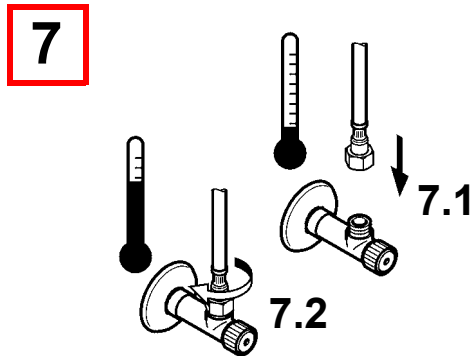
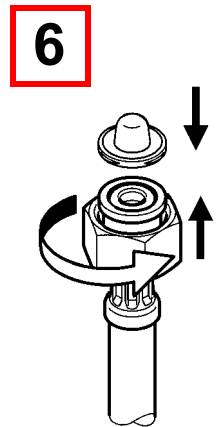
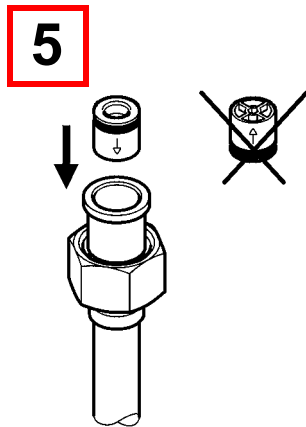
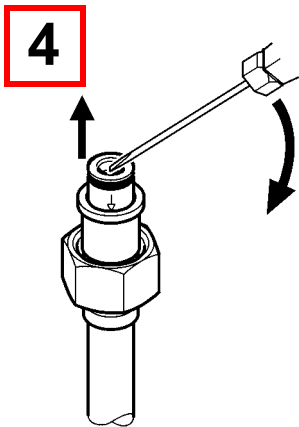
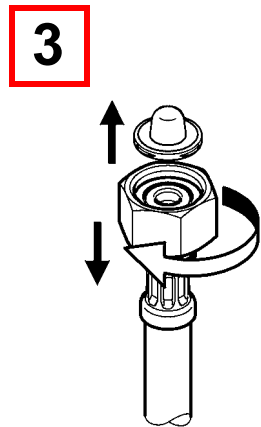
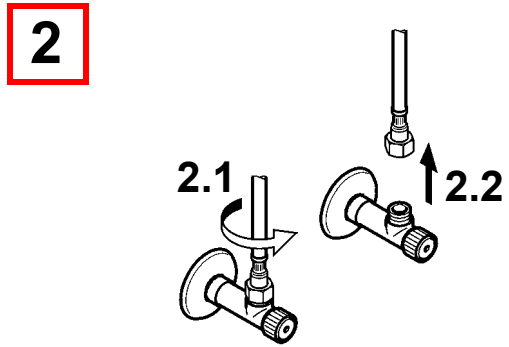
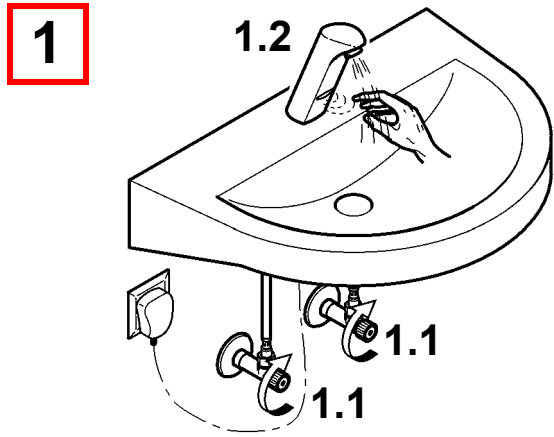



22 mm

1

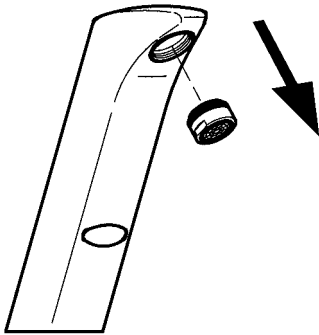

2

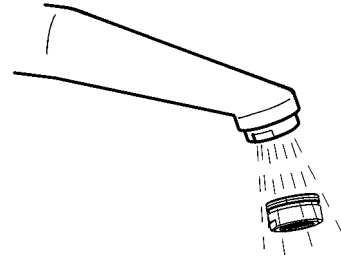

12. Funktionsteil ausbauen

EN Remove functional part

NL Functie-element demonteren

CS Demontovat funkční díl

FR Démonter l'élément fonctionnel

PL Wymontować element funkcjonalny

FI Kunnossapito

ES Desmontar la pieza funcional

SV Bygga ut funktionsdelen

RU Демонтаж функциональной детали

IT Smontaggio dell'elemento funzionale



3 mm

1

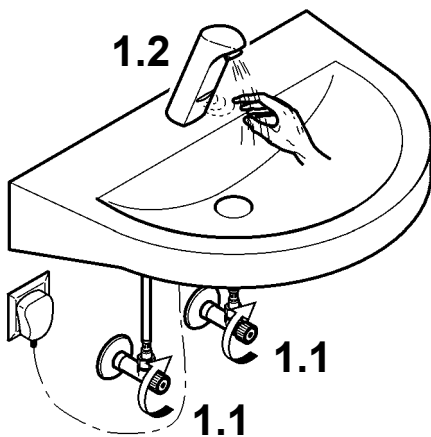

2

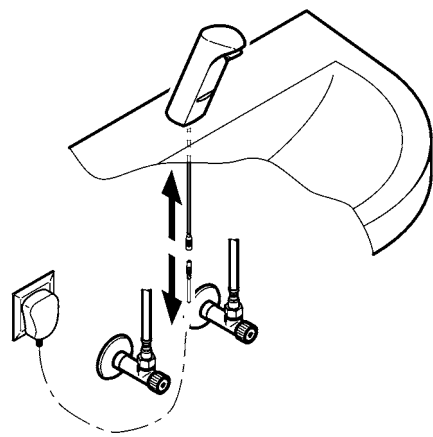

3

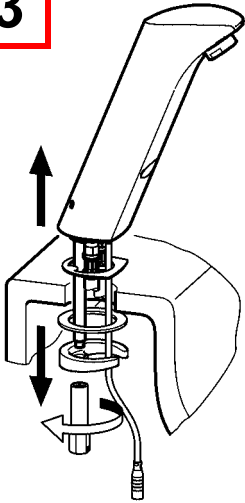

4

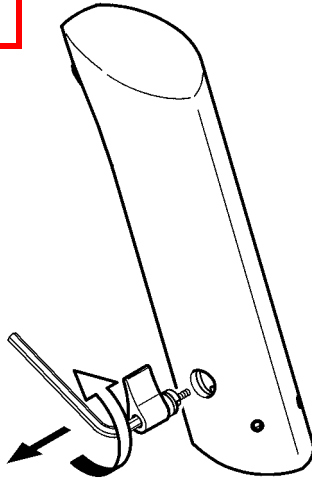

5

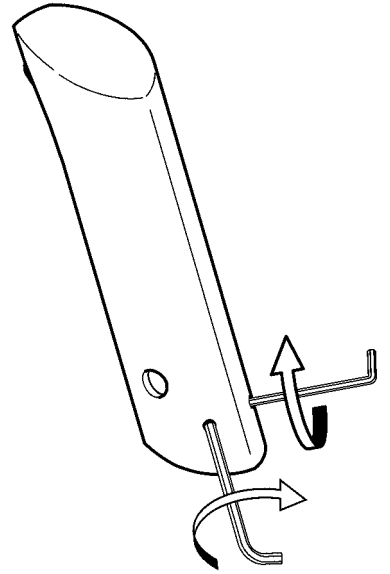

6

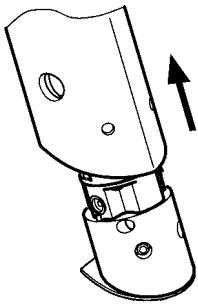

7

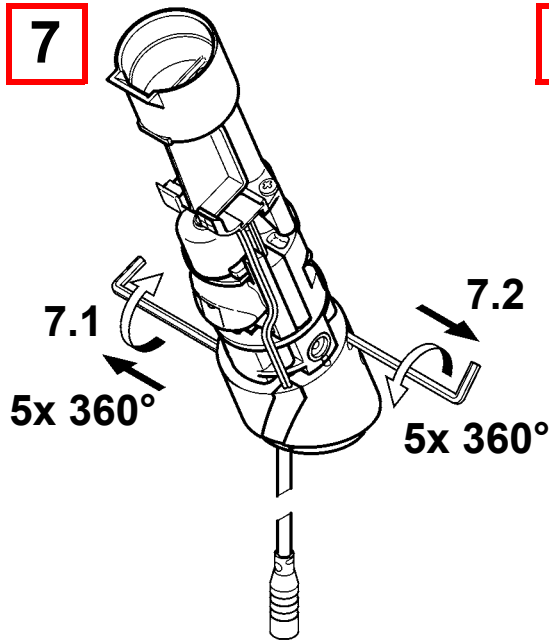

8

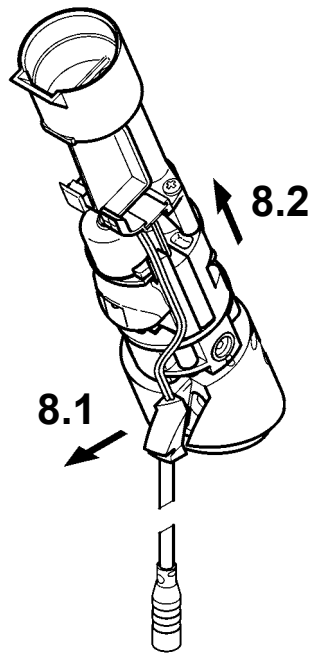

9

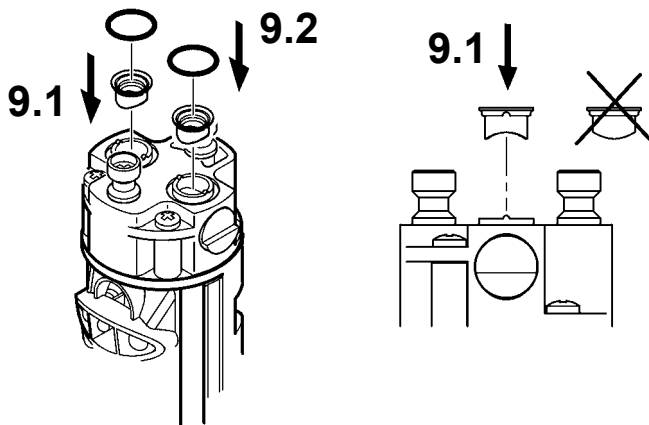

10

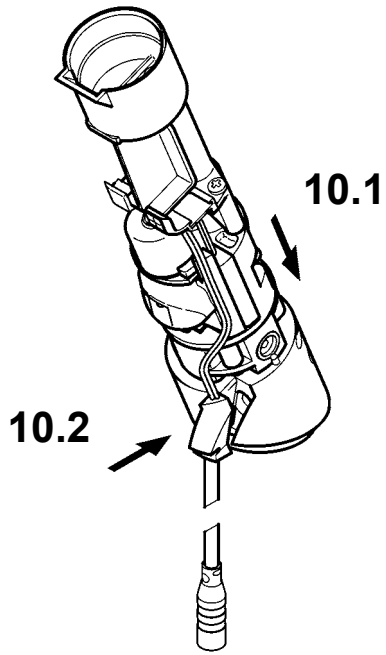

11

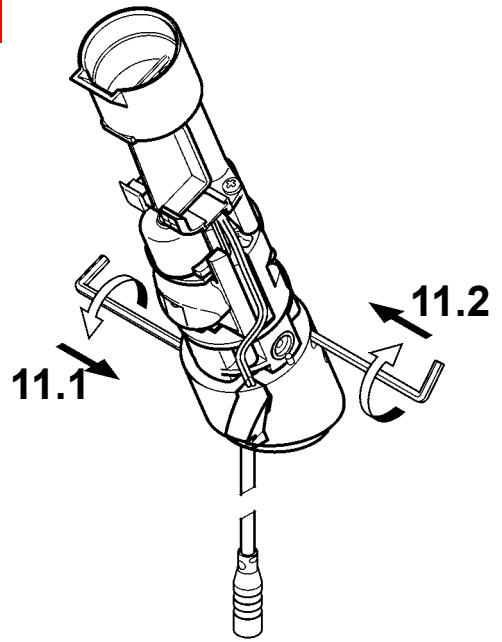

12

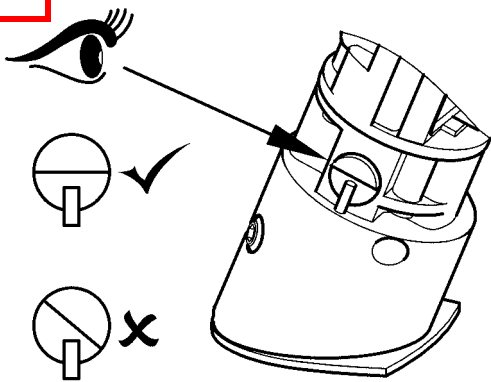

13

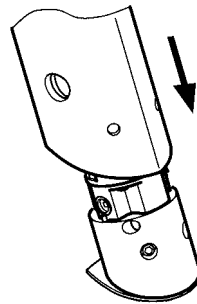

14

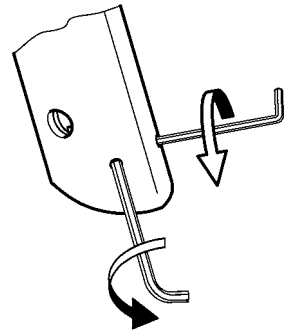

15

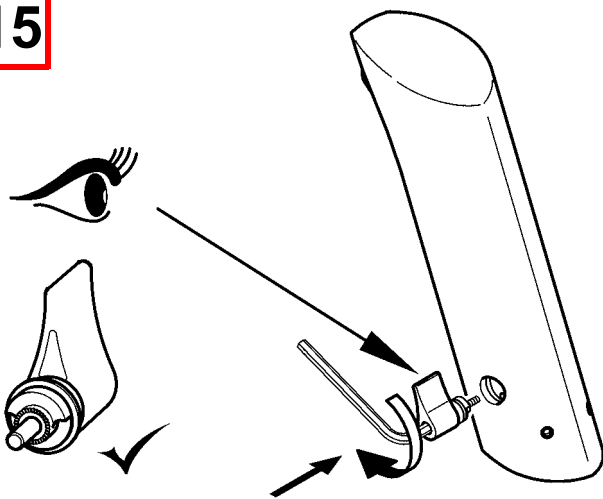

16

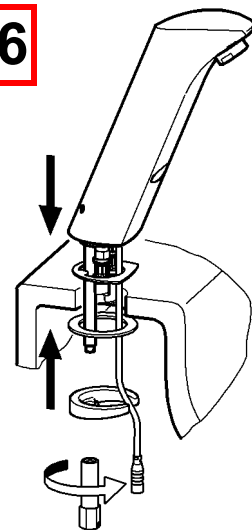

17

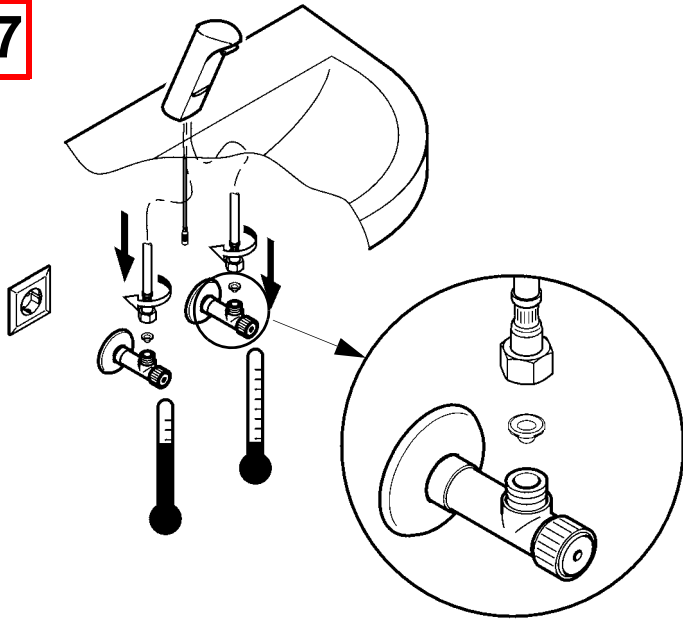

18

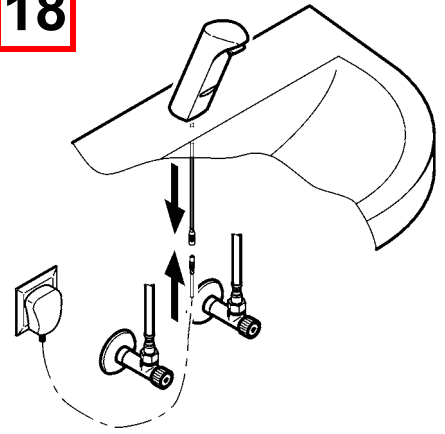

19

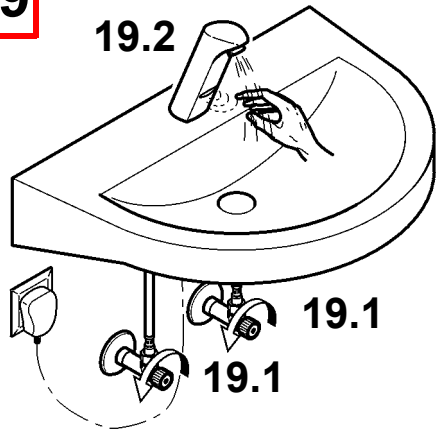

20

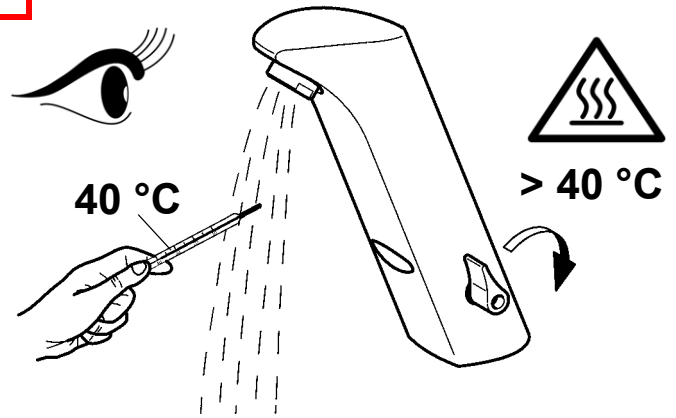

13. Ersatzteile

EN Replacement parts
FR Pièces de rechange
ES Piezas de recambio
IT Pezzi di ricambio

NL Reserveonderdelen
PL Części zamienne
SV Reservdelar

CS Náhradní díly
FI Varaosat
RU Запчасти

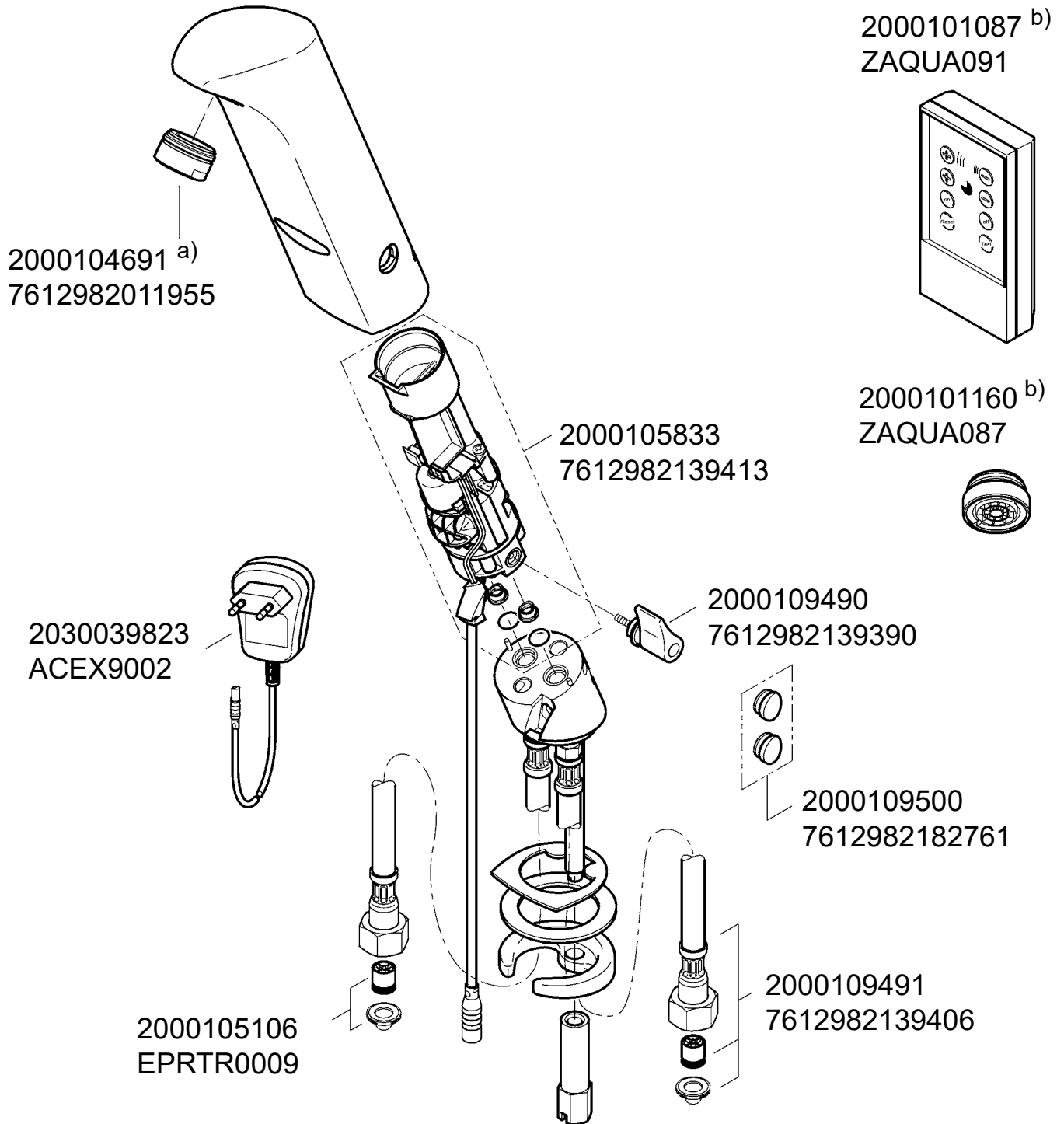

EN a) 10 pieces
b) Accessories

ES a) 10 piezas
b) Accesorios

PL a) 10 sztuk
b) Akcesoria

FI a) 10 kappaletta
b) Lisävarusteet

DE a) 10 Stück
b) Zubehör

IT a) 10 pezzi
b) Accessori

SV a) 10 styck
b) Tillbehör

RU a) 10 штук
b) принадлежности

FR a) 10 pièces
b) Accessoire

NL a) 10 stuk
b) Toebehoren

CS a) 10 kusů
b) Příslušenství

Notizen

EN Notes

FR Notes

ES Notas

IT Annotazioni

NL Notities

PL Uwagi

SV Notiser

CS Poznámky

FI Muistiinpanot

RU Примечания

Notizen

EN Notes

FR Notes

ES Notas

IT Annotazioni

NL Notities

PL Uwagi

SV Notiser

CS Poznámky

FI Muistiinpanot

RU Примечания

Notizen

EN Notes

FR Notes

ES Notas

IT Annotazioni

NL Notities

PL Uwagi

SV Notiser

CS Poznámky

FI Muistiinpanot

RU Примечания

Australia

PR Kitchen and
Water Systems Pty Ltd
Dandenong South VIC 3175
Phone +61 3 9700 9100

Austria

KWC Austria GmbH
6971 Hard, Austria
Phone +43 5574 6735 0

**Belgium, Netherlands &
Luxembourg**

KWC Aquarotter GmbH
9320 Aalst; Belgium
Phone +31 (0) 492 728 224

Czech Republic

KWC Aquarotter GmbH
14974 Ludwigsfelde, Germany
Phone +49 3378 818 309

France

KWC Austria GmbH
6971 Hard, Austria
Phone +33 800 909 216

Germany

KWC Aquarotter GmbH
14974 Ludwigsfelde
Phone +49 3378 818 0

Italy

KWC Austria GmbH
6971 Hard, Austria
Numero Verde +39 800 789 233

Middle East

KWC ME LLC Ras Al Khaimah,
United Arab Emirates
Phone +971 7 2034 700

Poland

KWC Aquarotter GmbH
14974 Ludwigsfelde, Germany
Phone +48 58 35 19 700

Spain

KWC Austria GmbH
6971 Hard, Austria
Phone +43 5574 6735 211

Switzerland & Liechtenstein

KWC Group AG
5726 Unterkulm, Switzerland
Phone +41 62 768 69 00

Turkey

KWC ME LLC Ras Al Khaimah,
United Arab Emirates
Phone +971 7 2034 700

United Kingdom

KWC DVS Ltd - Northern Office
Barlborough S43 4PZ
Phone +44 1246 450 255

KWC DVS Ltd - Southern Office
Paignton TQ4 7TW
Phone +44 1803 529 021

EAST EUROPE

Bosnia Herzegovina
Bulgaria | Croatia
Hungary | Latvia
Lithuania | Romania
Russia | Serbia | Slovakia
Slovenia | Ukraine

KWC Aquarotter GmbH
14974 Ludwigsfelde, Germany
Phone +49 3378 818 261

SCANDINAVIA & ESTONIA

Finland | Sweden | Norway
Denmark | Estonia

KWC Nordics Oy
76850 Naarajärvi, Finland
Phone +358 15 34 111

OTHER COUNTRIES

KWC Austria GmbH
6971 Hard, Austria
Phone +43 5574 6735 0

