

F3

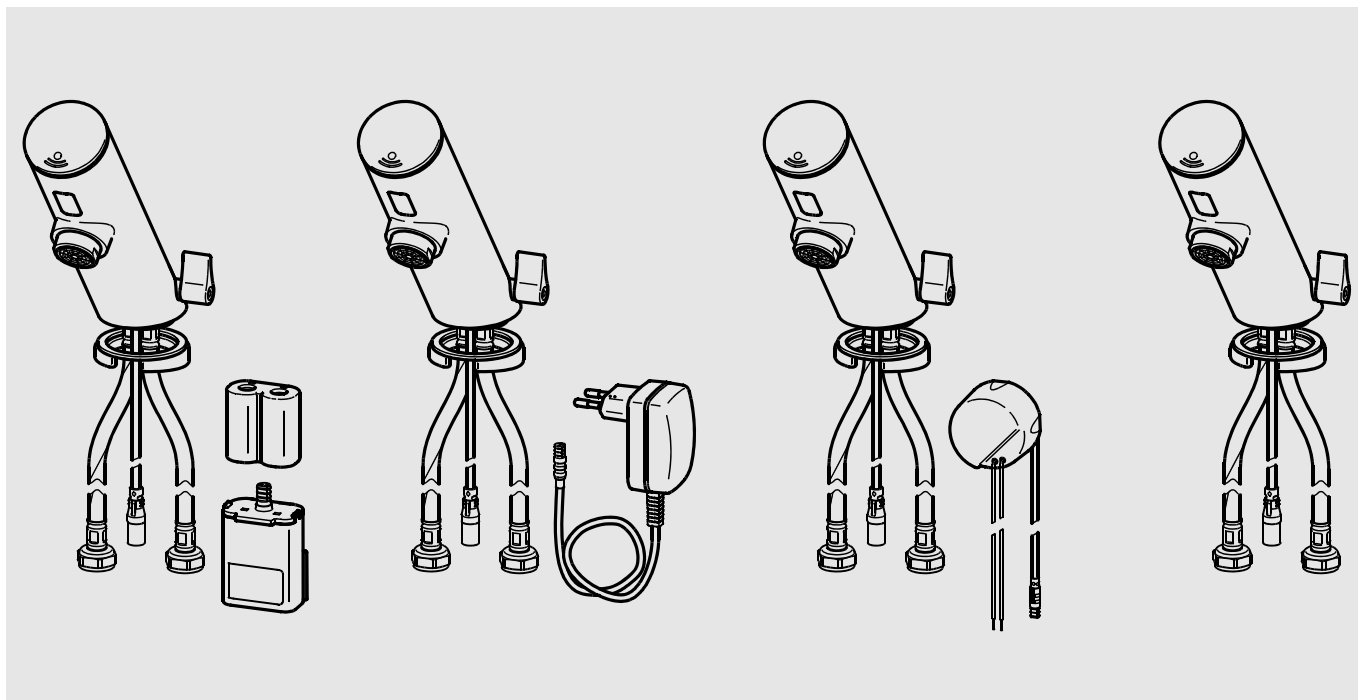

F3EM1001
2030033388

F3EM1002
2030033389

F3EM1003
2030033545

F3EM1005
2030039469

DE	Montage- und Betriebsanleitung	Elektronik-Standbatterie
EN	Installation and operating instructions	Electronic pillar mixer
FR	Notice de montage et de mise en service	Robinetterie électronique de montage sur plaque
ES	Instrucciones de montaje y servicio	Grifo de pie con sistema electrónico
IT	Istruzioni per il montaggio e l'uso	
NL	Montage- en bedrijfsinstructies	Elektronische wastafelmengkraan
PL	Instrukcja montażu i obsługi	Elektroniczna bateria ukośna
SV	Monterings- och driftinstruktion	
CS	Návod pro montáž a provoz	
FI	Asennus- ja käyttöohje	F3EM1001 Elektroninen pylväshana
RU	Инструкция по монтажу и вводу в эксплуатацию	



F3EM1001

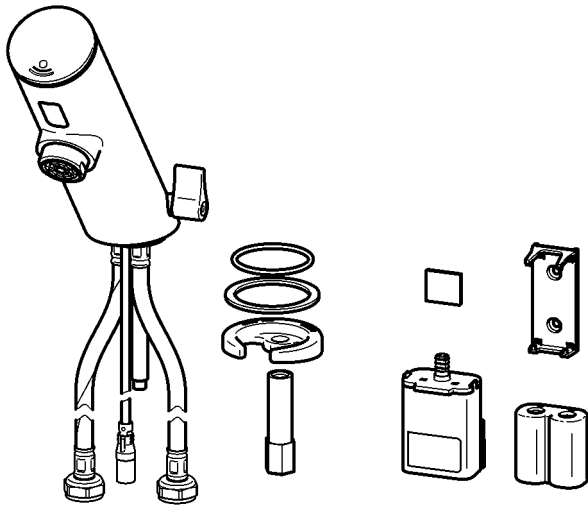

F3EM1002

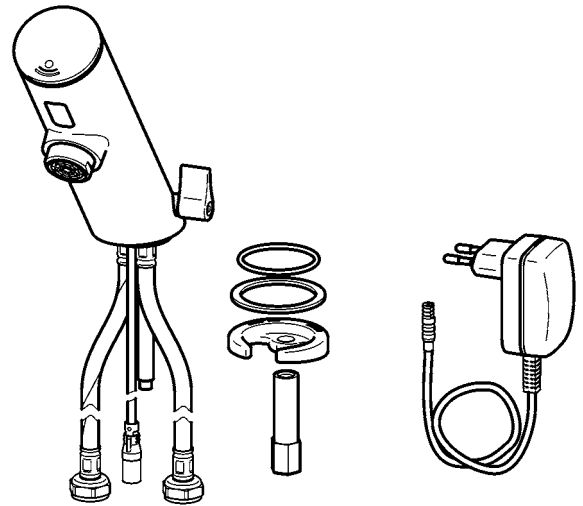

F3EM1003

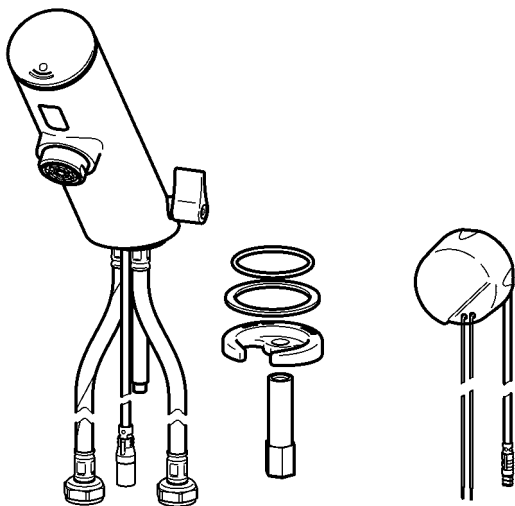

F3EM1005

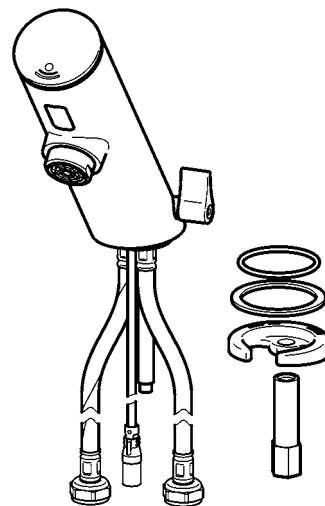

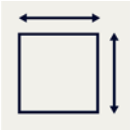

F3EM1001

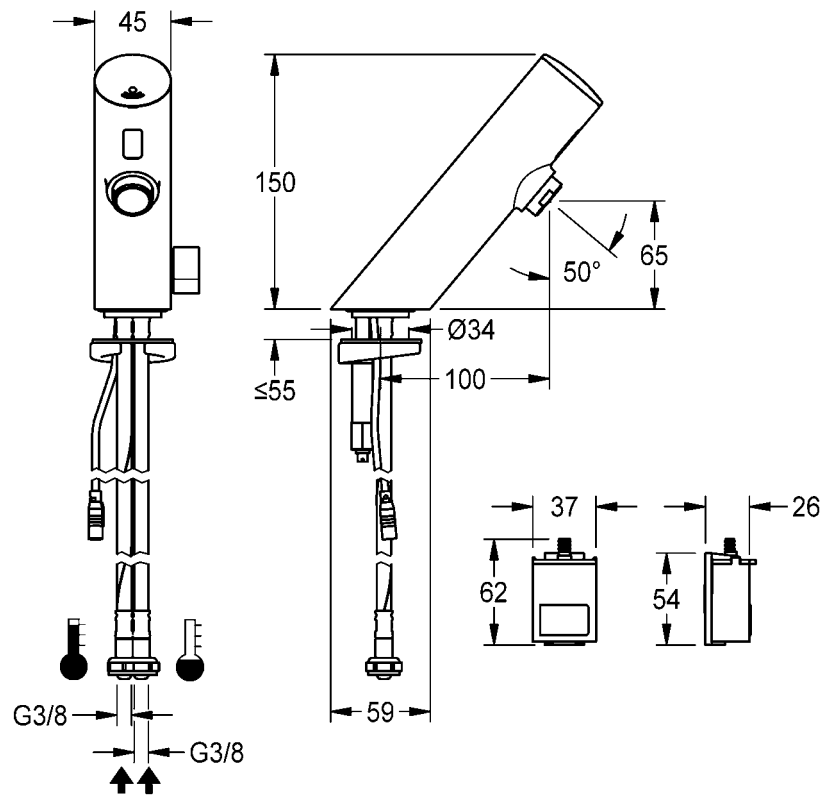

F3EM1002

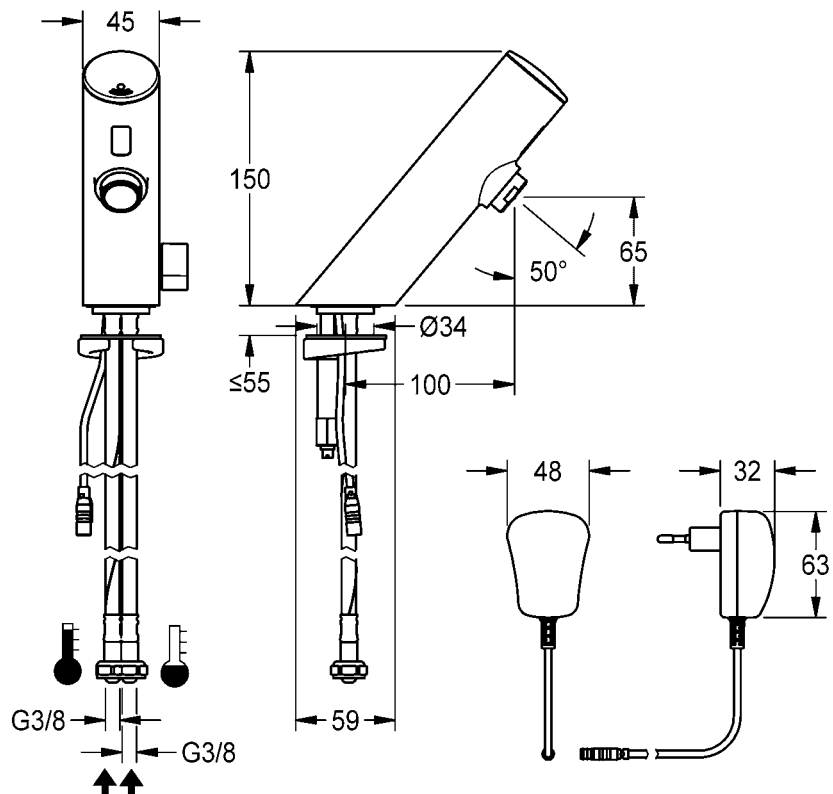

F3EM1003

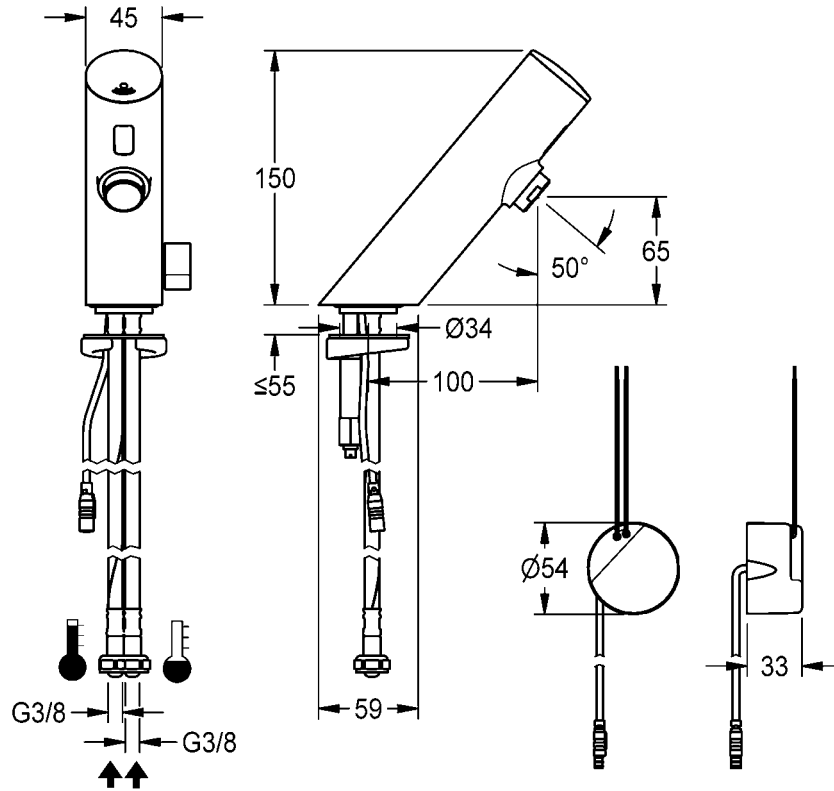

F3EM1005

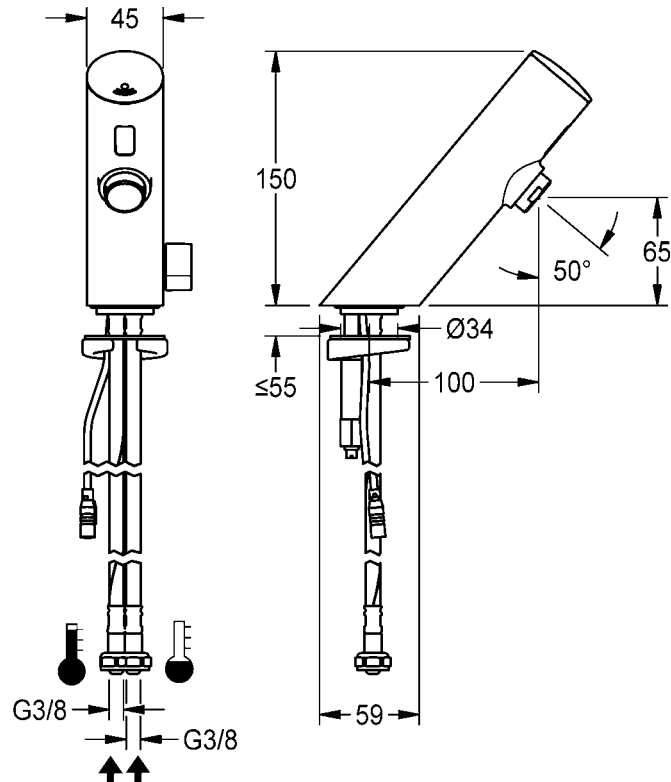



F3EM1001

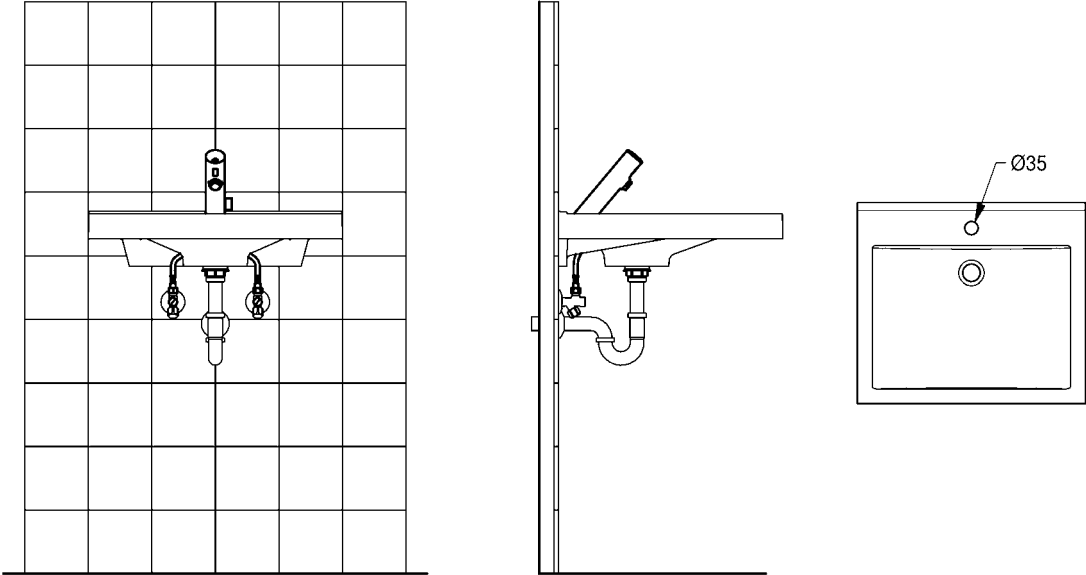

F3EM1002

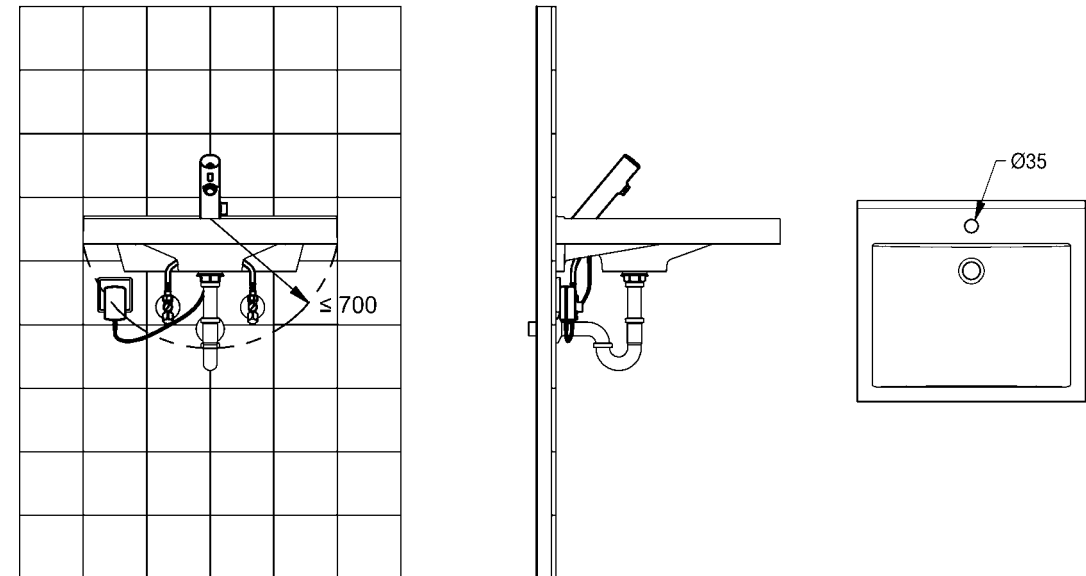

F3EM1003, F3EM1005

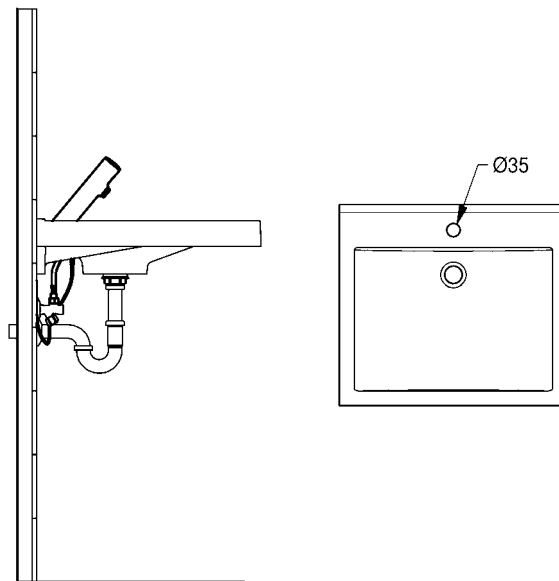
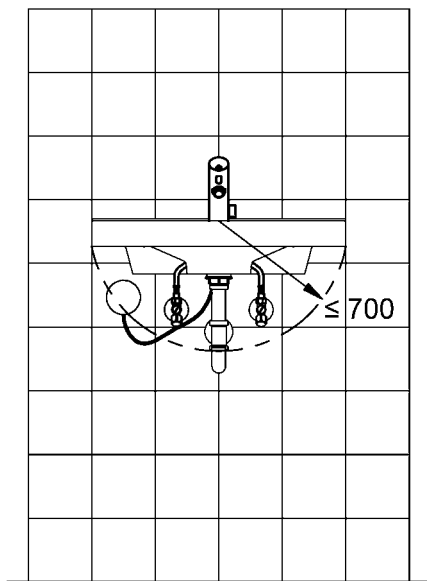

EN Installation and operating instructions

Important notes

- ▶ All work must be carried out in a de-energised state.
- ▶ Before installing flush piping system!
- ▶ After completing the installation, set the temperature limiter!
- ▶ The fitting must be operated only with original mesh filters and return flow inhibitors!
- ▶ The fitting must be checked and maintained at regular intervals depending on the water quality and in accordance with the local conditions, and rules and regulations applicable at the site.

Technical data

- ▶ Minimum flow pressure 1.0 bar
- ▶ Maximum operating pressure 10 bar
- ▶ Recommended flow pressure 1-5 bar
- ▶ Volume flow at 3 bar flow pressure 6 l/min
- ▶ maximum operating temperature
 - continuous operation 70 °C
 - short-term (<10 min) 80 °C
- ▶ F3EM1001: Voltage supply with lithium battery CRP2 6 V DC
- ▶ F3EM1002, F3EM1003: Supply voltage 110-240 V AC
- ▶ F3EM1005: Supply voltage 6,75 / 12 V DC
- ▶ Power consumption 1,5 W
- ▶ Type of protection fitting IP 59K

DE Montage- und Betriebsanleitung

Wichtige Hinweise

- ▶ Alle Arbeiten im spannungsfreien Zustand durchführen.
- ▶ Vor Installation Rohrleitungen spülen!
- ▶ Nach erfolgter Montage den Temperaturanschlag einstellen!
- ▶ Armatur nur mit original Sieben und Rückflussverhinderern betreiben!
- ▶ In Abhängigkeit von der Wasserqualität, den örtlichen Gegebenheiten und den vor Ort geltenden Bestimmungen die Armatur in regelmäßigen Abständen prüfen und warten.

Technische Daten

- ▶ Mindestfließdruck 1,0 bar
- ▶ Maximaler Betriebsdruck 10 bar
- ▶ Empfohlener Fließdruck 1-5 bar
- ▶ Volumenstrom bei 3 bar Fließdruck 6 l/min
- ▶ maximale Betriebstemperatur
 - Dauerbetrieb 70 °C
 - Kurzzeit (<10 min) 80 °C
- ▶ F3EM1001: Spannungsversorgung Lithium Batterie CRP2 6 V DC
- ▶ F3EM1002, F3EM1003: Anschlussspannung 110-240 V AC
- ▶ F3EM1005: Anschlussspannung 6,75 / 12 V DC
- ▶ Leistungsaufnahme 1,5 W
- ▶ Schutzart Armatur IP 59K

Ważne wskazówki

- ▶ Wszystkie prace przeprowadzać po odłączeniu zasilania elektrycznego.
- ▶ Przed instalacją przepłukać rury!
- ▶ Po zakończeniu montażu ustawić ograniczenie temperatury!
- ▶ Armatury należy używać wyłącznie z oryginalnymi sitkami i zaworami zwrotnymi!
- ▶ Armaturę należy poddawać regularnej kontroli i konserwacji w zależności od jakości wody, warunków lokalnych i obowiązujących przepisów.

Dane techniczne

- ▶ Minimalne ciśnienie przepływu 1,0 bar
- ▶ Maksymalne ciśnienie robocze 10 barów
- ▶ Zalecane ciśnienie przepływu 1-5 barów
- ▶ Objętościowe natężenie przepływu przy ciśnieniu 3 barów 6 l/min
- ▶ Maksymalna temperatura eksploatacji
 - Praca stała 70 °C
 - Czas krótki (<10 min) 80 °C
- ▶ F3EM1001: Zasilanie elektryczne baterią litową CRP2 6 V DC
- ▶ F3EM1002, F3EM1003: Napięcie przyłączeniowe 110-240 V AC
- ▶ F3EM1005: Napięcie przyłączeniowe 6,75 / 12 V DC
- ▶ Pobór mocy 1,5 W
- ▶ Rodzaj ochrony armatura IP 59K

Viktiga informationer

- ▶ Genomför alla arbeten i spänningslöst tillstånd.
- ▶ Spola igenom rörledningarna före installation!
- ▶ När monteringen har gjorts skall temperaturbegränsningen ställas in!
- ▶ Använd armaturen endast med originalsilar och originalåterflödesförhindrare!
- ▶ Kontrollera och serva armaturen med intervaller som bestäms av vattenkvaliteten samt de lokala förhållandena och de bestämmelser som gäller där.

Tekniska data

- ▶ Minsta hydrauliska tryck 1,0 bar
- ▶ Maximalt drifttryck 10 bar
- ▶ Rekommenderat hydrauliskt tryck 1-5 bar
- ▶ Volymström vid 3 bar hydrauliskt tryck 6 l/min
- ▶ Maximal driftstemperatur
 - Kontinuerlig drift 70 °C
 - Kort tid (< 10 min) 80 °C
- ▶ F3EM1001: Spänningsförsörjning med litiumbatteri CRP2 6 V DC
- ▶ F3EM1002, F3EM1003: Anslutningsspänning 110-240 V AC
- ▶ F3EM1005: Anslutningsspänning 6,75 / 12 V DC
- ▶ Effektbehov 1,5 W
- ▶ Skyddsklass armatur IP 59K

Remarques importantes

- ▶ Effectuez tous les travaux quand le dispositif est hors tension.
- ▶ Rincer les conduites avant d'installer !
- ▶ Une fois le montage terminé, régler la limitation de température !
- ▶ Ne faire fonctionner la robinetterie qu'avec les filtres et clapets de non retour d'origine !
- ▶ En fonction de la qualité de l'eau, ainsi que des conditions et des dispositions locales, il convient de contrôler et d'entretenir la robinetterie à intervalles réguliers.

Données techniques

- ▶ Pression dynamique minimale 1,0 bar
- ▶ Pression de service maximale 10 bars
- ▶ Pression dynamique recommandée 1-5 bars
- ▶ Débit volumique pour 3 bars de pression dynamique 6 l/min
- ▶ Température de fonctionnement maximale
 - Fonctionnement continu 70 °C
 - Courte période (< 10 min) 80 °C
- ▶ F3EM1001: Alimentation en tension avec pile au lithium CRP2 6 V DC
- ▶ F3EM1002, F3EM1003: Tension de raccordement 110-240 V AC
- ▶ F3EM1005: Tension de raccordement 6,75 / 12 V DC
- ▶ Puissance absorbée 1,5 W
- ▶ Type de protection robinetterie IP 59K

Důležité pokyny

- ▶ Veškeré práce vykonávejte ve stavu bez napětí.
- ▶ Před instalací potrubí propláchněte!
- ▶ Po provedené montáži nastavit omezení teploty!
- ▶ Provozovat armaturu jen s originálními sítky a zařízeními proti zpětnému toku!
- ▶ V závislosti na kvalitě vody, místních podmínkách a předpisech platných v místě instalace je nutné provádět v pravidelných intervalech kontrolu a údržbu armatury.

Technické údaje

- ▶ Minimální průtočný tlak 1,0 bar
- ▶ Maximální provozní tlak 10 bar
- ▶ Doporučený průtočný tlak 1-5 bar
- ▶ Průtok při průtočném tlaku 3 bar 6 l/min
- ▶ Maximální provozní teplota
 - Doba provozu 70 °C
 - Krátký čas (< 10 min.) 80 °C
- ▶ F3EM1001: Napájení lithiovou baterií CRP2 6 V DC
- ▶ F3EM1002, F3EM1003: Přípojně napětí 110-240 V AC
- ▶ F3EM1005: Přípojně napětí 6,75 / 12 V DC
- ▶ Příkon 1,5 W
- ▶ Krytí Armatura IP 59K

ES

Instrucciones de montaje y servicio

Indicaciones importantes

- ▶ Todos los trabajos deben realizarse con la tensión de alimentación desconectada.
- ▶ ¡Enjuagar las tuberías antes de instalar!
- ▶ ¡Ajuste el límite de temperatura tras realizar el montaje!
- ▶ ¡La grifería debe hacerse funcionar únicamente con los tamices y las válvulas antiretorno originales!
- ▶ En función de la calidad del agua, las condiciones locales y la legislación vigente, realizar las inspecciones y el mantenimiento de la grifería a intervalos regulares.

Datos técnicos

- ▶ Presión mínima de flujo 1,0 bar
- ▶ Presión máxima de servicio 10 bares
- ▶ Presión de flujo recomendada 1-5 bares
- ▶ Flujo volumétrico con 3 bares de presión de flujo 6 l/min
- ▶ Temperatura de servicio máxima
 - Funcionamiento continuo 70 °C
 - Tiempo breve (< 10 min) 80 °C
- ▶ F3EM1001: Alimentación de corriente con batería de litio CRP2 6 V DC
- ▶ F3EM1002, F3EM1003: Tensión de conexión 110-240 V AC
- ▶ F3EM1005: Tensión de conexión 6,75 / 12 V DC
- ▶ Consumo de potencia 1,5 W
- ▶ Modo de protección grifería IP 59K

FI

Asennus- ja käyttöohje

Tärkeitä ohjeita

- ▶ Kaikki työt on tehtävä jännitteettömälle järjestelmälle.
- ▶ Huuhtele putkijohdot ennen asennusta!
- ▶ Säädä asennuksen jälkeen lämpötilan rajoitus!
- ▶ Käytä varusteet vain alkuperäisten sihtien ja takaisinvirtauksen eston kanssa!
- ▶ Hana tulee tarkistaa ja huoltaa säännöllisin väliajoin veden laadusta, paikallisista oloista ja paikalla voimassa olevista määräyksistä riippuen.

Tekniset tiedot

- ▶ Vähimmäisvirtauspaine 1,0 bar
- ▶ Suurin käyttöpaine 10 bar
- ▶ Suositeltava virtauspaine 1-5 bar
- ▶ Tilavuusvirta 3 barin virtauspaineella 6 l/min
- ▶ Maksimaalinen käyttölämpötila
 - Jatkuva käyttö 70 °C
 - Lyhyt aika (<10 min) 80 °C
- ▶ F3EM1001: Jännitteensyöttö litiumparistolla CRP2 6 V DC
- ▶ F3EM1002, F3EM1003: Verkkojännite 110-240 V AC
- ▶ F3EM1005: Verkkojännite 6,75 / 12 V DC
- ▶ Tehonkulutus 1,5 W
- ▶ Suojaustapa Kalusteet IP 59K

IT

Istruzioni per il montaggio e l'uso

Avvertenze importanti

- ▶ Eseguire tutti i lavori fuori tensione.
- ▶ Sciacquare le tubazioni prima di installare!
- ▶ Una volta terminata l'installazione, impostare la limitazione di temperatura!
- ▶ Utilizzare la rubinetteria esclusivamente con i filtri e le valvole antiriflusso originali!
- ▶ Controllare e sottoporre a manutenzione l'apparecchio ad intervalli regolari, in funzione della qualità dell'acqua, delle caratteristiche locali e delle vigenti disposizioni locali.

Specifiche tecniche

- ▶ Pressione idraulica min. 1,0 bar
- ▶ Pressione di esercizio max. 10 bar
- ▶ Pressione idraulica consigliata 1-5 bar
- ▶ Portata volumetrica a 3 bar di pressione idraulica 6 l/min
- ▶ Temperatura massima di esercizio
 - Funzionamento continuo 70 °C
 - Brevemente (<10 min) 80 °C
- ▶ F3EM1001: Alimentazione di tensione con batteria al litio CRP 2 di 6 V DC
- ▶ F3EM1002, F3EM1003: Tensione di allacciamento 110-240 V AC
- ▶ F3EM1005: Tensione di allacciamento 6,75 / 12 V DC
- ▶ Potenza assorbita 1,5 W
- ▶ Tipo di protezione rubinetteria IP 59K

RU

Инструкция по монтажу и вводу в эксплуатацию

Важные указания

- ▶ Выполняйте все работы при отключенном напряжении.
- ▶ Перед инсталляцией промыть трубки!
- ▶ После монтажа отрегулировать температурный предел!
- ▶ Эксплуатировать арматуру только с оригинальными фильтрами и клапанами обратного течения!
- ▶ Арматуру необходимо регулярно чистить и обслуживать в зависимости от качества воды, местных условий и действующих в месте эксплуатации предписаний.

Технические характеристики

- ▶ Минимальный гидравлический напор 1,0 бар
- ▶ Максимальное рабочее давление 10 бар
- ▶ Рекомендуемый гидравлический напор 1-5 бар
- ▶ Объёмный расход при гидравлическом напоре 3 бар 6 л/мин
- ▶ Максимальная рабочая температура
 - Непрерывный режим работы 70 °C
 - Короткое время (<10 мин) 80 °C
- ▶ F3EM1001: Источник питания - литиевая батарея CRP 2 6 В постоянного тока
- ▶ F3EM1002, F3EM1003: Напряжение питающей сети 230 В переменного тока
- ▶ F3EM1005: Напряжение питающей сети 6,75 / 12 В постоянного тока
- ▶ Потребляемая мощность 1,5 Вт
- ▶ Вид защиты Арматура IP 59K

Belangrijke aanwijzingen

- ▶ Alle werkzaamheden in spanningsloze toestand uitvoeren.
- ▶ Voor installatie buisleidingen spoelen!
- ▶ Na de montage de temperatuurbegrenzing instellen!
- ▶ Armatuur alleen met originele zeven en terugstroomkleppen gebruiken!
- ▶ Afhankelijk van de waterkwaliteit, de plaatselijke omstandigheden en de plaatselijke voorschriften de armatuur regelmatig controleren en onderhouden.

Technische gegevens

- ▶ Minimale dynamische druk 1,0 bar
- ▶ Maximale werkdruk 10 bar
- ▶ Aanbevolen dynamische druk 1-5 bar
- ▶ Volumestroom bij 3 bar dynamische druk 6 l/min
- ▶ Maximale bedrijfstemperatuur
 - Continubedrijf 70 °C
 - Kortstondig (<10 min) 80 °C
- ▶ F3EM1001: Spanningsvoorziening d.m.v. lithiumbatterij CRP2 6 V DC
- ▶ F3EM1002, F3EM1003: Aansluitspanning 110-240 V AC
- ▶ F3EM1005: Aansluitspanning 6,75 / 12 V DC
- ▶ Opgenomen vermogen 1,5 W
- ▶ Veiligheidsgraad armatuur IP 59K



1. Montage

EN Installation
FR Montage
ES Montaje
IT Montaggio

NL Montage
PL Montaż
SV Montering

CS Montáž
FI Asennus
RU Монтаж



 13 mm

 19 mm

1

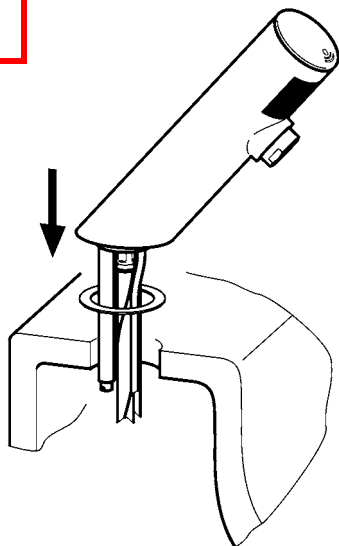

2

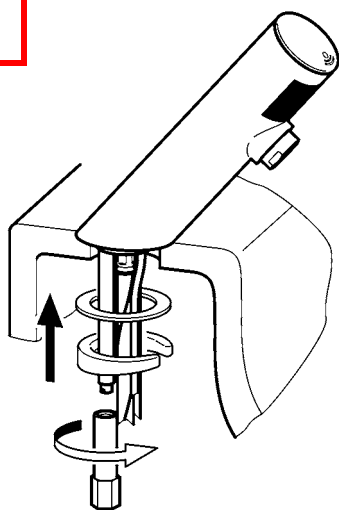

3

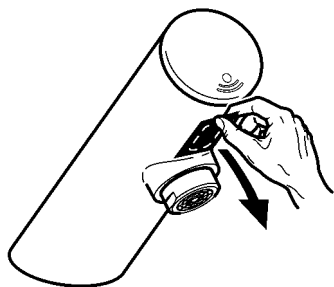

4

F3EM1001

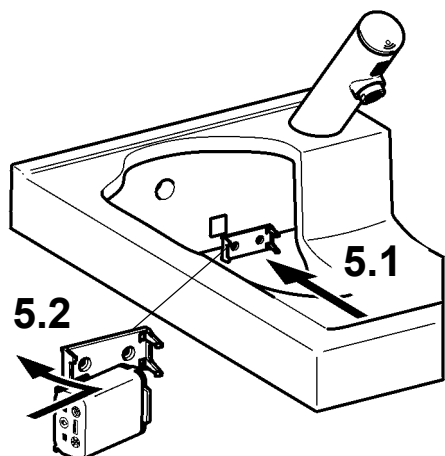

F3EM1002

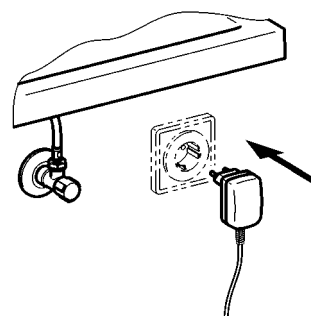

F3EM1003

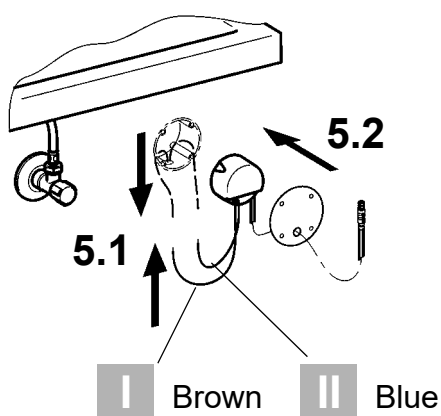

F3EM1005

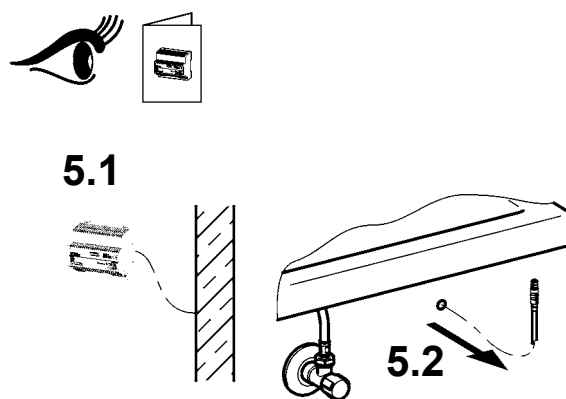

EN | Brown = L
II Blue = N

ES | Bruna = L
II Azul = N

PL | Brązowy = L
II Niebieski = N

FI | Ruskea = L
II Sininen = N

DE | Braun = L
II Blau = N

IT | Bruno = L
II Blu = N

SV | Brun = L
II Blå = N

RU | коричневый = L
II голубой = N

FR | Brun = L
II Bleu = N

NL | Bruin = L
II Blauw = N

CS | Hnědý = L
II Modrý = N

5

F3EM1001

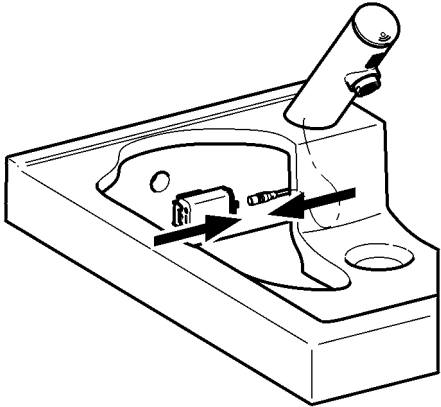

F3EM1002

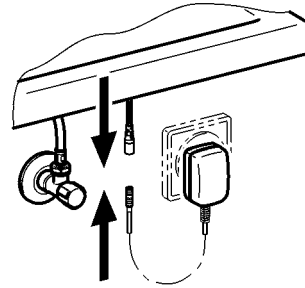

F3EM1003

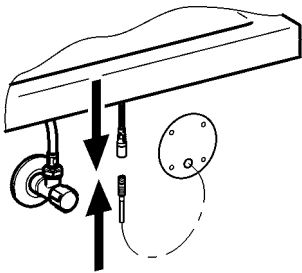

F3EM1005

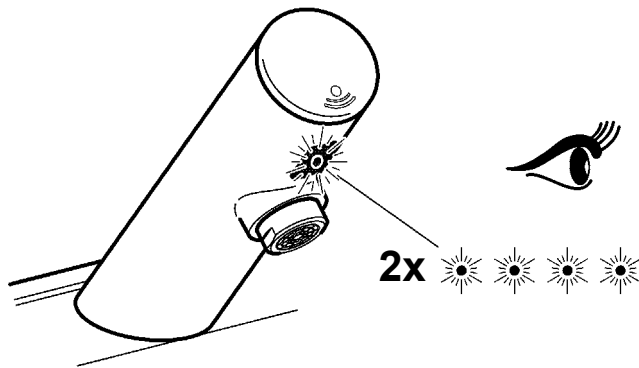
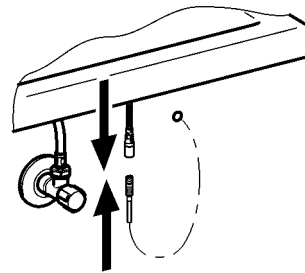

6

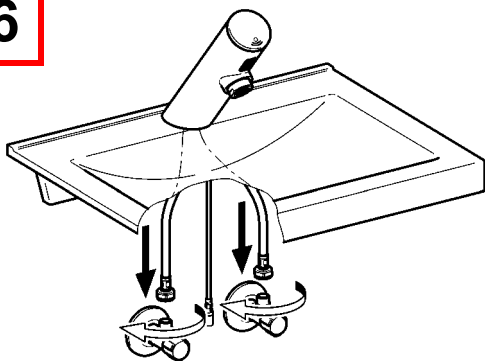

7

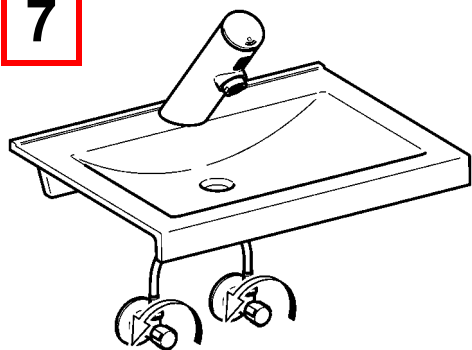

2. Funktion

EN Function
FR Fonctionnement
ES Función
IT Funzionamento

NL Werking
PL Funkcja
SV Funktion

CS Funkce
FI Toiminto
RU Функционирование

1

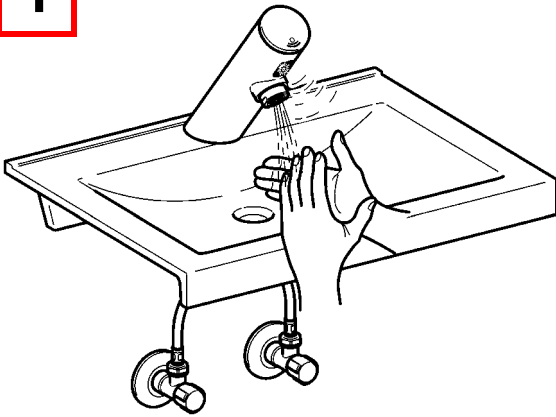

2

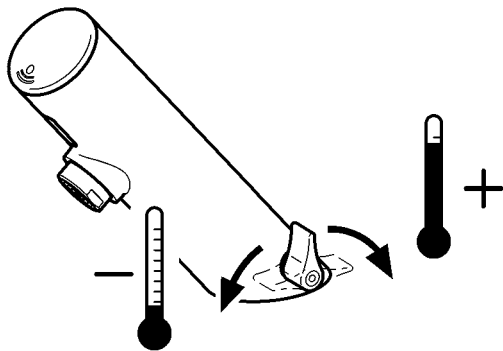
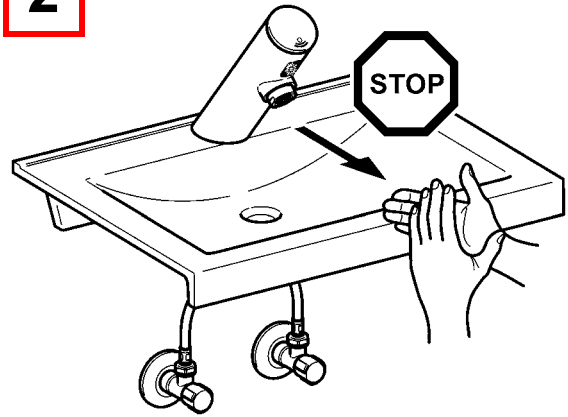

3. Hygienspülung ein- / ausschalten

EN Switching hygiene flushing on/off	NL Hygiënische spoeling in-/uitschakelen	CS Zapněte/vypněte hygienické propláchnutí
FR Activer/désactiver le rinçage hygiénique	PL Włączyć/wyłączyć splukiwanie higieniczne	FI Hygieniahuuhdelun päälle-/ pois päältä kytkeminen
ES Activar/Desactivar el higiene enjuague	SV Koppla hygienspolningen till / från	RU Гигиеническое промывание включить/выключить
IT Attivare/disattivare lo igiene risciacquo		

- EN**
- ▶ Ensure open outlet.
 - ▶ After 24h of non-use, water flows 30 s.
- DE**
- ▶ Freien Auslauf gewährleisten.
 - ▶ Nach 24h Nichtbenutzung fließt 30 s Wasser.
- FR**
- ▶ Garantir un écoulement libre.
 - ▶ L'eau s'écoule pendant 30 s. après 24h de non utilisation.
- ES**
- ▶ Garantizar una salida libre.
 - ▶ Si no se realiza ningún uso durante 24 horas, fluye agua durante 30 seg.
- IT**
- ▶ Garantire l'erogazione libera.
 - ▶ Dopo 24h di inutilizzo scorre acqua per 30 s.
- NL**
- ▶ Vrije uitloop garanderen.
 - ▶ Na 24 uur niet te zijn gebruikt stroomt er gedurende 30 s. water.
- PL**
- ▶ Zapewnić swobodny wylot.
 - ▶ Po 24 godz. niekorzystania przez 30 s. wypływa woda.
- SV**
- ▶ Garantera fritt avlopp.
 - ▶ Vatten flyter 30 s efter 24 timmars användningspaus.
- CS**
- ▶ Zajistěte volný odtok.
 - ▶ Při nepoužívání 24 h nechte 30 s téct vodu.
- FI**
- ▶ Vapaan virtauksen takaaminen.
 - ▶ Käyttämättömänä 24 h jälkeen virtaa vettä 30 s.
- RU**
- ▶ Обеспечить беспрепятственный слив
 - ▶ После того, как устройство не используется в течение 24 ч, в течение 30 сек течёт вода.

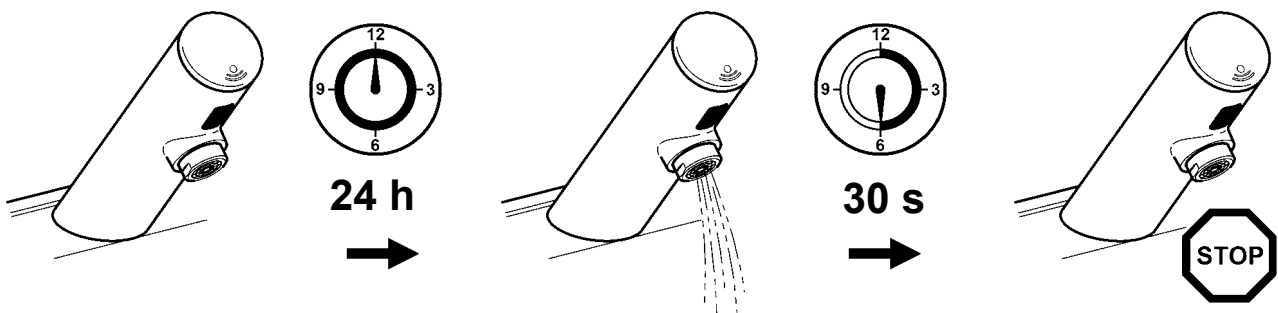

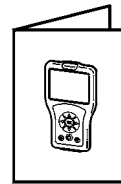
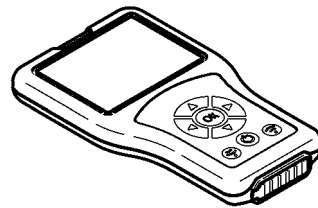
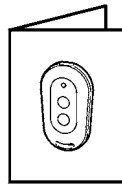
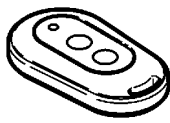
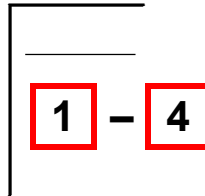
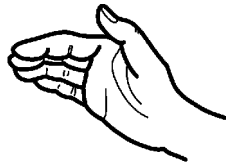

1

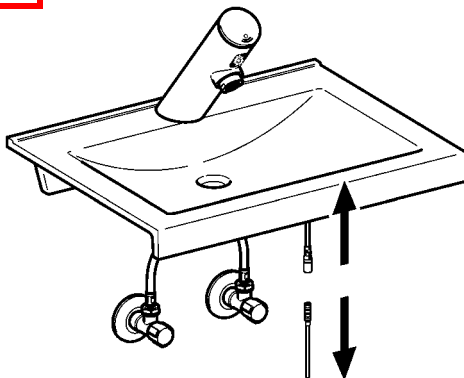

2

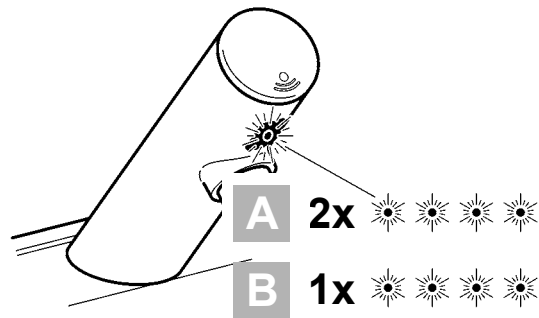
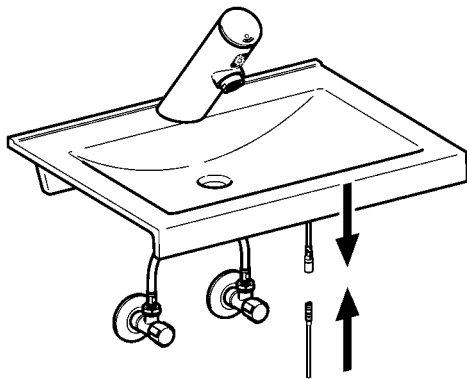
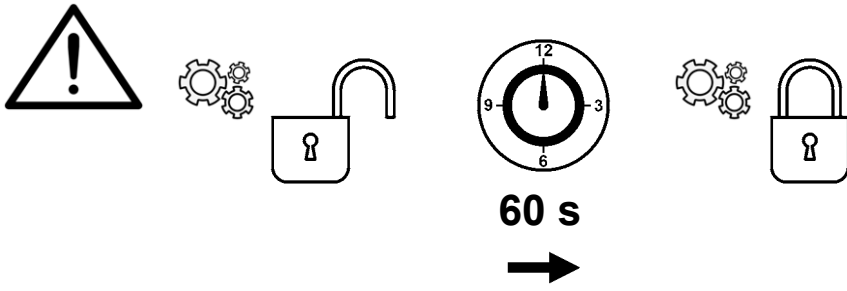

3

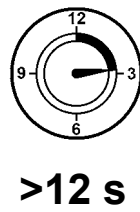
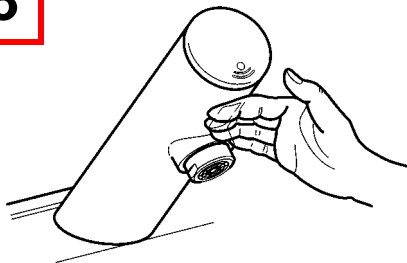

4

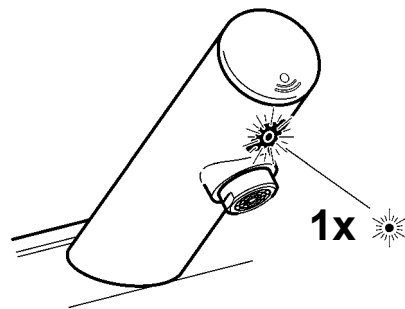
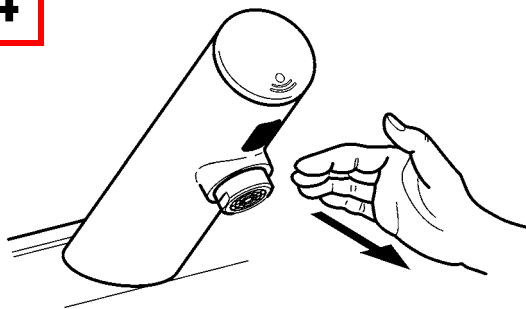

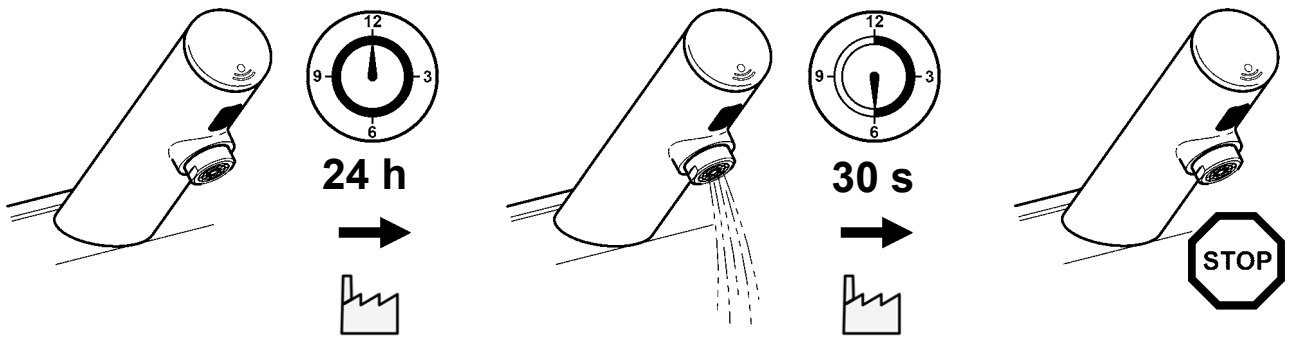
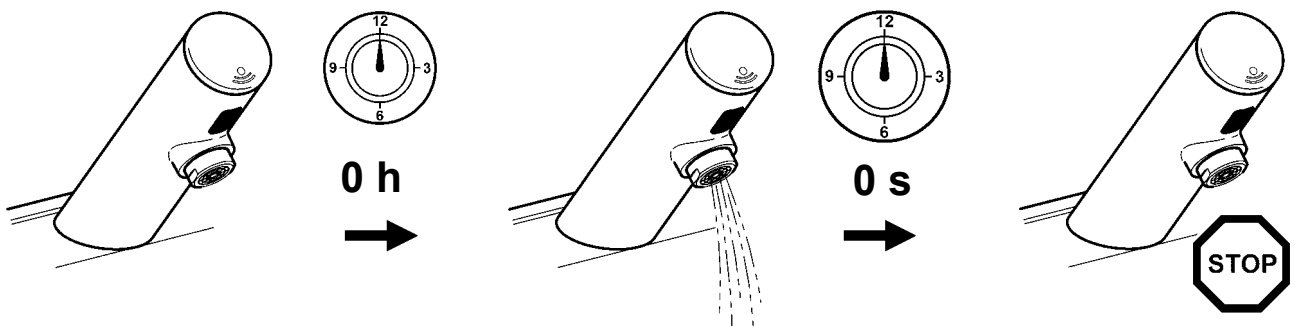
A**B**

4. Armatur ausschalten

EN Switch off the valve

FR Désactiver la robinetterie

ES Desconectar la grifería

IT Disattivazione della rubinetteria

NL Armatuur uitschakelen

PL Wyłączenie baterii

SV Avstängning av armatur

CS Vypnout armaturu

FI Laitteen kytkeminen pois päältä

RU отключить оборудование

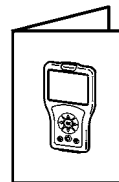
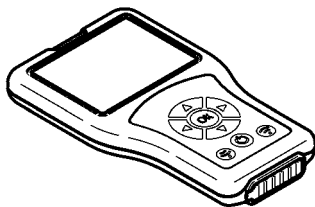

5. Dauerlauf starten

EN Start continual flow

NL Continue stroming starten

CS Spustit trvalý provoz

FR Démarrer la marche continue

PL Uruchomić stały wypływ wody

FI Tuotantokäytön aloittaminen

ES Iniciar el enjuague continuo

SV Starta kontinuerlig drift

RU запустить ресурс

IT Avviare l'erogazione continua

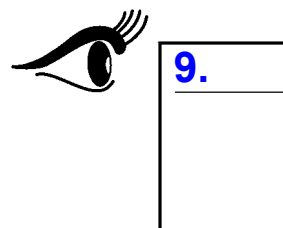
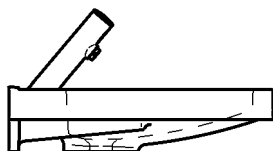
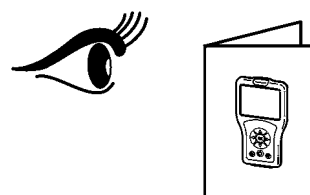
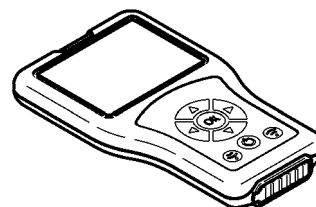
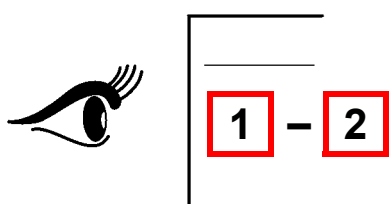
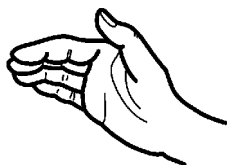

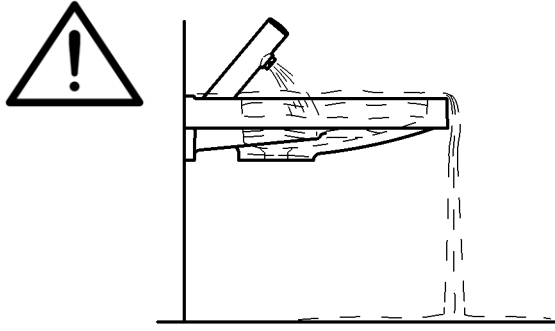

1

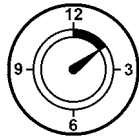
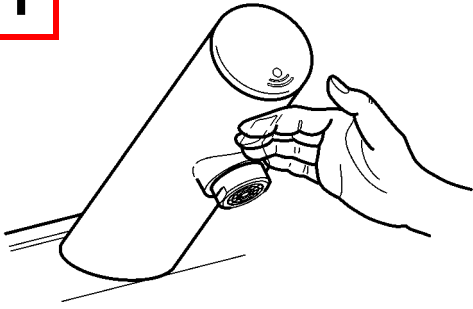

5 - 8 s

2

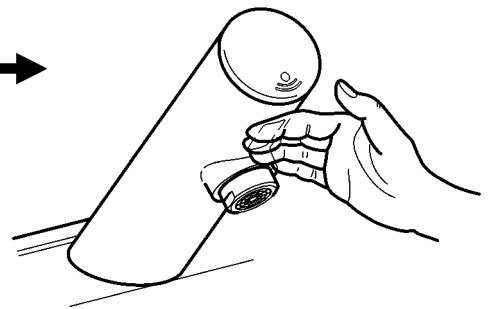
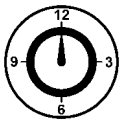
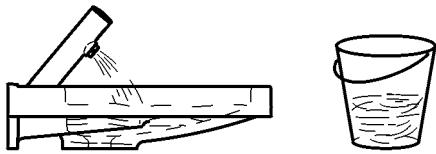
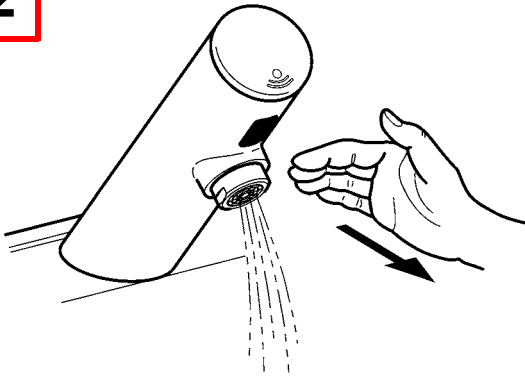

6. Reinigungsabschaltung einschalten

EN Switch on cleaning switch-off	NL Inschakelen van de reiniging shutdown	CS Vypínač pro čištění
FR Activer l'arrêt de nettoyage	PL Włączanie wyłączenia na czas czyszczenia	FI Aktivoida pesuseisokkien
ES Activar el apagado de limpieza	SV Aktivera rengörings avstängning	RU активировать чистка завершение работы
IT Attivare dello spegnimento per pulizia		

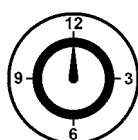
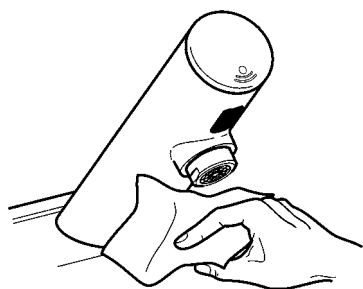
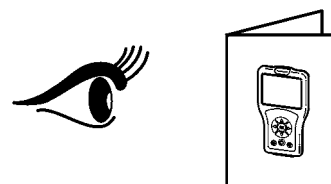
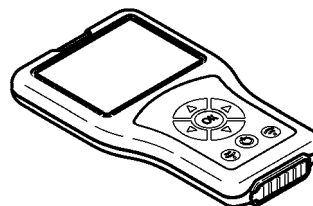
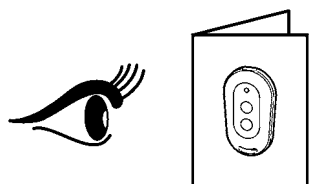

1 min

7. Reichweite einstellen

EN Adjusting the range

FR Réglage de la portée

ES Ajuste del alcance

IT Impostazione della portata

NL Actieradius instellen

PL Ustawienie zasięgu

SV Ställa in räckvidden

CS Nastavení dosahu

FI Tunnistusetäisyyden säätäminen

RU Настройка дальности действия

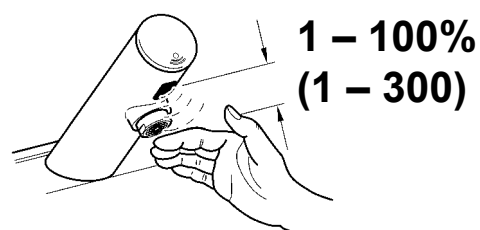
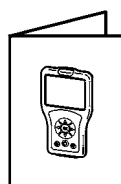
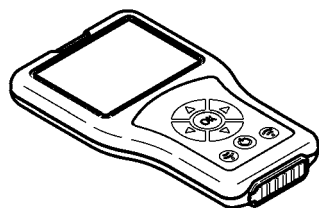
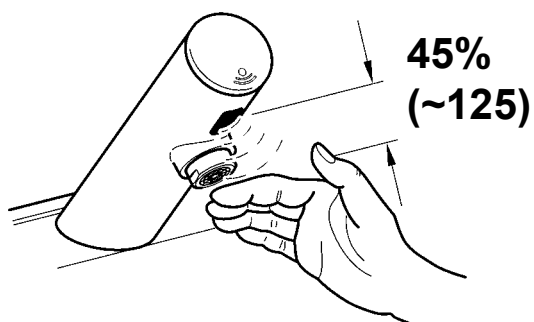

8. Hygienespülung einstellen

EN Setting the hygiene flush	NL Instellen van de hygiënespoeling	CS Nastavení hygienického proplachování
FR Réglage de la rinçage d'hygiène	PL Ustawianie spłukiwania higienicznego	FI Hygieniahuuhtelun säätäminen
ES Ajuste del higiene enjuague	SV Ställa in hygienspolning	RU установив гигиена смыва
IT Impostare lo igiene risciacquo		

- EN**
- ▶ C: Interval adjustable in h
 - ▶ D: Flow duration adjustable in s
- DE**
- ▶ C: Intervall einstellbar in h
 - ▶ D: Fließzeit einstellbar in s
- FR**
- ▶ C: intervalle réglable en h
 - ▶ D: durée d'écoulement réglable en s
- ES**
- ▶ C: Intervalo ajustable en horas
 - ▶ D: Tiempo de flujo activable en seg
- IT**
- ▶ C: intervallo impostabile in h
 - ▶ D: durata di flusso impostabile in s
- NL**
- ▶ C: Interval instelbaar in u
 - ▶ D: Stromingstijd instelbaar in s
- PL**
- ▶ C: odstęp czasu regulowany w godzinach
 - ▶ D: czas przepływu regulowany w sekundach
- SV**
- ▶ C: Intervall kan ställas in i timmar
 - ▶ D: Flödestid kan ställas in i sekunder
- CS**
- ▶ C: Interval s nastavením v h
 - ▶ D: Doba průtoku s nastavením v s
- FI**
- ▶ C: Aikaväli, asetettavissa h
 - ▶ D: Virtausaika, asetettavissa s
- RU**
- ▶ C: интервал задается в ч
 - ▶ D: время течения задается в сек.

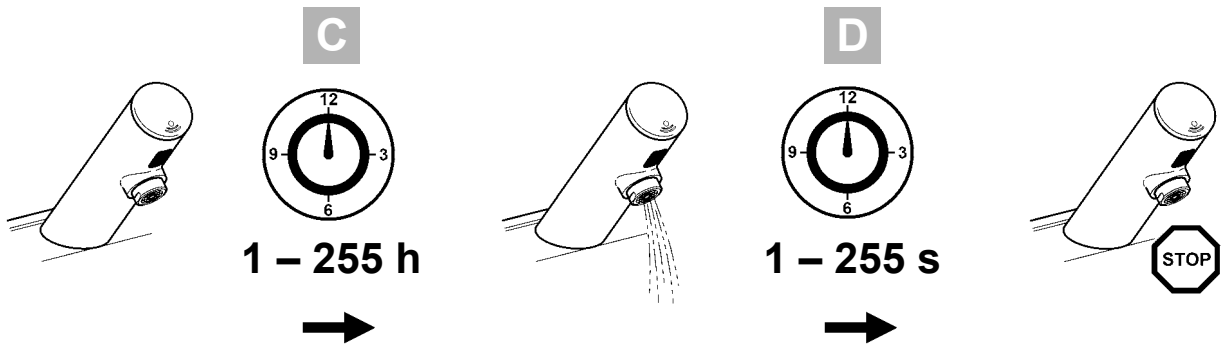
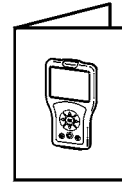
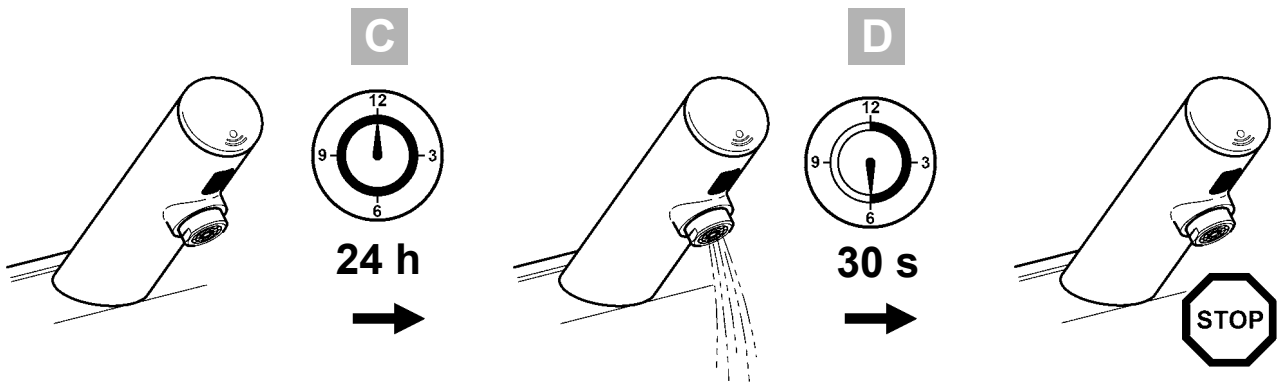

9. Dauerlauf einstellen

EN Setting continuous operating mode

NL Continue stroming instellen

CS Nastavení pomalejšího toku

FR Réglage du fonctionnement en continu

PL Ustawienie ciągłego wypływu

FI Tuotantokäytön säätäminen

ES Ajuste del funcionamiento ininterrumpido

SV Ställa in permanent flöde

RU Настройка непрерывного режима

IT Impostazione del flusso continuo

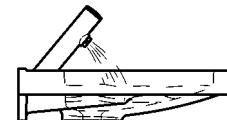
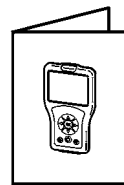
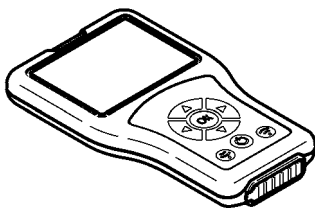
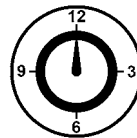
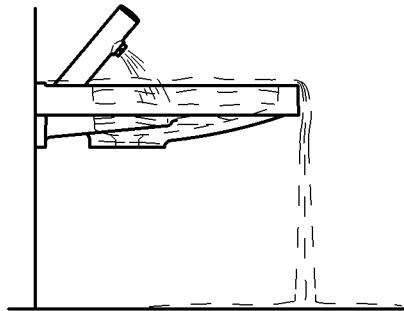
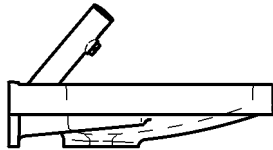

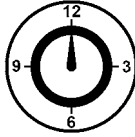
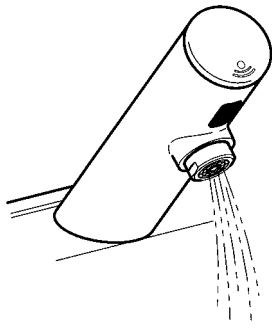

60 s

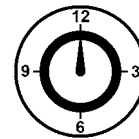
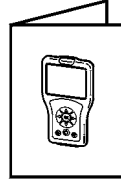
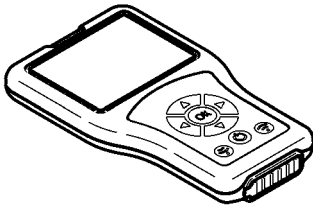

1 – 255 s

10. Reinigungsabschaltung einstellen

EN Adjusting the cleaning switch-off

NL Reinigungsuitschakeling instellen

CS Nastavení vypnutí za účelem čištění

FR Régler l'arrêt du nettoyage

PL Ustawianie funkcji wyłączenia na czas czyszczenia

FI Puhdistuskatkaisun säätäminen

ES Ajuste de la desconexión de limpieza

SV Ställa in rengörings avstängning

RU Настройка отключения для очистки

IT Impostazione dello spegnimento per pulizia

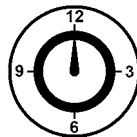
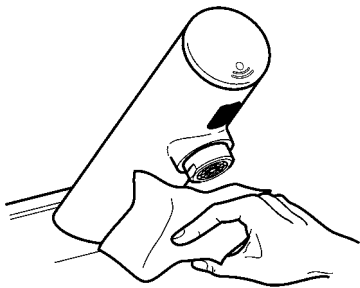

1 min

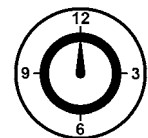
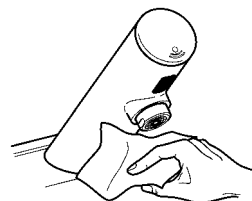
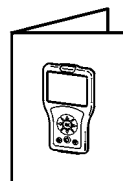
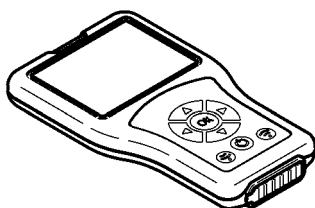

1 – 255 min

11. Temperaturanschlag einstellen

EN Setting the temperature stop	NL Temperatuurbegrenzing instellen	CS Nastavení teplotního limitu
FR Réglage de la butée de température	PL Ustawienie ograniczenia temperatury	FI Lämpötilarajoittimen säätäminen
ES Ajuste del tope de temperatura	SV Ställa in temperaturstoppet	RU Настройка температурного упора
IT Impostazione del blocco temperatura		



13 mm

2 mm

1

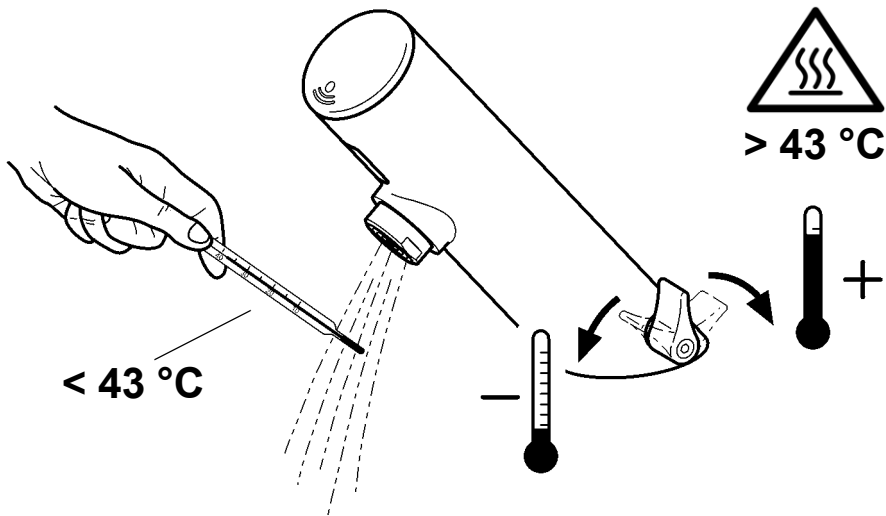

2

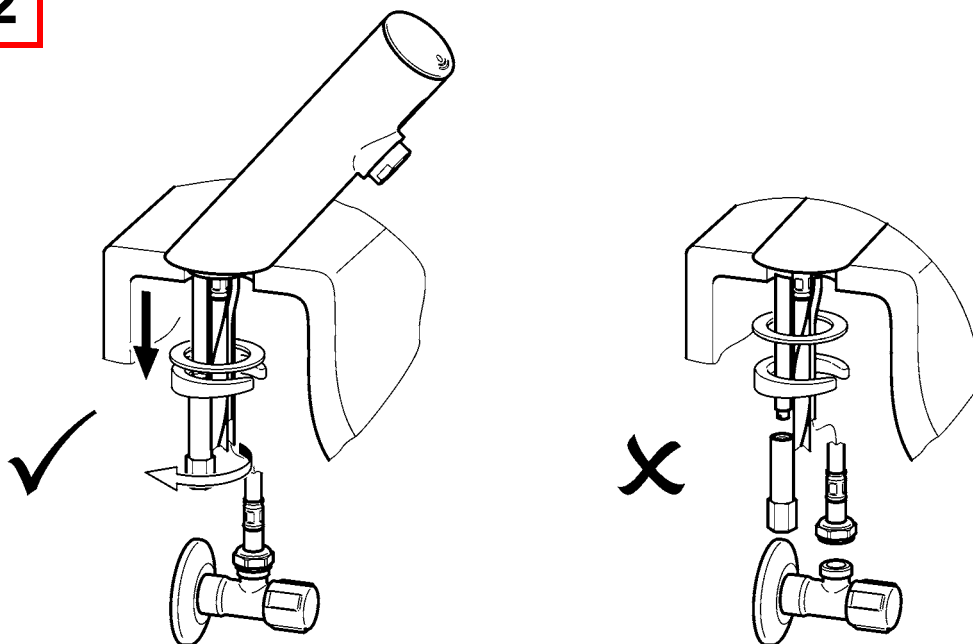

3

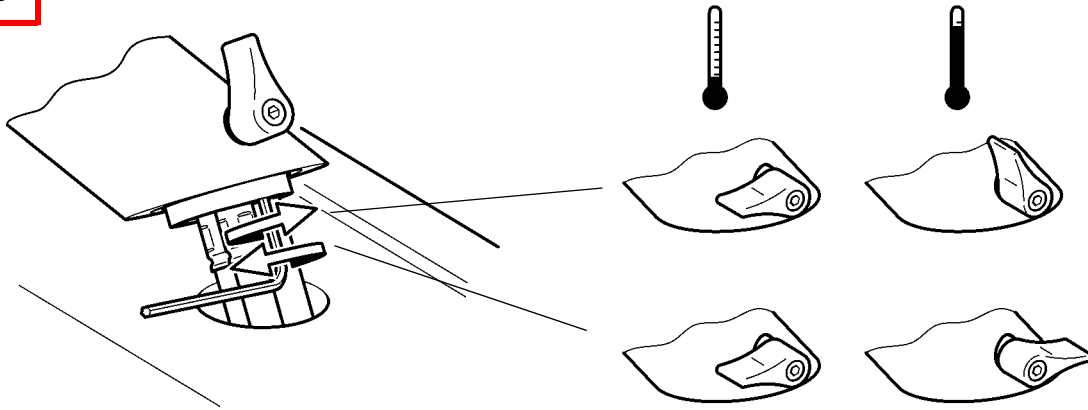

4

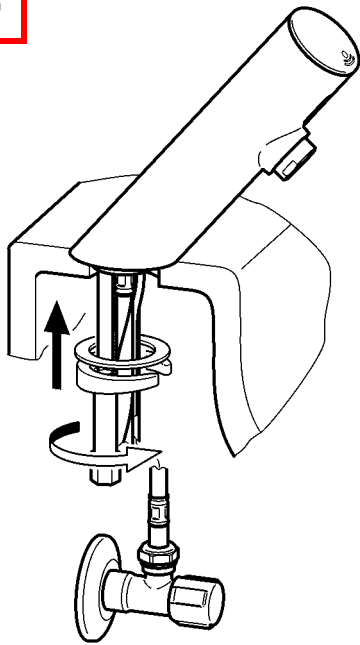

12. Wartung

EN Maintenance
FR Maintenance
ES Mantenimiento
IT Manutenzione

NL Onderhoud
PL Konserwacja
SV Underhåll

CS Varování
FI Huolto
RU Техническое обслуживание



13.

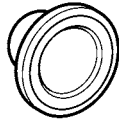

14.

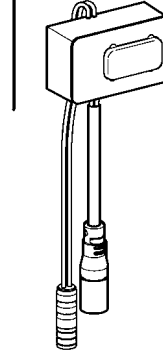

15.

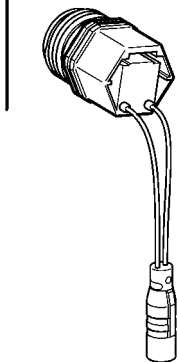

16.

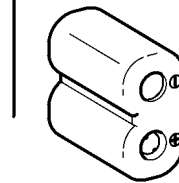

 22 mm

1

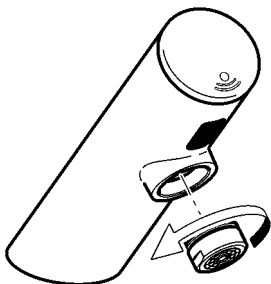

2

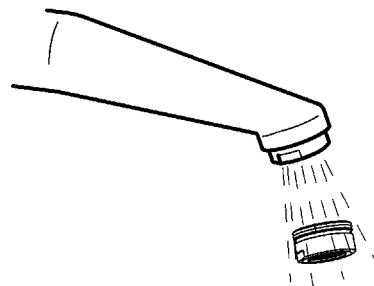

13. Sieb wechseln

EN Replace the filters

FR Remplacement les filtres

ES Cambiar los tamices

IT Sostituire i filtri

NL Zeven vervangen

PL Wymiana sit

SV Byt filter

CS Vyměňte síto

FI Siivilän vaihto

RU Сменить сеточки



 19 mm

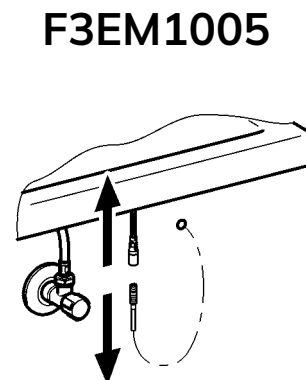
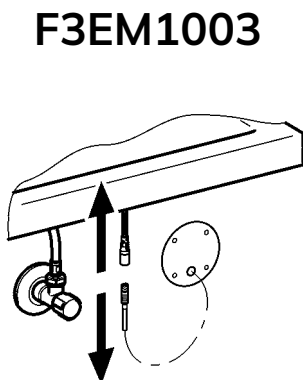
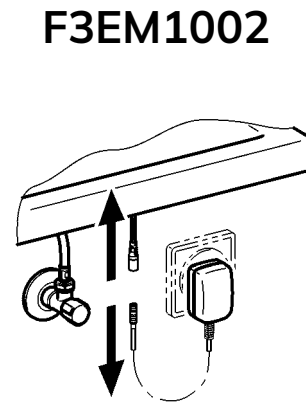
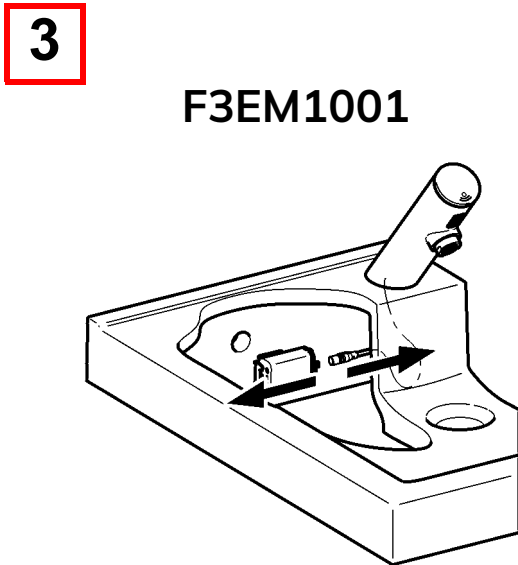
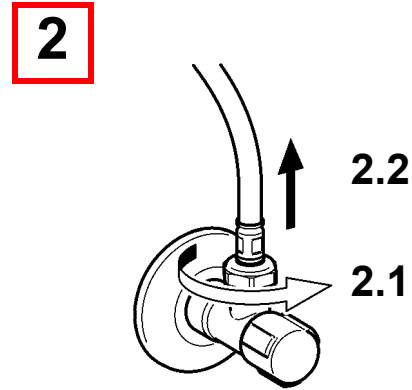
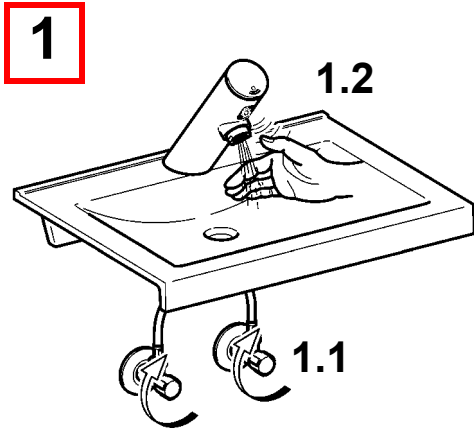

4

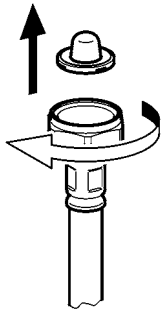

5

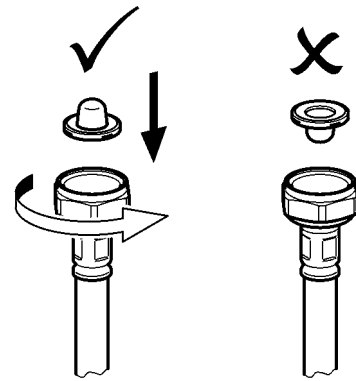

6

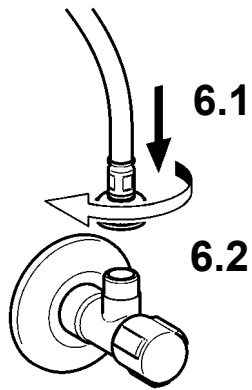

7

F3EM1001

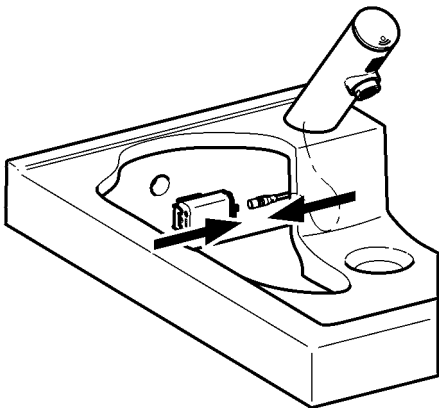

F3EM1002

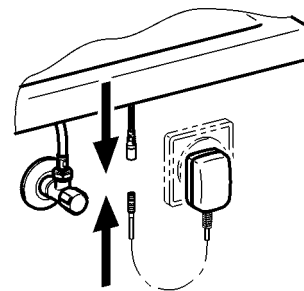

F3EM1003

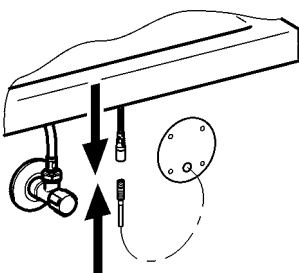

F3EM1005

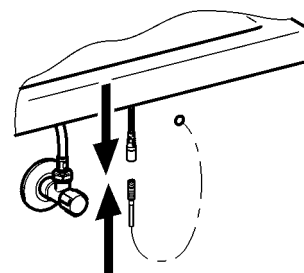

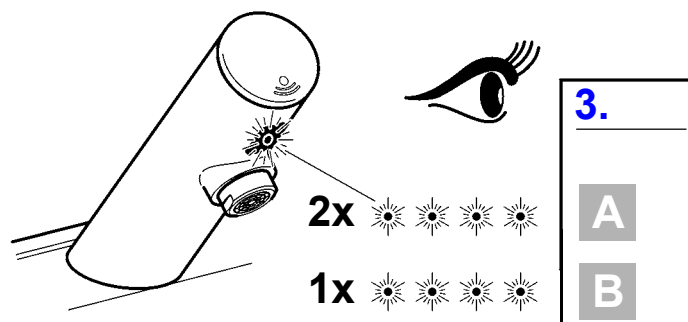

8

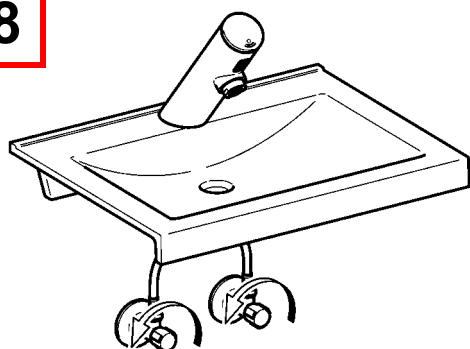

14. Sensor wechseln

EN Replace sensor
FR Changer le capteur
ES Cambiar el sensor
IT Cambiare il sensore

NL Sensor vervangen
PL Wymienić czujnik
SV Byt sensor

CS Vyměňte snímač
FI Anturi vaihto
RU Замена Датчик

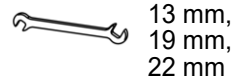
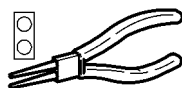
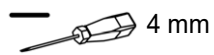

1

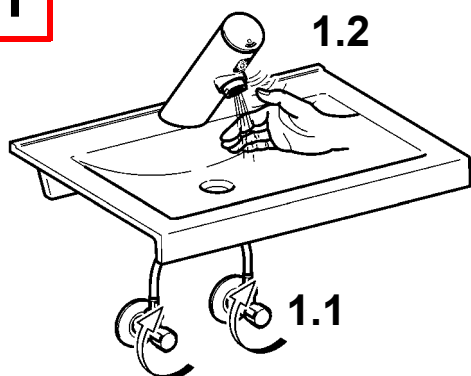

2

F3EM1001

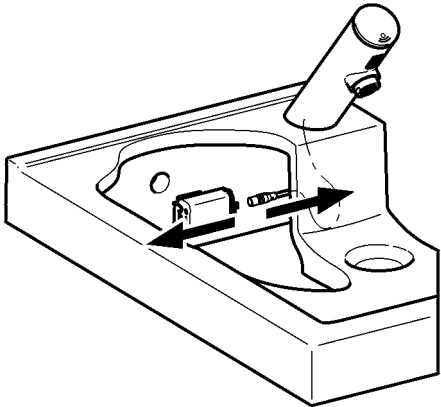

F3EM1002

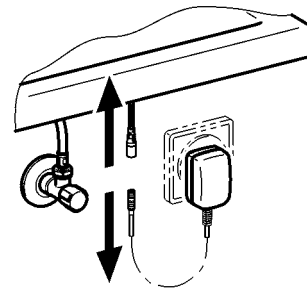

F3EM1003

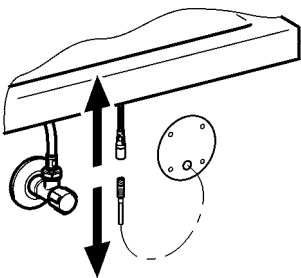

F3EM1005

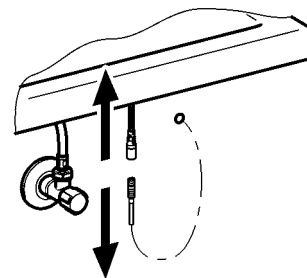

3

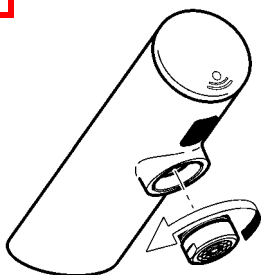

4

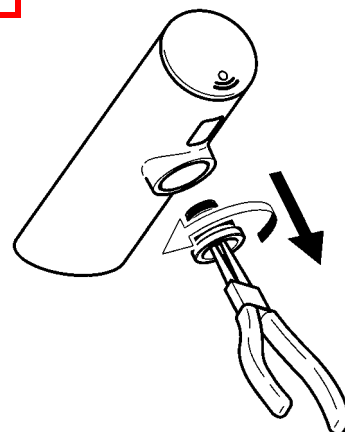

5

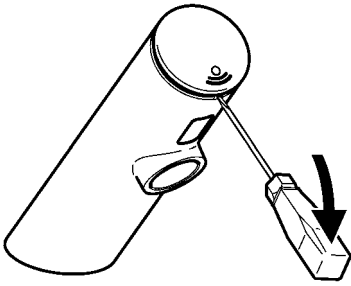

6

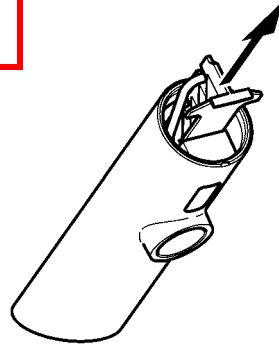

7

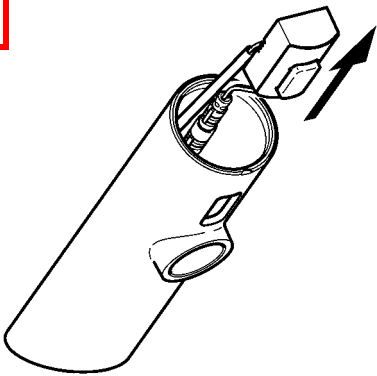

8

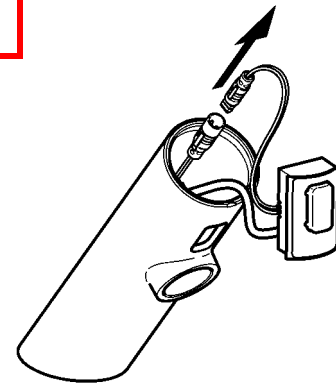

9

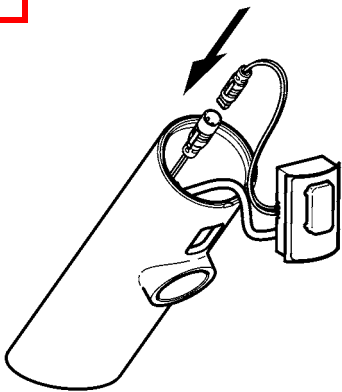

10

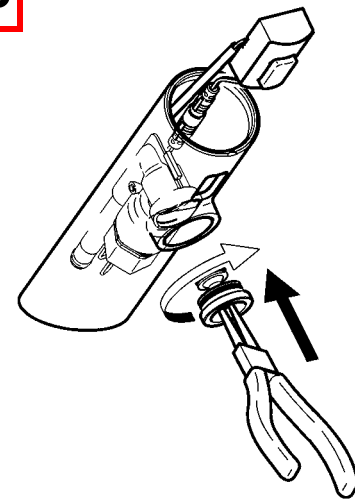

11

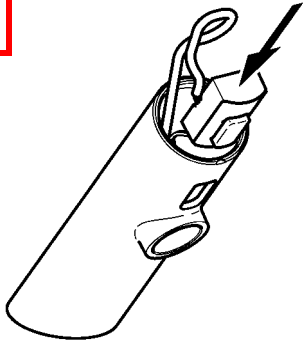

12

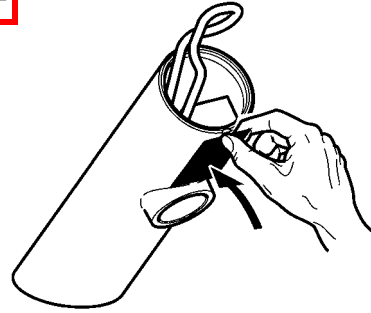

13

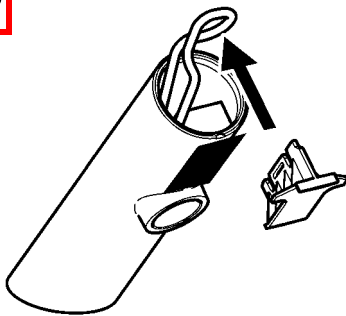

14

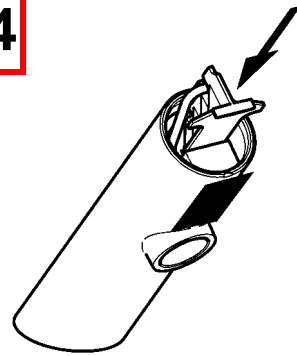

15

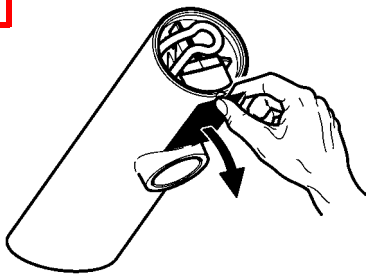

16

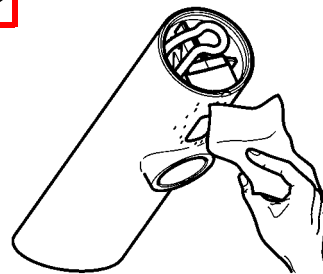

17

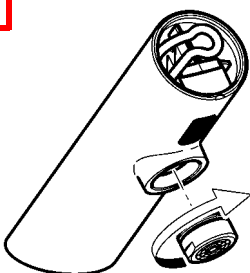

18

F3EM1001

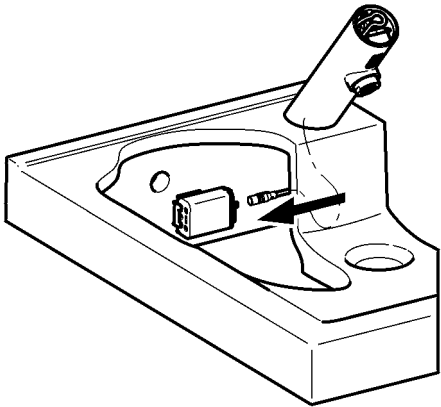

F3EM1002

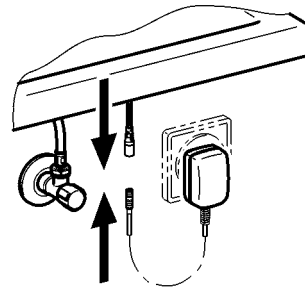

F3EM1003

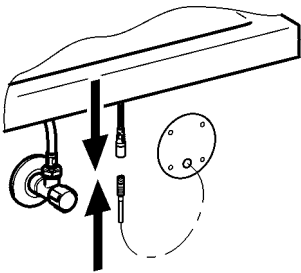

F3EM1005

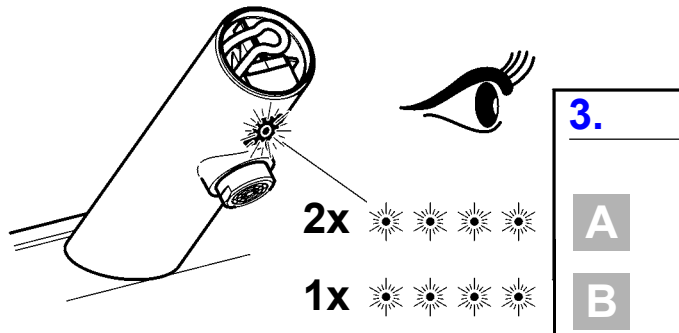
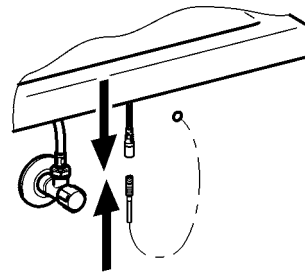

19

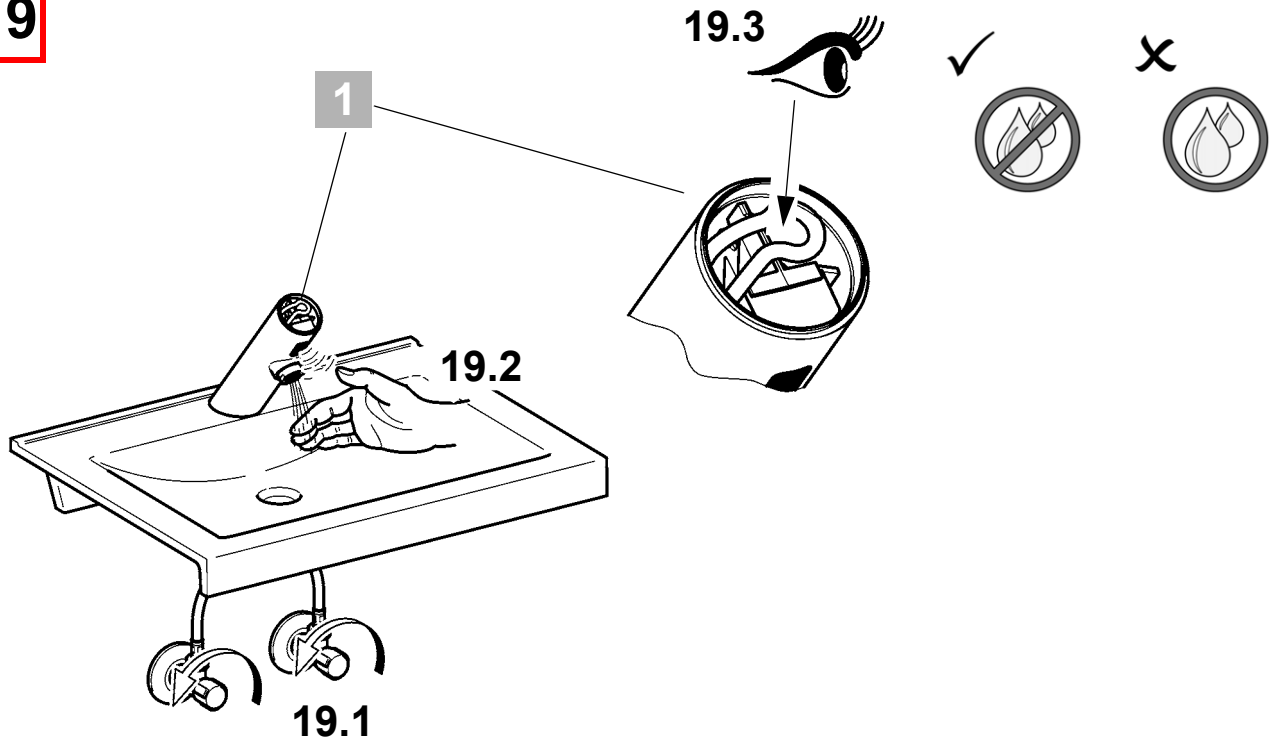

20

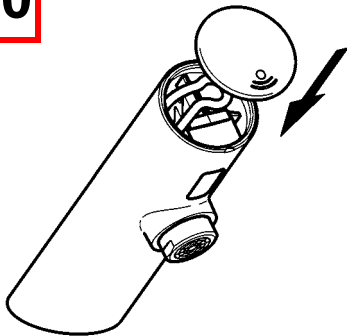

15. Magnetventilkartusche wechseln

EN Replacing the solenoid valve cartridge	NL Magneetventielpatroon verandering	CS Výměna kartuše s magnetickým ventilem
FR Remplacement de la cartouche d'électrovanne	PL Wymiana wkładu zaworu elektromagnetycznego	FI Magneettiventtiilipanoksen vaihtaminen
ES Cambiar cartucho de la válvula electromagnética	SV Byta magnetventilpatron	RU Замена картриджа электромагнитного клапана
IT Sostituzione della cartuccia della valvola elettromagnetica		

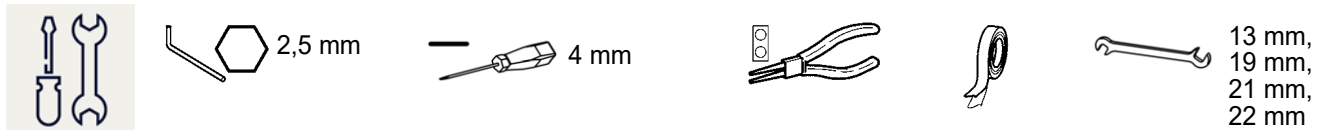

1

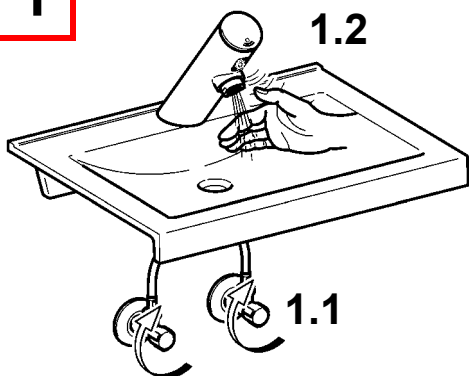

2

F3EM1001

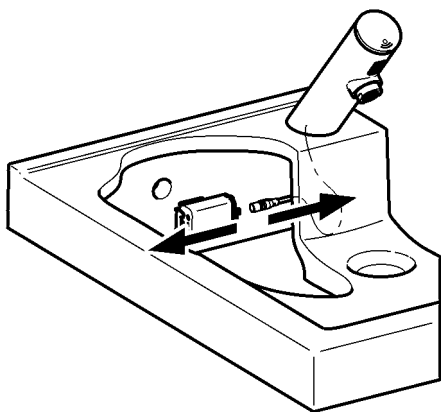

F3EM1002

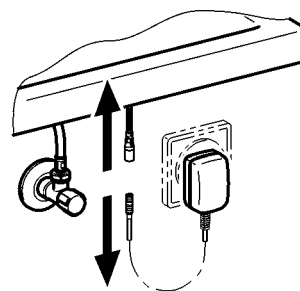

F3EM1003

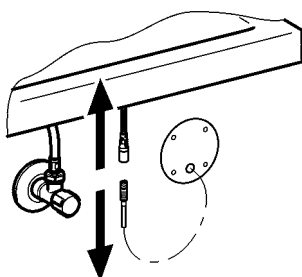

F3EM1005

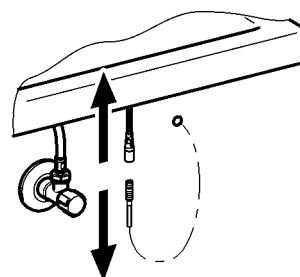

3

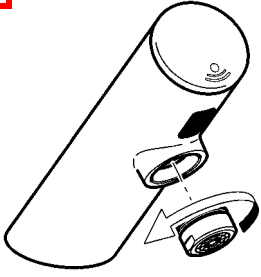

4

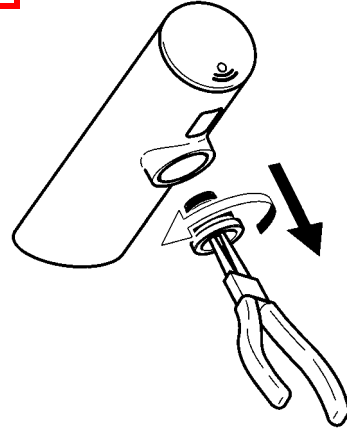

5

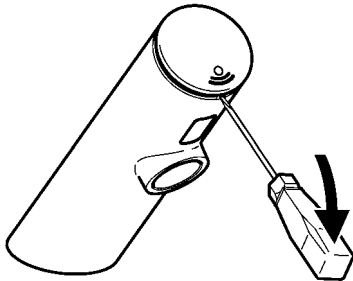

6

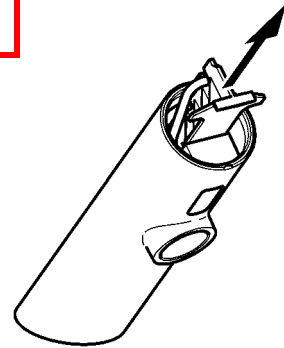

7

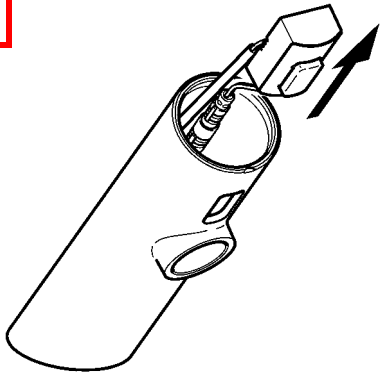

8

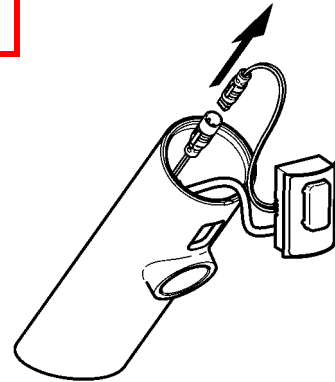

9

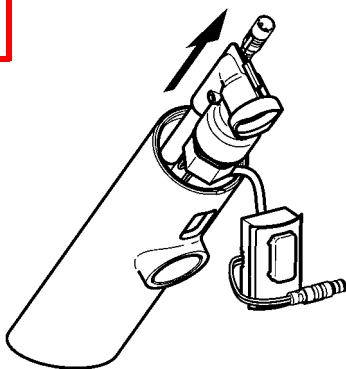

10

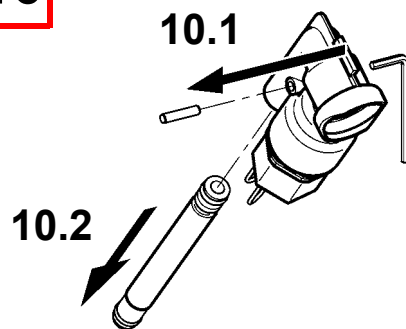

11

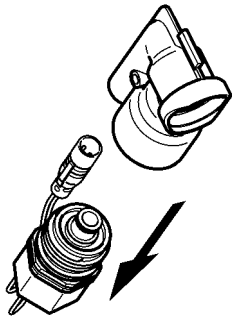

12

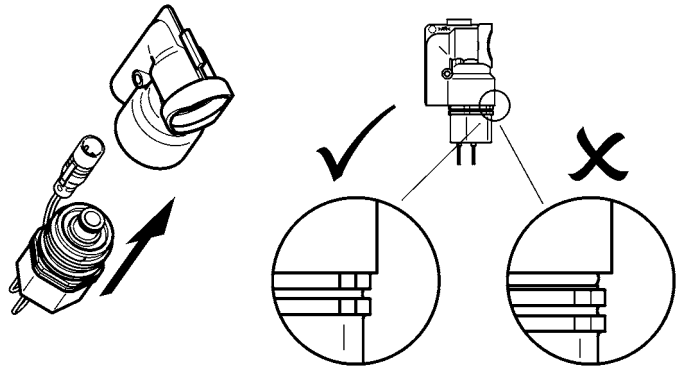

13

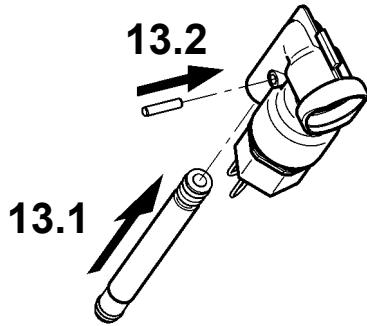

14

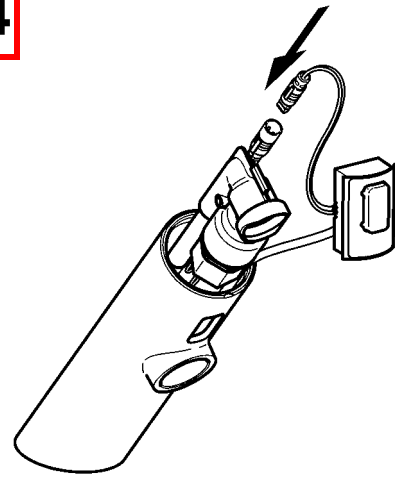

15

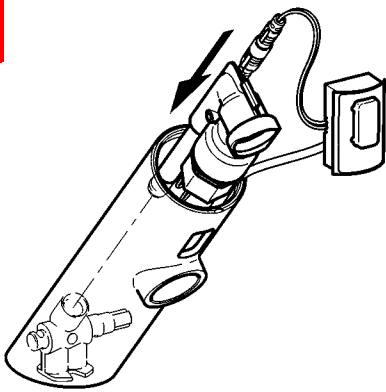

16

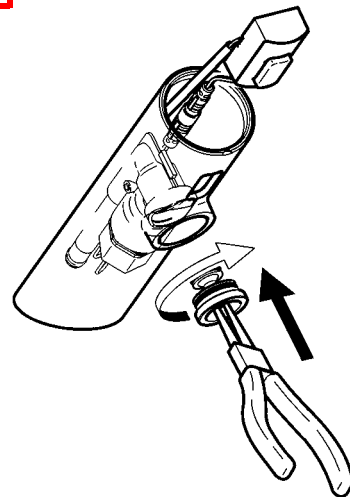

17

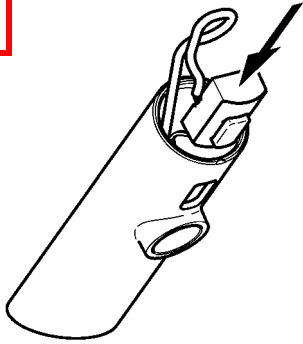

18

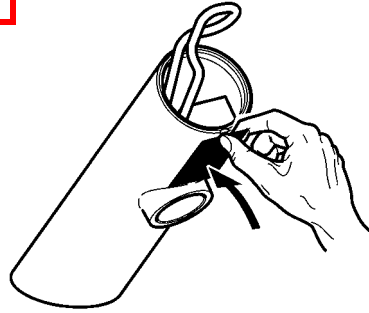

19

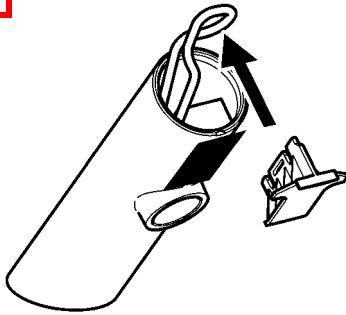

20

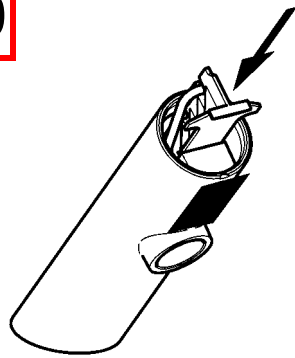

21

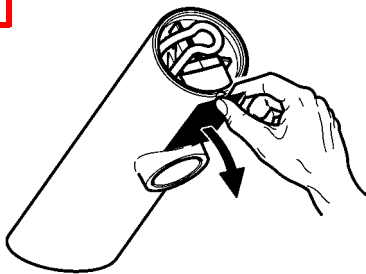

22

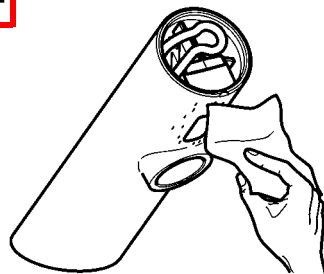

23

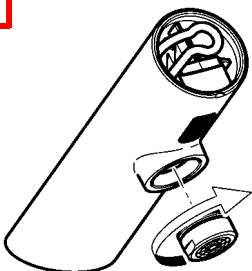

24

F3EM1001

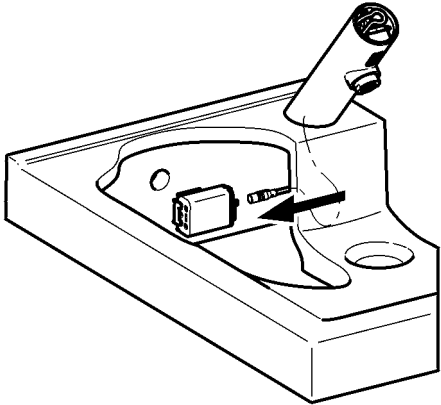

F3EM1002

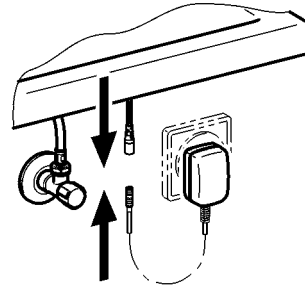

F3EM1003

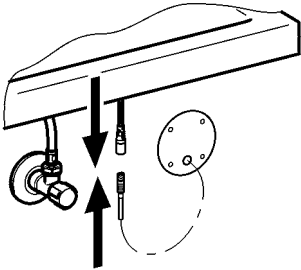

F3EM1005

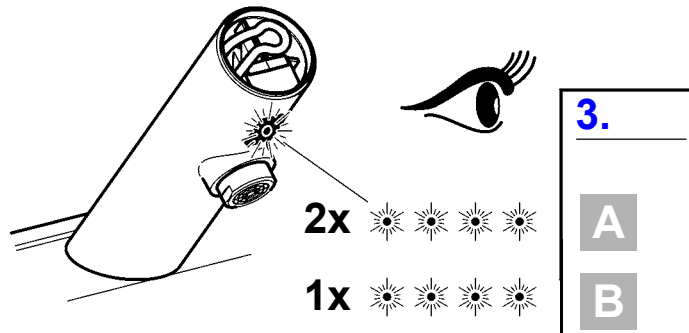
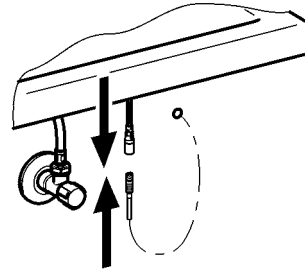

25

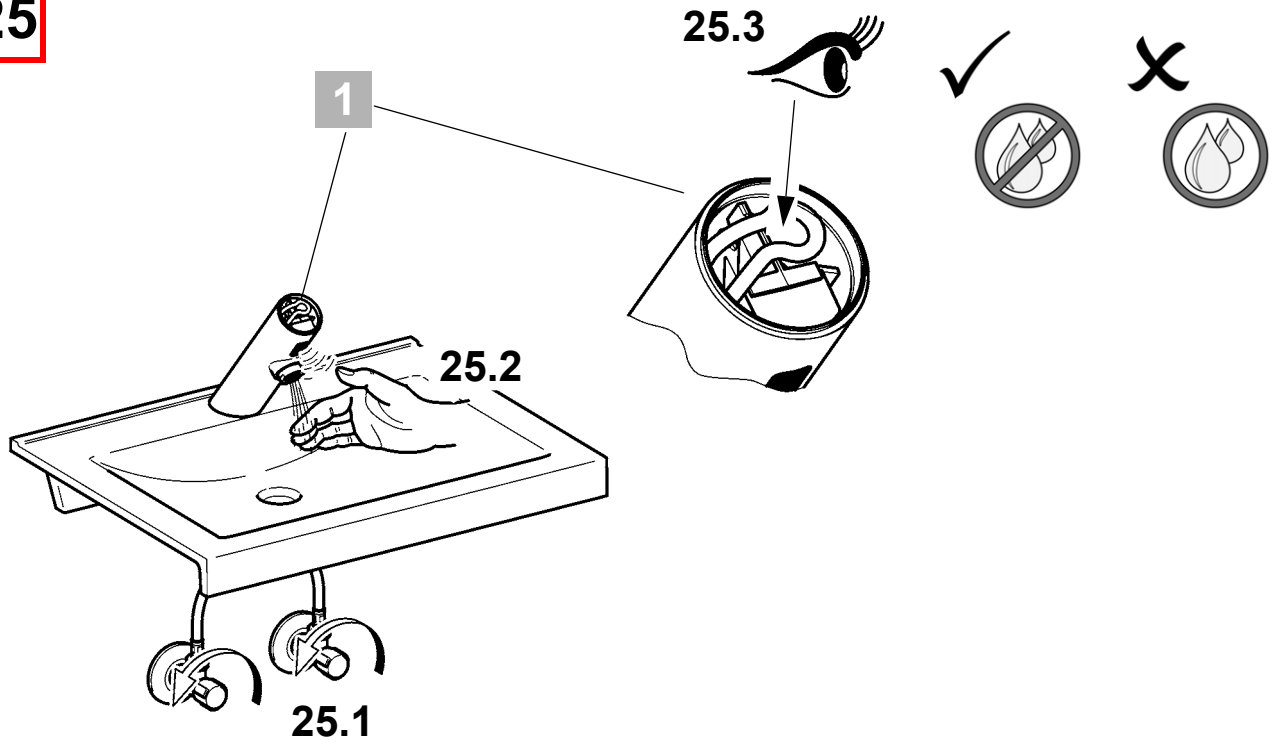

26

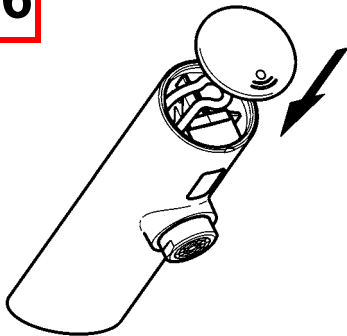

16. Batteriewechsel

EN Battery replacement
 FR Remplacement des piles
 ES Cambio de la pila
 IT Cambio delle batterie

NL Batterijen vervangen
 PL Wymiana baterii
 SV Batteribyte

CS Výměna baterie
 FI Paristonvaihto
 RU замена батареи

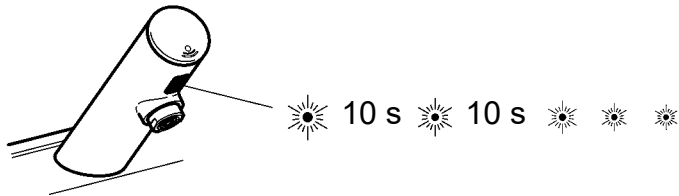

1

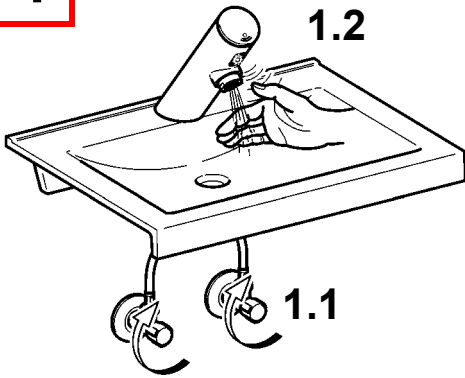

2

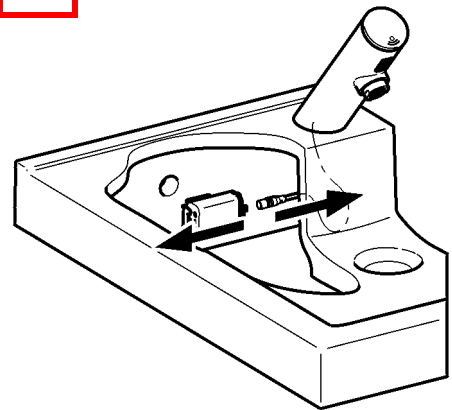

3

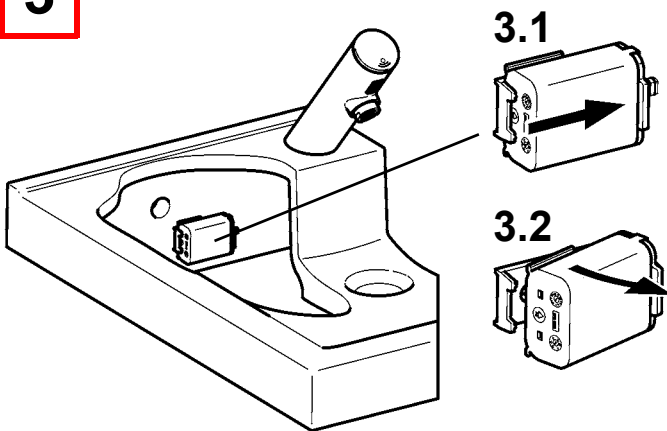

4

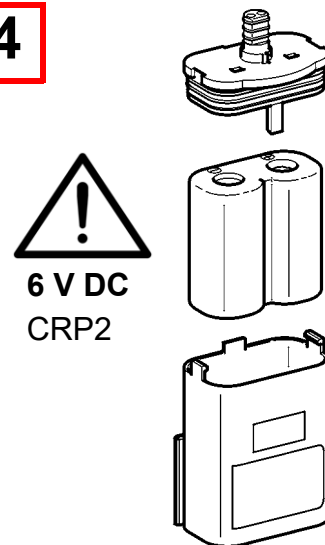

5

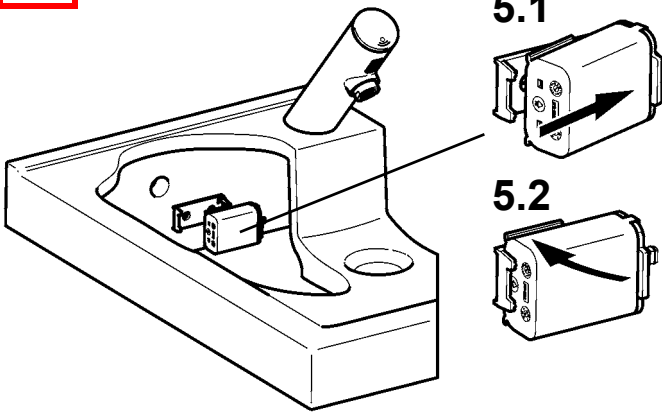

6

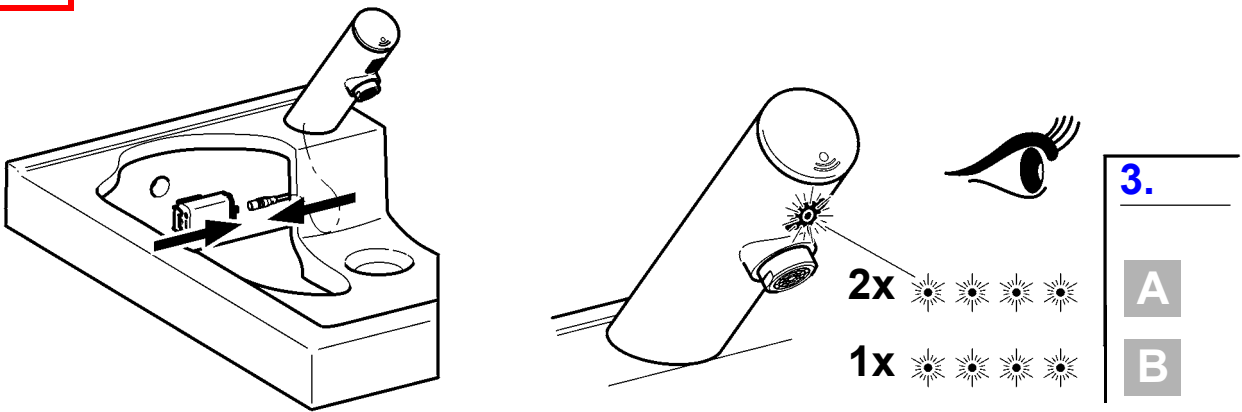

7

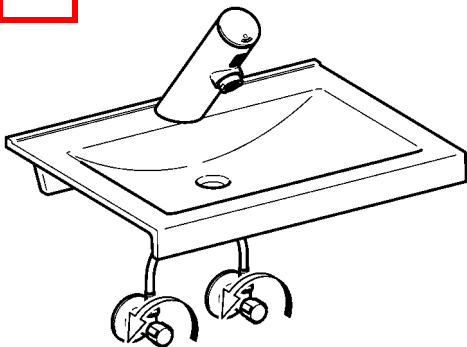

17. Ersatzteile

EN Replacement parts
FR Pièces de rechange
ES Piezas de recambio
IT Pezzi di ricambio

NL Reserveonderdelen
PL Części zamienne
SV Reservdelar

CS Náhradní díly
FI Varaosat
RU Запчасти

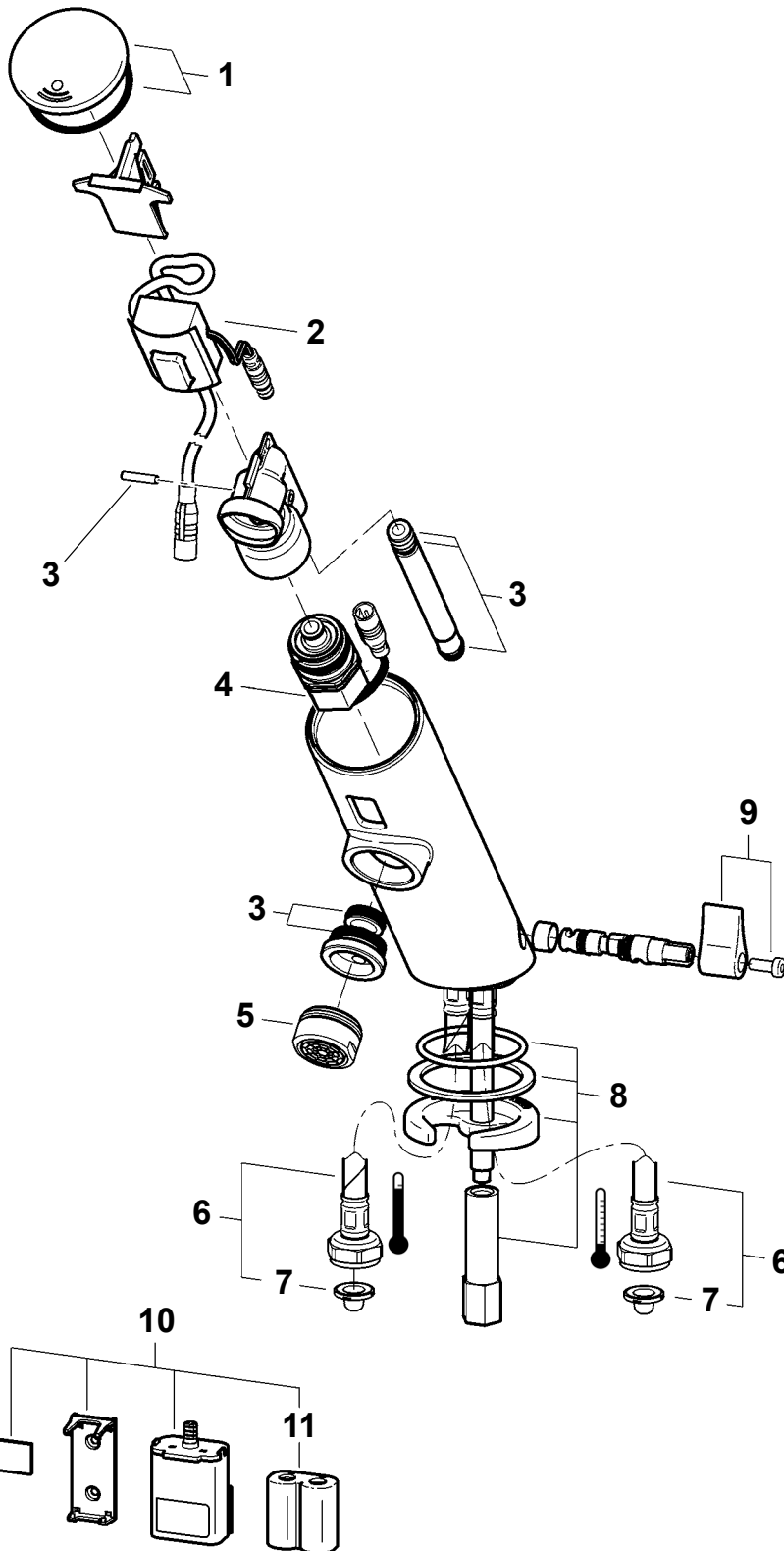

- 1..... 2030041514
ASEX1006
- 2..... 2030041447
ASEX1001
- 3..... 2030042426
ASEX1011
- 4..... 2030045522
ACXX9002
- 5..... 2000104691 a)
ASXX1015
- 6..... 2030041320
ASXM1001
- 7..... 2000104720 a)
- 8..... 2030042441
ASEX1012
- 9..... 2030042959
ASXM1004
- 10... 2000109466
ZAQCT0003
- 11... 2000104846
EPRTR0008
- 12... 2030039823
ACEX9002
- 13... 2030039825
ACEX9003

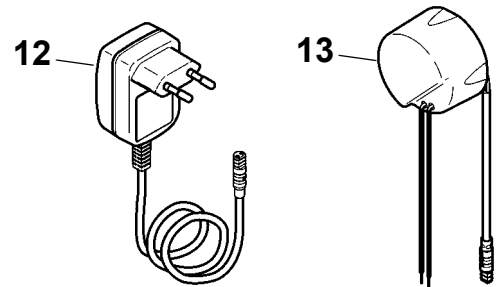

ZMI_001_2030034486_#SALL_#AQU_#V4.fm

EN a) 10 pieces	ES a) 10 piezas	PL a) 10 sztuk	FI a) 10 kappaletta
DE a) 10 Stück	IT a) 10 pezzi	SV a) 10 styck	RU a) 10 штук
FR a) 10 pièces	NL a) 10 stuk	CS a) 10 kusů	

18. Zubehör

EN Accessories
FR Accessoire
ES Accesorios
IT Accessori

NL Toebehoren
PL Akcesoria
SV Tillbehör

CS Příslušenství
FI Lisävarusteet
RU принадлежности

F3EM1001, F3EM1002, F3EM1003, F3EM1005

1



2



1..... 2030036654
ACEX9005

2..... 2030036849
ACEX9004

3

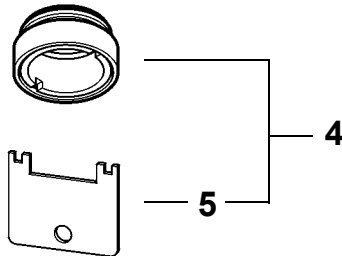
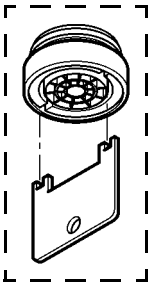

3..... **6 l/min:**
2000101160
ZAQUA087

4..... 2000104778
ZTAPS0005

5..... 2000105960
ZFITG0008

6

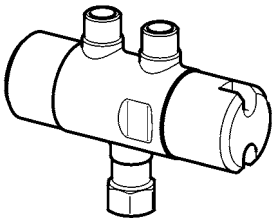

6..... 2030012758
PURE0031

7..... 2030039477
ACEX9001

8..... **5 m:**
2030043814
ACEX9010

F3EM1005

7

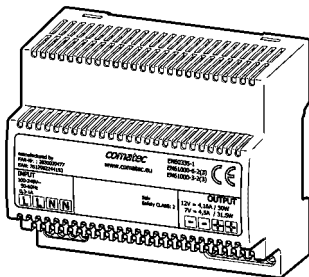

8

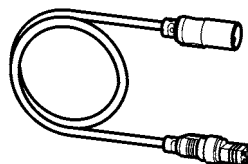

Notizen

EN Notes

FR Notes

ES Notas

IT Annotazioni

NL Notities

PL Uwagi

SV Notiser

CS Poznámky

FI Muistiinpanot

RU Примечания

Notizen

EN Notes

FR Notes

ES Notas

IT Annotazioni

NL Notities

PL Uwagi

SV Notiser

CS Poznámky

FI Muistiinpanot

RU Примечания

Notizen

EN Notes

FR Notes

ES Notas

IT Annotazioni

NL Notities

PL Uwagi

SV Notiser

CS Poznámky

FI Muistiinpanot

RU Примечания

Australia

PR Kitchen and
Water Systems Pty Ltd
Dandenong South VIC 3175
Phone +61 3 9700 9100

Austria

KWC Austria GmbH
6971 Hard, Austria
Phone +43 5574 6735 0

**Belgium, Netherlands &
Luxembourg**

KWC Aquarotter GmbH
9320 Aalst; Belgium
Phone +31 (0) 492 728 224

Czech Republic

KWC Aquarotter GmbH
14974 Ludwigsfelde, Germany
Phone +49 3378 818 309

France

KWC Austria GmbH
6971 Hard, Austria
Phone +33 800 909 216

Germany

KWC Aquarotter GmbH
14974 Ludwigsfelde
Phone +49 3378 818 0

Italy

KWC Austria GmbH
6971 Hard, Austria
Numero Verde +39 800 789 233

Middle East

KWC ME LLC Ras Al Khaimah,
United Arab Emirates
Phone +971 7 2034 700

Poland

KWC Aquarotter GmbH
14974 Ludwigsfelde, Germany
Phone +48 58 35 19 700

Spain

KWC Austria GmbH
6971 Hard, Austria
Phone +43 5574 6735 211

Switzerland & Liechtenstein

KWC Group AG
5726 Unterkulm, Switzerland
Phone +41 62 768 69 00

Turkey

KWC ME LLC Ras Al Khaimah,
United Arab Emirates
Phone +971 7 2034 700

United Kingdom

KWC DVS Ltd - Northern Office
Barlborough S43 4PZ
Phone +44 1246 450 255

KWC DVS Ltd - Southern Office
Paignton TQ4 7TW
Phone +44 1803 529 021

EAST EUROPE

Bosnia Herzegovina
Bulgaria | Croatia
Hungary | Latvia
Lithuania | Romania
Russia | Serbia | Slovakia
Slovenia | Ukraine

KWC Aquarotter GmbH
14974 Ludwigsfelde, Germany
Phone +49 3378 818 261

SCANDINAVIA & ESTONIA

Finland | Sweden | Norway
Denmark | Estonia

KWC Nordics Oy
76850 Naarajärvi, Finland
Phone +358 15 34 111

OTHER COUNTRIES

KWC Austria GmbH
6971 Hard, Austria
Phone +43 5574 6735 0

