

F3

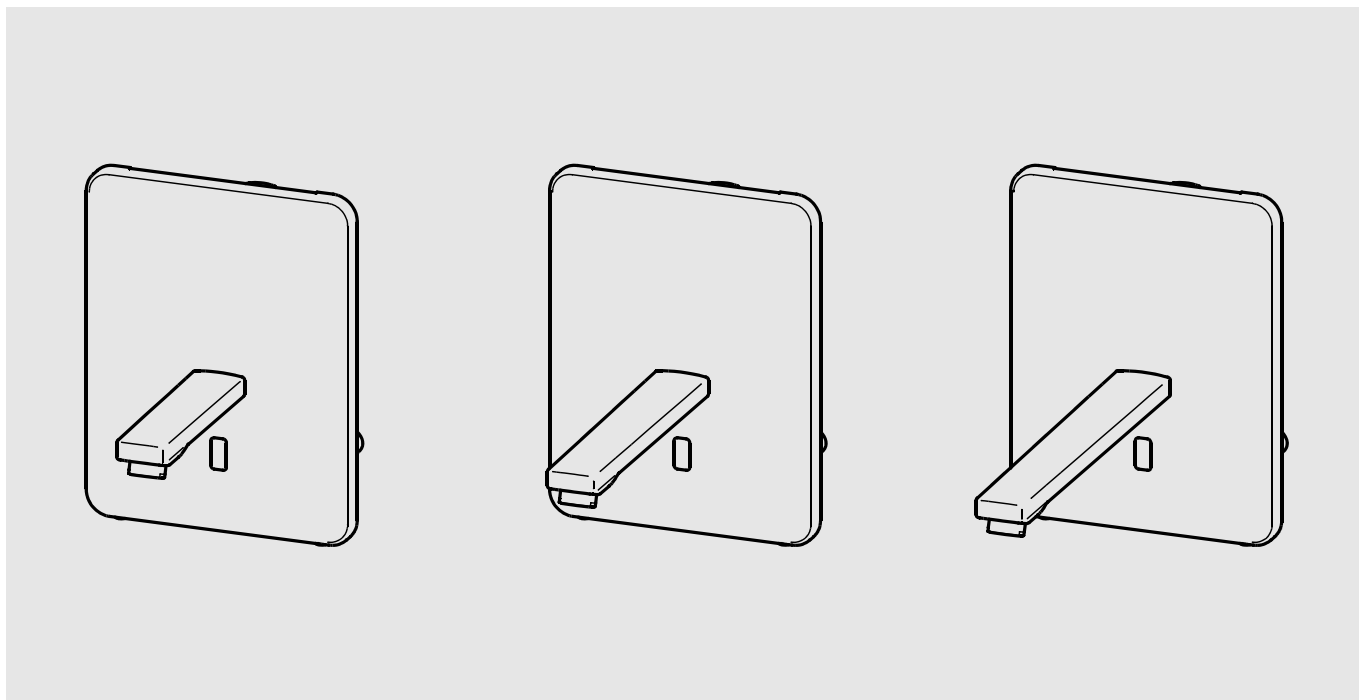

F3ET1010
2030040200

F3ET1011
2030040202

F3ET1012
2030040217

DE	Montage- und Betriebsanleitung	Elektronik-Thermostatbatterie
EN	Installation and operating instructions	Electronic thermostatic mixer
FR	Notice de montage et de mise en service	Mitigeur thermostatique électronique
ES	Instrucciones de montaje y servicio	Batería de termostato con sistema electrónico
IT	Istruzioni per il montaggio e l'uso	Miscelatore termostatico-elettronico
NL	Montage- en bedrijfsinstructies	Elektronische thermostaatmengkraan
PL	Instrukcja montażu i obsługi	
SV	Monterings- och driftinstruktion	
CS	Návod pro montáž a provoz	
FI	Asennus- ja käyttöohje	Elektroninen termostaattihana
RU	Инструкция по монтажу и вводу в эксплуатацию	



F3ET1010, F3ET1011, F3ET1012

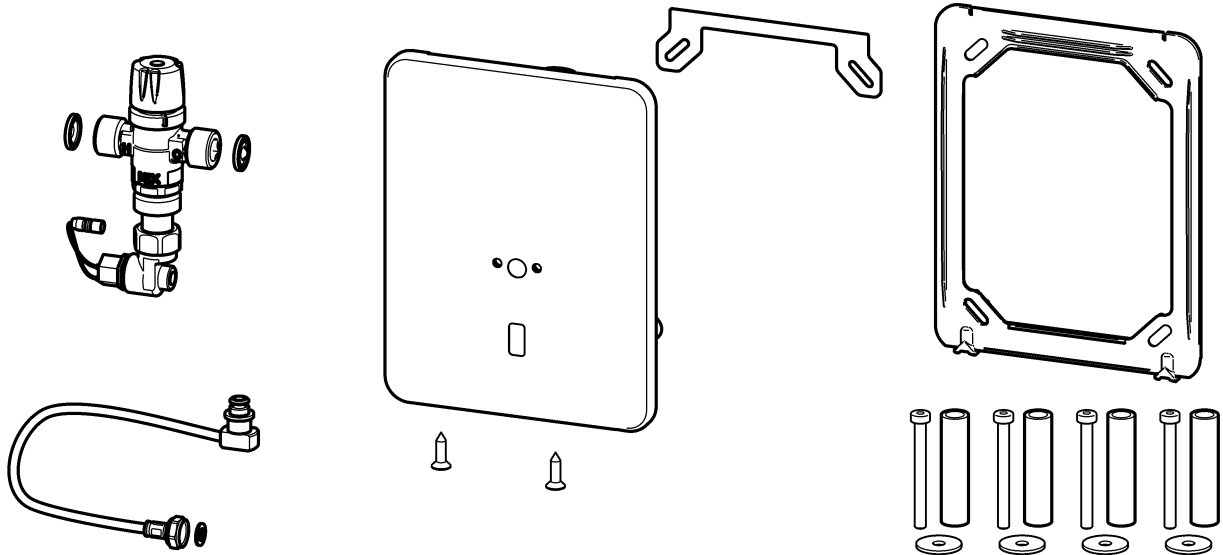

F3ET1010

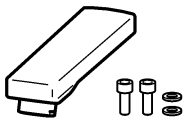

F3ET1011

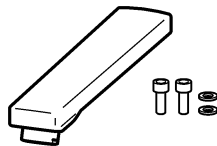

F3ET1012

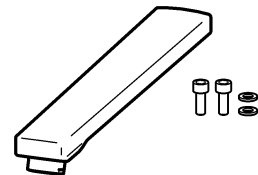

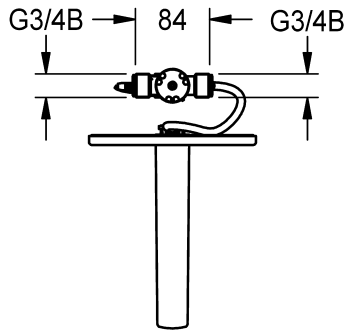
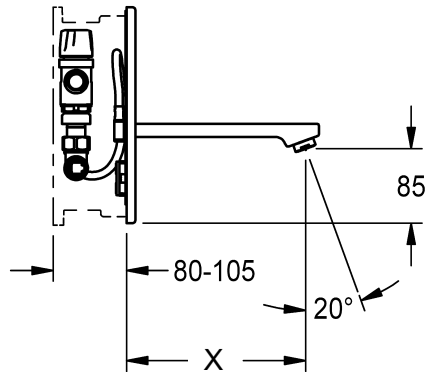
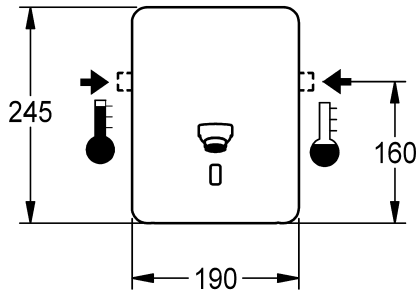

	X
F3ET1010	140
F3ET1011	200
F3ET1012	260

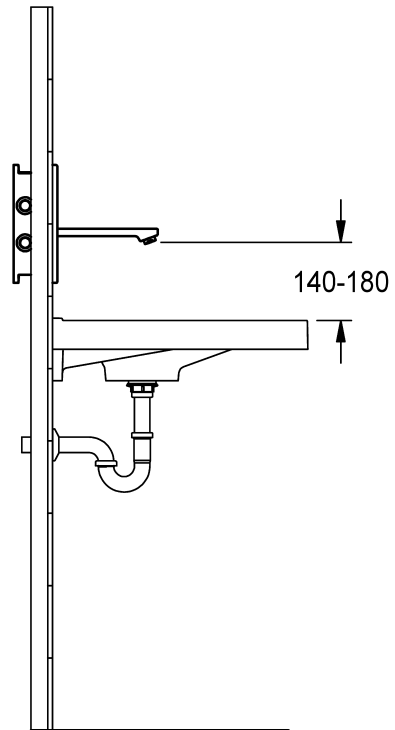
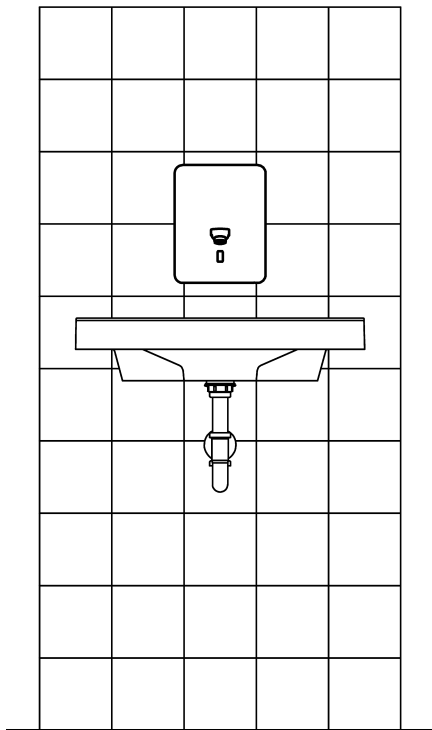

EN

Installation and operating instructions

Important notes

- ▶ All work must be carried out in a de-energised state.
- ▶ Before installing flush piping system!
- ▶ The fitting must be operated only with original mesh filters and return flow inhibitors!
- ▶ The fitting must be checked and maintained at regular intervals depending on the water quality and in accordance with the local conditions, and rules and regulations applicable at the site.

Technical data

- ▶ Minimum flow pressure 1.0 bar
- ▶ Maximum operating pressure 10 bar
- ▶ Recommended flow pressure 1-5 bar
- ▶ Volume flow at 3 bar flow pressure 6 l/min
- ▶ Thermostatic scald-protection in compliance with DIN EN 1111.
- ▶ Supply voltage 6.75 / 12 V DC
- ▶ Power consumption 1.5 W
- ▶ Type of protection IP 59k (in assembled condition)

PL

Instrukcja montażu i obsługi

Ważne wskazówki

- ▶ Wszystkie prace przeprowadzać po odłączeniu zasilania elektrycznego.
- ▶ Przed instalacją przepłukać rury!
- ▶ Po przeprowadzeniu montażu ustawić ograniczenie temperatury.
- ▶ Armatury należy używać wyłącznie z oryginalnymi siatkami i zaworami zwrotnymi!
- ▶ Armaturę należy poddawać regularnej kontroli i konserwacji w zależności od jakości wody, warunków lokalnych i obowiązujących przepisów.

DE

Montage- und Betriebsanleitung

Wichtige Hinweise

- ▶ Alle Arbeiten im spannungsfreien Zustand durchführen
- ▶ Vor Installation Rohrleitungen spülen!
- ▶ Armatur nur mit original Sieben und Rückflussverhinderern betreiben!
- ▶ In Abhängigkeit von der Wasserqualität, den örtlichen Gegebenheiten und den vor Ort geltenden Bestimmungen die Armatur in regelmäßigen Abständen prüfen und warten.

Technische Daten

- ▶ Mindestfließdruck 1,0 bar
- ▶ Maximaler Betriebsdruck 10 bar
- ▶ Empfohlener Fließdruck 1-5 bar
- ▶ Volumenstrom bei 3 bar Fließdruck 6 l/min
- ▶ Thermostatischer Verbrühungsschutz laut DIN EN 1111.
- ▶ Anschlussspannung 6,75 / 12 V DC
- ▶ Leistungsaufnahme 1,5 W
- ▶ Schutzart IP 59k (im zusammengebauten Zustand)

SV

Monterings- och driftinstruktion

Viktiga informationer

- ▶ Genomför alla arbeten i spänningslöst tillstånd.
- ▶ Spola igenom rörledningarna före installation!
- ▶ Ställ in temperaturstoppet efter installationen.
- ▶ Använd armaturen endast med originalsilar och originalåterflödesförhindrare!
- ▶ Kontrollera och serva armaturen med intervaller som bestäms av vattenkvaliteten samt de lokala förhållandena och de bestämmelser som gäller där.

Dane techniczne

- ▶ Minimalne ciśnienie przepływu 1,0 bar
- ▶ Maksymalne ciśnienie robocze 10 barów
- ▶ Zalecane ciśnienie przepływu 1-5 barów
- ▶ Objętościowe natężenie przepływu przy ciśnieniu 3 barów 6 l/min
- ▶ Termostatyczne zabezpieczenie przed poparzeniem zgodnie z DIN EN 1111.
- ▶ Napięcie przyłączeniowe 6,75 / 12 V DC
- ▶ Pobór mocy 1,5 W
- ▶ Rodzaj ochrony IP 59k (w zmontowanym stanie)

Tekniska data

- ▶ Minsta hydrauliska tryck 1,0 bar
- ▶ Maximalt driftryck 10 bar
- ▶ Rekommenderat hydrauliskt tryck 1-5 bar
- ▶ Volymstrom vid 3 bar hydrauliskt tryck 6 l/min
- ▶ Termostatiskt skällningskydd enligt DIN EN 1111.
- ▶ Anslutningsspänning 6,75 / 12 V DC
- ▶ Effektbehov 1,5 W
- ▶ Skyddsklass IP 59k (i hopsatt tillstånd)

FR

Notice de montage et de mise en service

Remarques importantes

- ▶ Effectuez tous les travaux quand le dispositif est hors tension.
- ▶ Rincer les conduites avant d'installer !
- ▶ Régler la butée de température après le montage.
- ▶ Ne faire fonctionner la robinetterie qu'avec les filtres et clapets de non retour d'origine !
- ▶ En fonction de la qualité de l'eau, ainsi que des conditions et des dispositions locales, il convient de contrôler et d'entretenir la robinetterie à intervalles réguliers.

Données techniques

- ▶ Pression dynamique minimale 1,0 bar
- ▶ Pression de service maximale 10 bars
- ▶ Pression dynamique recommandée 1-5 bars
- ▶ Débit volumique pour 3 bars de pression dynamique 6 l/min
- ▶ Protection thermostatique contre les échaudures selon DIN EN 1111.
- ▶ Tension de raccordement 6,75 / 12 V DC
- ▶ Puissance absorbée 1,5 W
- ▶ Type de protection IP 59k (à l'état assemblé)

CS

Návod pro montáž a provoz

Důležité pokyny

- ▶ Veškeré práce vykonávejte ve stavu bez napětí.
- ▶ Před instalací potrubí propláchněte!
- ▶ Po montáži nastavte teplotní limit.
- ▶ Provozovat armaturu jen s originálními sítky a zařízeními proti zpětnému toku!
- ▶ V závislosti na kvalitě vody, místních podmínkách a předpisech platných v místě instalace je nutné provádět v pravidelných intervalech kontrolu a údržbu armatury.

Technické údaje

- ▶ Minimální průtočný tlak 1,0 bar
- ▶ Maximální provozní tlak 10 bar
- ▶ Doporučený průtočný tlak 1-5 bar
- ▶ Průtok při průtočném tlaku 3 bar 6l/min
- ▶ Termostatická ochrana proti opažení podle normy DIN EN 1111.
- ▶ Přípojné napětí 6,75 / 12 V DC
- ▶ Příkon 1,5 W
- ▶ Krytí IP 59k (ve smontovaném stavu)

ES

Instrucciones de montaje y servicio

Indicaciones importantes

- ▶ Todos los trabajos deben realizarse con la tensión de alimentación desconectada.
- ▶ ¡Enjuagar las tuberías antes de instalar!
- ▶ Tras finalizar el montaje, ajustar el tope de temperatura.
- ▶ ¡La grifería debe hacerse funcionar únicamente con los tamices y las válvulas antiretorno originales!
- ▶ En función de la calidad del agua, las condiciones locales y la legislación vigente, realizar las inspecciones y el mantenimiento de la grifería a intervalos regulares.

Datos técnicos

- ▶ Presión mínima de flujo 1,0 bar
- ▶ Presión máxima de servicio 10 bares
- ▶ Presión de flujo recomendada 1-5 bares
- ▶ Flujo volumétrico con 3 bares de presión de flujo 6 l/min
- ▶ Protección termostática frente a escaldaduras según DIN EN 1111.
- ▶ Tensión de conexión 6,75 / 12 V DC
- ▶ Consumo de potencia 1,5 W
- ▶ Modo de protección IP 59k (en estado montado)

IT

Istruzioni per il montaggio e l'uso

Avvertenze importanti

- ▶ Eseguire tutti i lavori fuori tensione.
- ▶ Sciacquare le tubazioni prima di installare!
- ▶ A montaggio avvenuto impostare il blocco temperatura.
- ▶ Utilizzare la rubinetteria esclusivamente con i filtri e le valvole antiriflusso originali!
- ▶ Controllare e sottoporre a manutenzione l'apparecchio ad intervalli regolari, in funzione della qualità dell'acqua, delle caratteristiche locali e delle vigenti disposizioni locali.

FI

Asennus- ja käyttöohje

Tärkeitä ohjeita

- ▶ Kaikki työt on tehtävä jännitteettömälle järjestelmälle.
- ▶ Huuhtelee putkijohdot ennen asennusta!
- ▶ Kun asennus on tehty, säädä lämpötilarajoin.
- ▶ Käytä varusteet vain alkuperäisten sihtien ja takaisinvirtauksen eston kanssa!
- ▶ Hana tulee tarkistaa ja huoltaa säännöllisin väliajoin veden laadusta, paikallisista oloista ja paikalla voimassa olevista määräyksistä riippuen.

Tekniset tiedot

- ▶ Vähimmäisvirtauspaine 1,0 bar
- ▶ Suurin käyttöpaine 10 bar
- ▶ Suositeltava virtauspaine 1-5 bar
- ▶ Tilavuusvirta 3 barin virtauspaineella 6 l/min
- ▶ Termostaattinen kuumavesisuoja DIN EN 1111 mukaan
- ▶ Verkkojännite 6,75 / 12 V DC
- ▶ Tehonkulutus 1,5 W
- ▶ Suojaustapa IP 59k (kootussa tilassa)

RU

Инструкция по монтажу и вводу в эксплуатацию

Важные указания

- ▶ Выполняйте все работы при отключенном напряжении.
- ▶ Перед инсталляцией промыть трубки!
- ▶ После произведенного монтажа настроить температурный упор.
- ▶ Эксплуатировать арматуру только с оригинальными фильтрами и клапанами обратного течения!
- ▶ Арматуру необходимо регулярно чистить и обслуживать в зависимости от качества воды, местных условий и действующих в месте эксплуатации предписаний.

Specifiche tecniche

- ▶ Pressione idraulica min. 1,0 bar
- ▶ Pressione di esercizio max. 10 bar
- ▶ Pressione idraulica consigliata 1-5 bar
- ▶ Portata volumetrica a 3 bar di pressione idraulica 6 l/min
- ▶ Protezione antiscottatura termostatica secondo DIN EN 1111.
- ▶ Tensione di allacciamento 6,75 / 12 V DC
- ▶ Potenza assorbita 1,5 W
- ▶ Tipo di protezione IP 59k (Nello stato montato)

Технические характеристики

- ▶ Минимальный гидравлический напор 1,0 бар
- ▶ Максимальное рабочее давление 10 бар
- ▶ Рекомендуемый гидравлический напор 1-5 бар
- ▶ Объёмный расход при гидравлическом напоре 3 бар 6 л/мин
- ▶ Термостатическая система защиты от ожога горячим паром/жидкостью согласно стандарту DIN EN 1111.
- ▶ Напряжение питающей сети 6,75 / 12 В постоянного тока
- ▶ Потребляемая мощность 1,5 Вт
- ▶ Вид защиты IP 59k (в собранном состоянии)

NL

Montage- en bedrijfsinstructies

Belangrijke aanwijzingen

- ▶ Alle werkzaamheden in spanningsloze toestand uitvoeren.
- ▶ Voor installatie buisleidingen spoelen!
- ▶ Na de montage de temperatuurbegrenzing instellen.
- ▶ Na de montage de temperatuurbegrenzing instellen!
- ▶ Armatuur alleen met originele zeven en terugstroomkleppen gebruiken!
- ▶ Afhankelijk van de waterkwaliteit, de plaatselijke omstandigheden en de plaatselijke voorschriften de armatuur regelmatig controleren en onderhouden.

Technische gegevens

- ▶ Minimale dynamische druk 1,0 bar
- ▶ Maximale werkdruk 10 bar
- ▶ Aanbevolen dynamische druk 1-5 bar
- ▶ Volumestroom bij 3 bar dynamische druk 6 l/min
- ▶ Thermostatische beveiliging tegen verbranding volgens DIN EN 1111.
- ▶ Aansluitspanning 6,75 / 12 V DC
- ▶ Opgenomen vermogen 1,5 W
- ▶ Veiligheidsgraad IP 59k (in gemonteerde toestand)

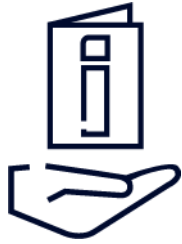
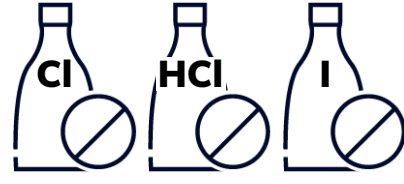

1. Montage

EN Installation
FR Montage
ES Montaje
IT Montaggio

NL Montage
PL Montaż
SV Montering

CS Montáž
FI Asennus
RU Монтаж



19 mm
30 mm

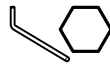

3 mm
5 mm

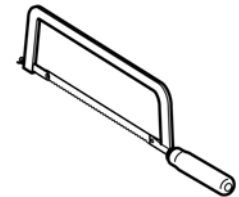
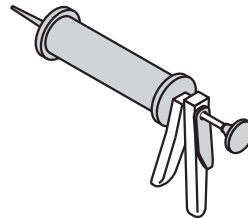
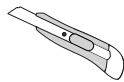
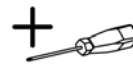

1

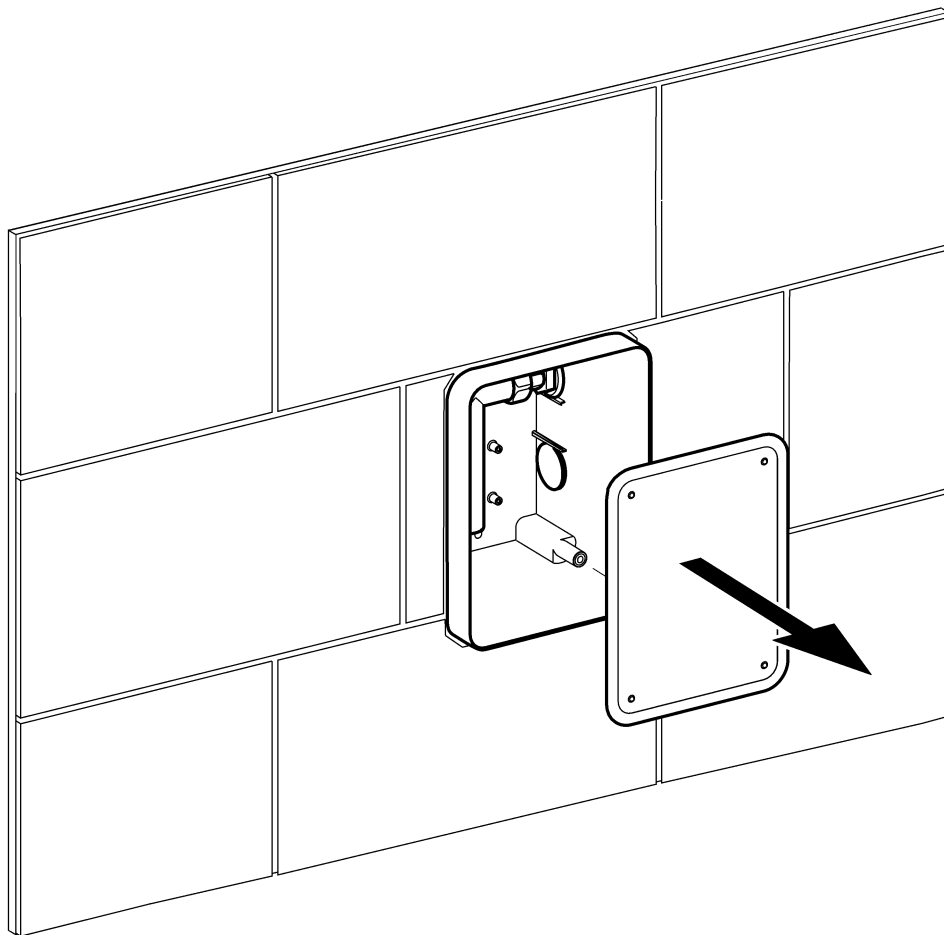

2

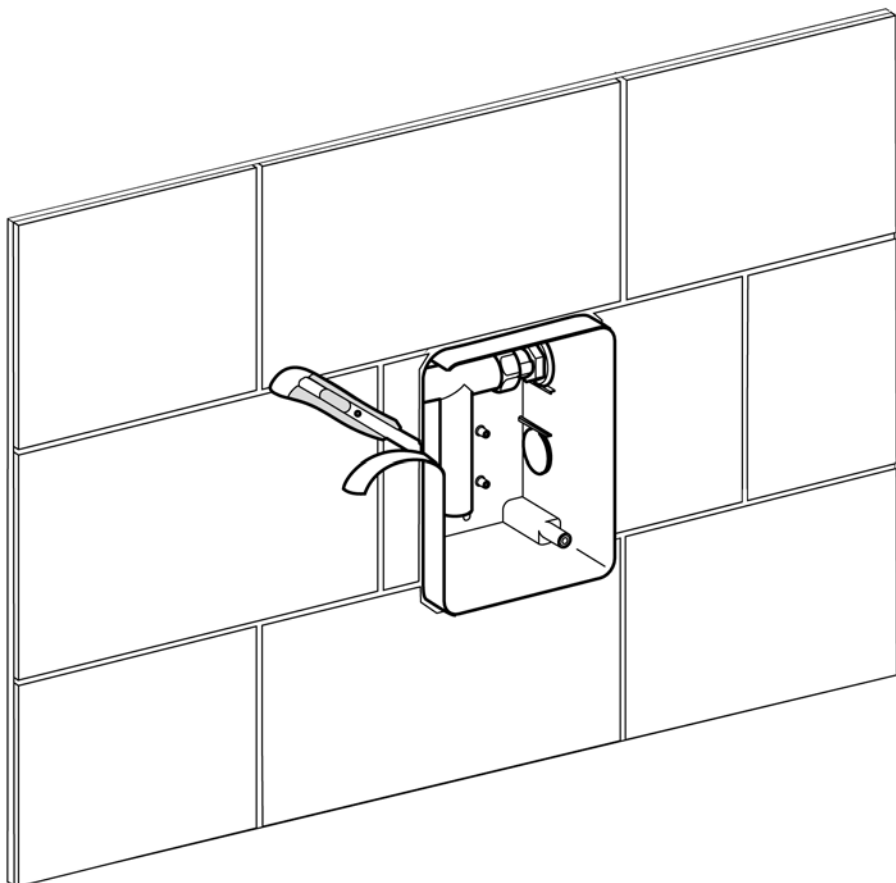

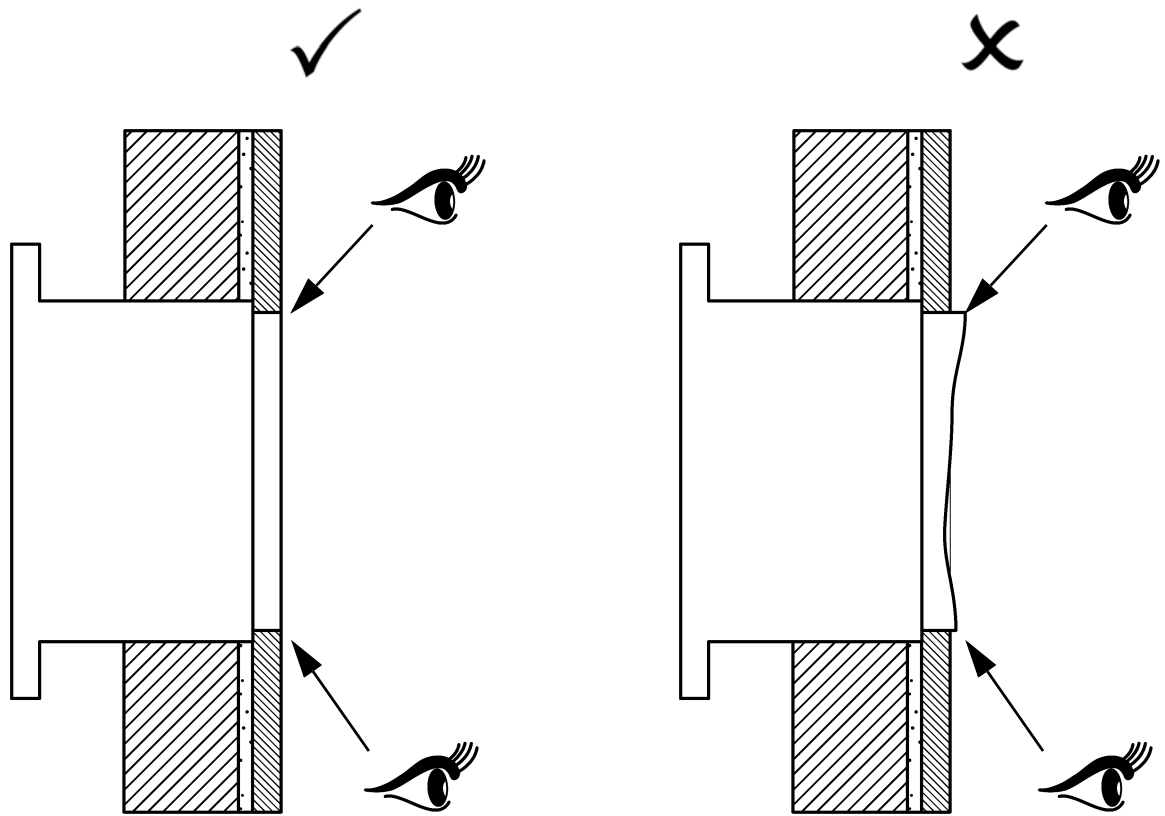

3

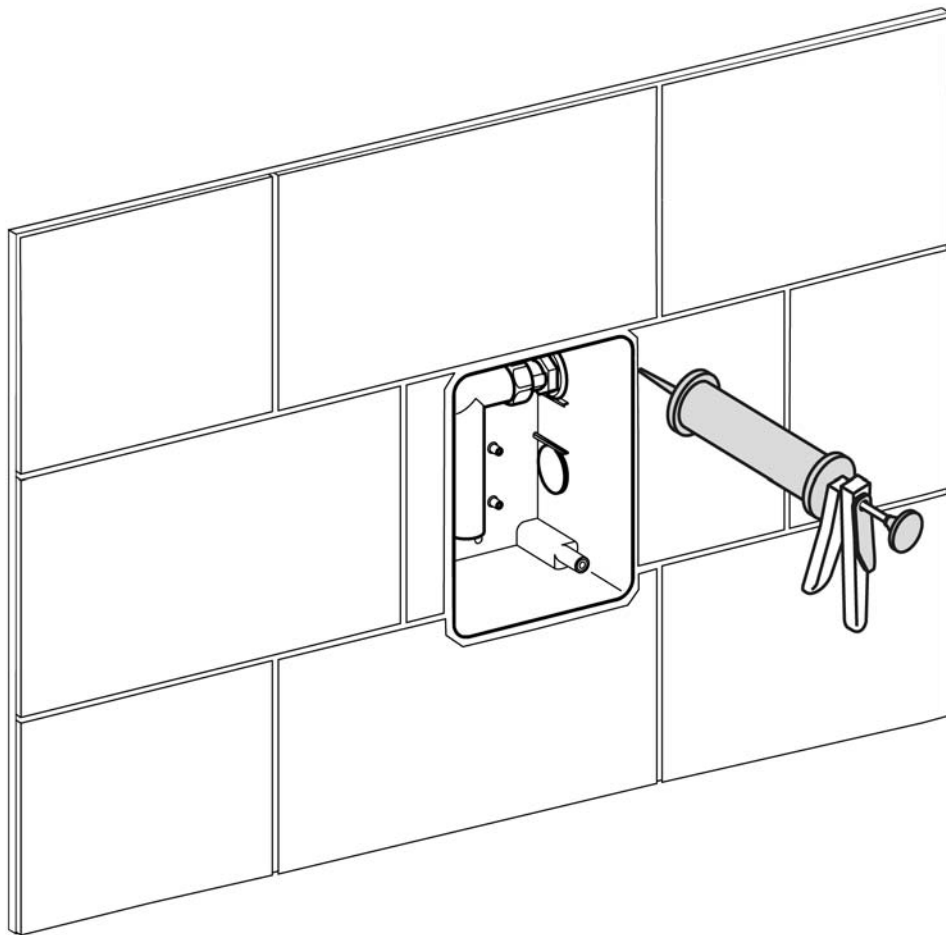

4

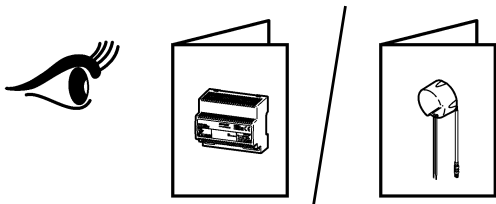
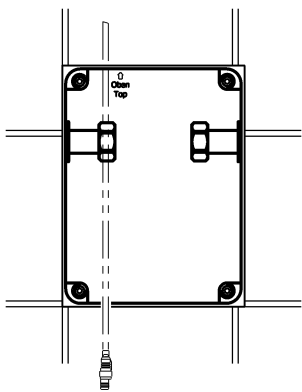

5

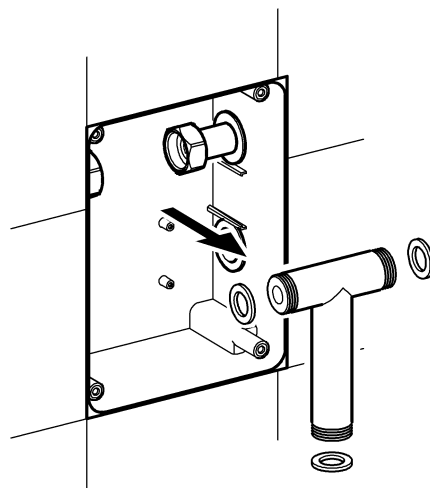

6

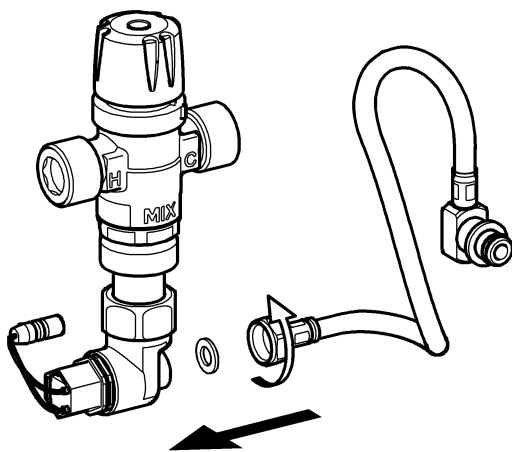

7

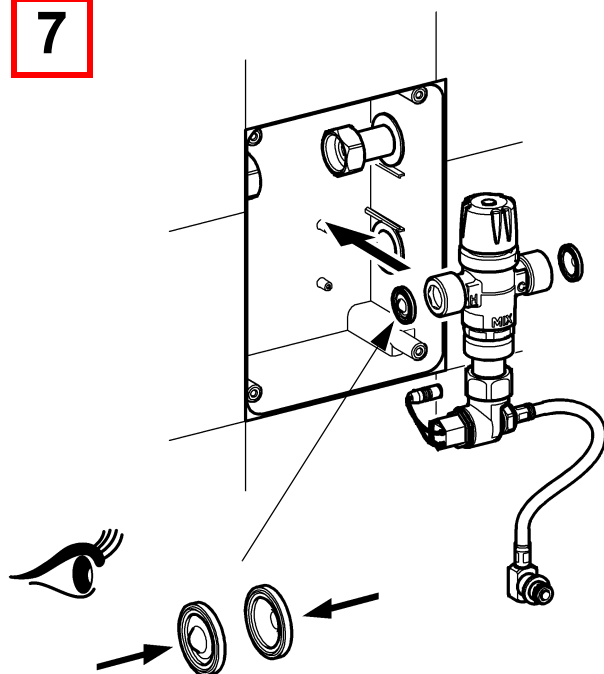

8

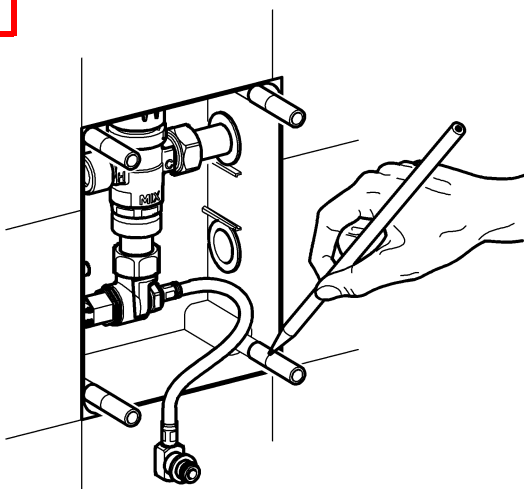

9

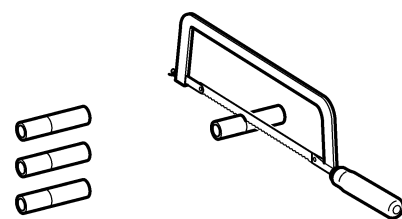

10

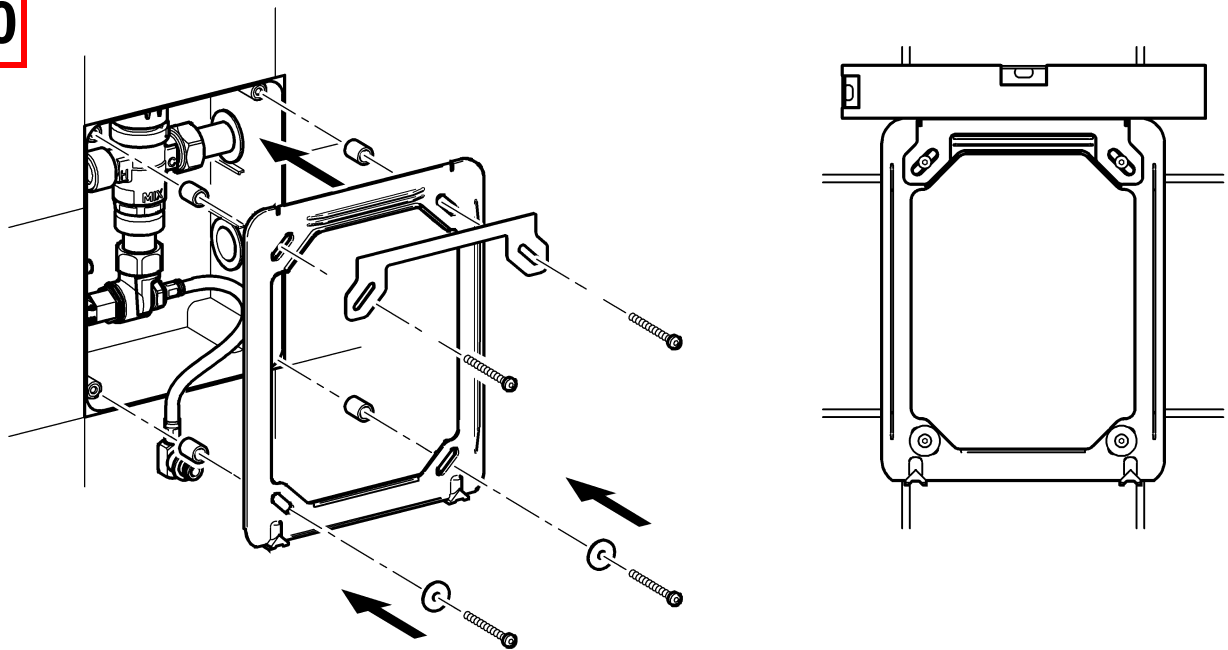

11

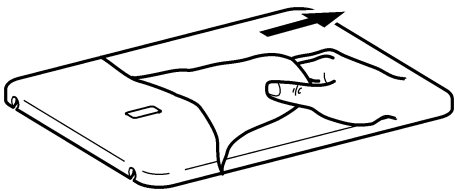

12

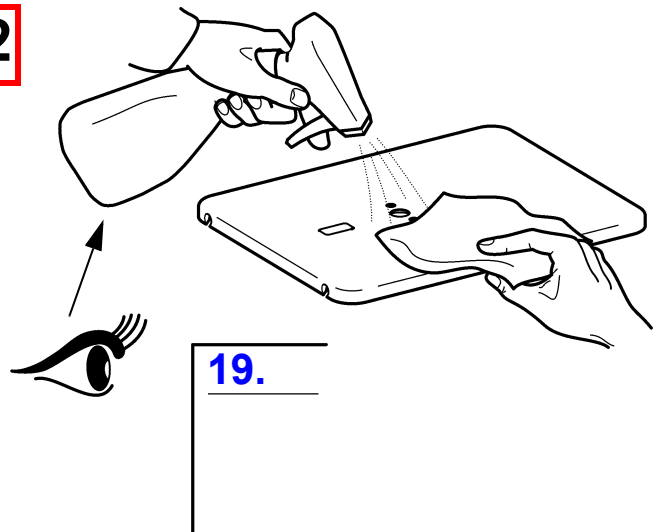

13

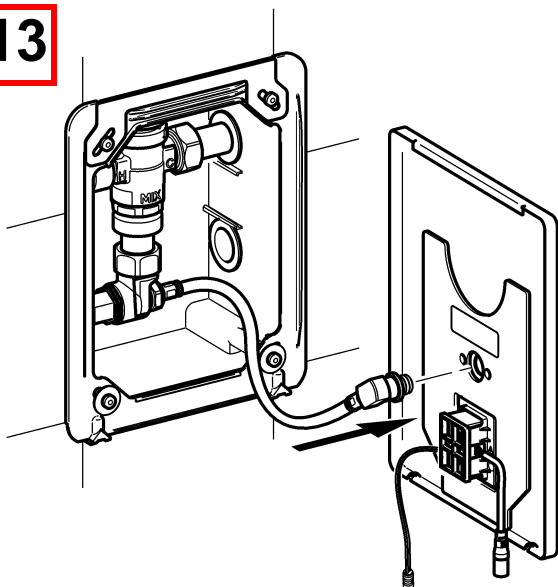

14

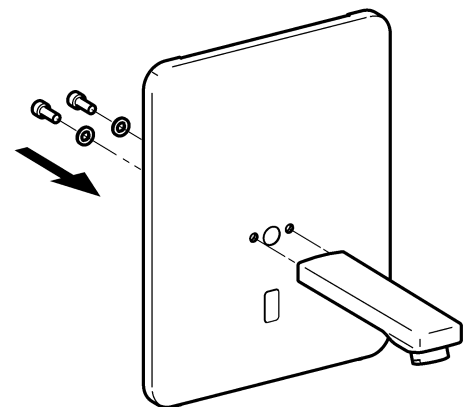

15

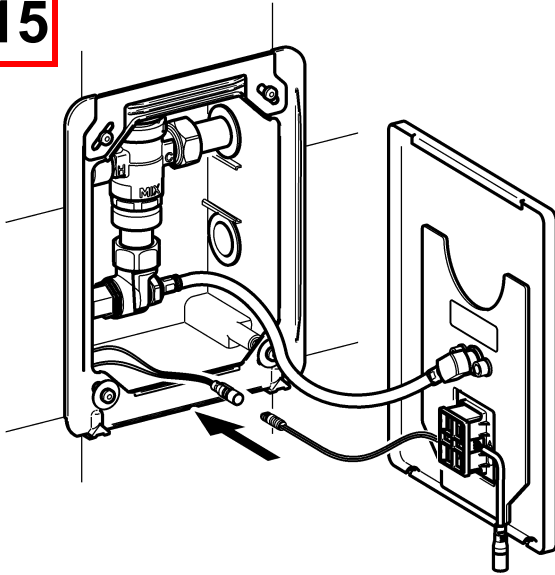

16

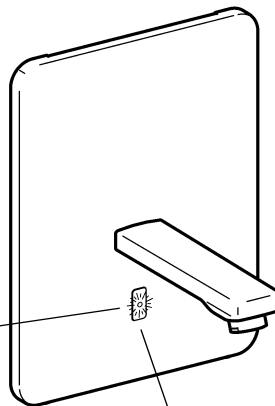
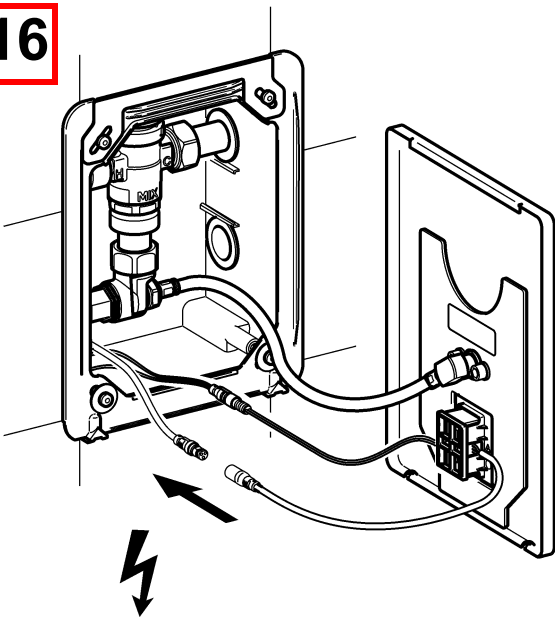

3.

A 2x    

A

B 1x    

B

17

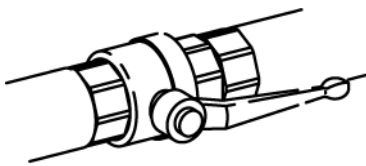

18

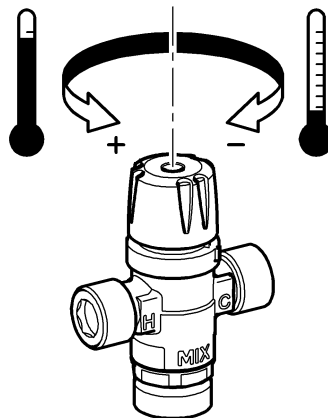

19

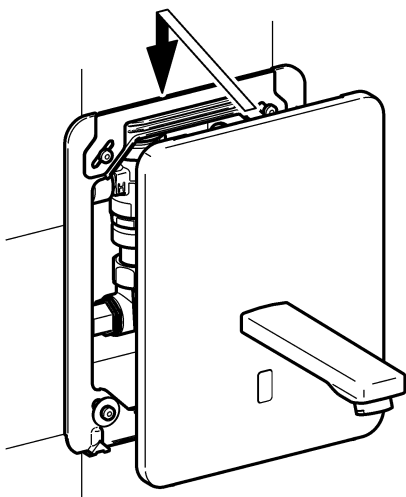

20

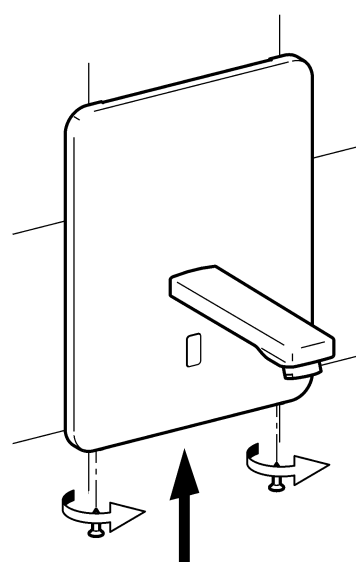

2. Funktion

EN Function

FR Fonctionnement

ES Función

IT Funzionamento

NL Werking

PL Funkcja

SV Funktion

CS Funkce

FI Toiminto

RU Функционирование

1

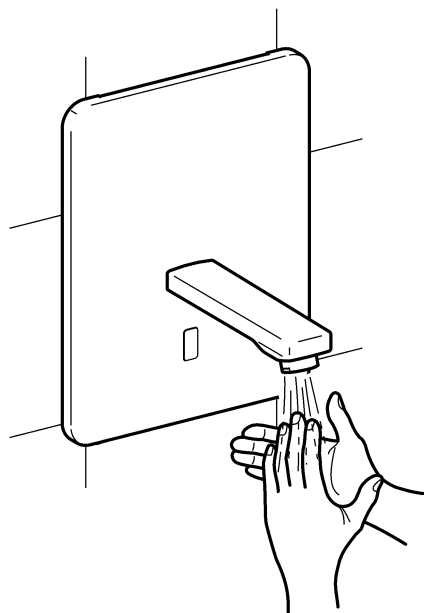

2

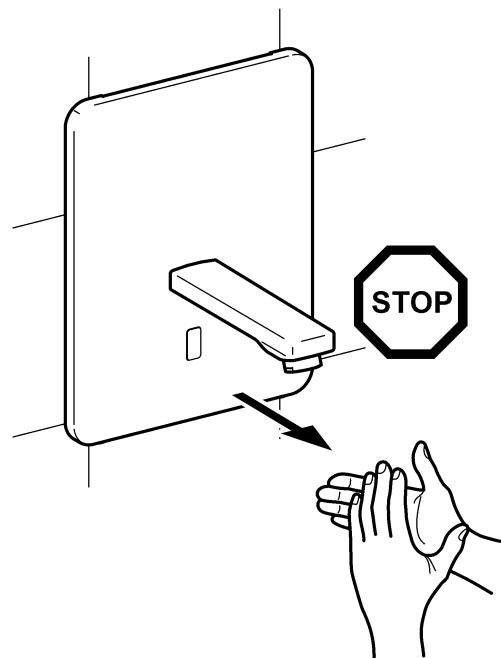

3. Hygienspülung ein- / ausschalten

EN Switching hygiene flushing on/off	NL Hygiënische spoeling in-/uitschakelen	CS Zapněte/vypněte hygienické propláchnutí
FR Activer/désactiver le rinçage hygiénique	PL Włączyć/wyłączyć spłukiwanie higieniczne	FI HygieniahuuhTELun päälle-/ pois päältä kytkeminen
ES Activar/Desactivar el aclarado higiénico	SV Koppla hygienspolningen till / från	RU Гигиеническое промывание включить/выключить
IT Attivare/disattivare lo sciacquo igienico		

- EN**
- ▶ Ensure open outlet.
 - ▶ After 24h of non-use, water flows 30 s
- DE**
- ▶ Freien Auslauf gewährleisten.
 - ▶ Nach 24 h Nichtbenutzung fließt 30 s Wasser.
- FR**
- ▶ Garantir un écoulement libre.
 - ▶ L'eau s'écoule pendant 30 s. après 24 h de non utilisation.
- ES**
- ▶ Garantizar una salida libre.
 - ▶ Si no se realiza ningún uso durante 24 horas, fluye agua durante 30 segundos.
- IT**
- ▶ Garantire l'erogazione libera.
 - ▶ Dopo 24h di inutilizzo scorre acqua per 30 s.
- NL**
- ▶ Vrije uitloop garanderen.
 - ▶ Na 24 uur niet te zijn gebruikt stroomt er gedurende 30 s. water.
- PL**
- ▶ Zapewnić swobodny wylot.
 - ▶ Po 24 godz. niekorzystania przez 30 s. wypływa woda.
- SV**
- ▶ Garantera fritt avlopp.
 - ▶ Vatten flyter 30 s efter 24 timmars användningspaus.
- CS**
- ▶ Zajistěte volný odtok.
 - ▶ Při nepoužívání 24 h nechte 30 s téct vodu.
- FI**
- ▶ Vapaan virtauksen takaaminen.
 - ▶ Käyttämättömänä 24 h jälkeen virtaa vettä 30 s.
- RU**
- ▶ Обеспечить беспрепятственный слив
 - ▶ После того, как устройство не используется в течение 24 ч, в течение 30 сек течёт вода.

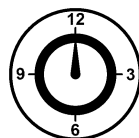
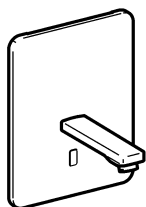

24 h

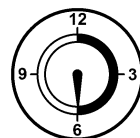
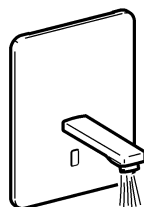

30 s

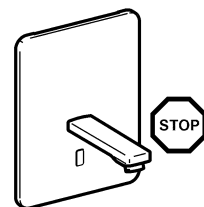

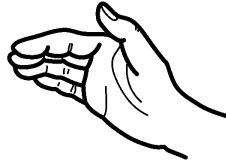
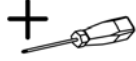

1

8

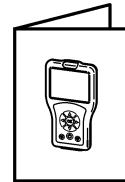
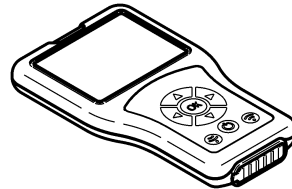
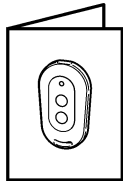

1

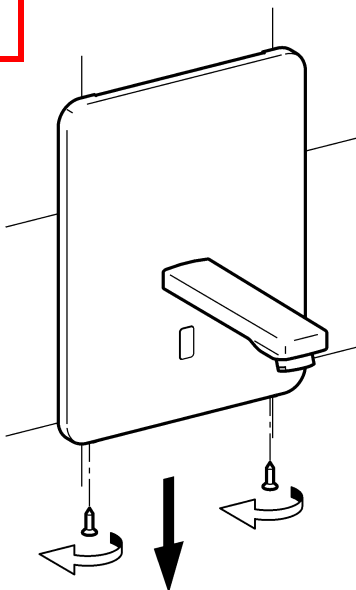

2

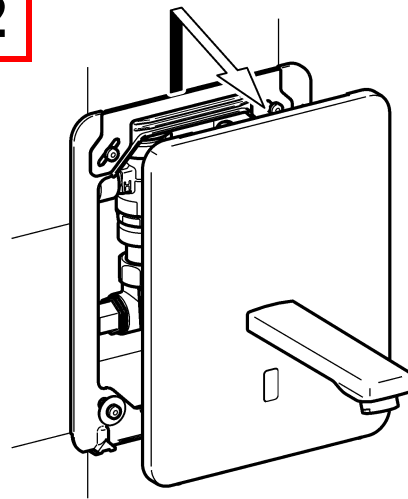

3

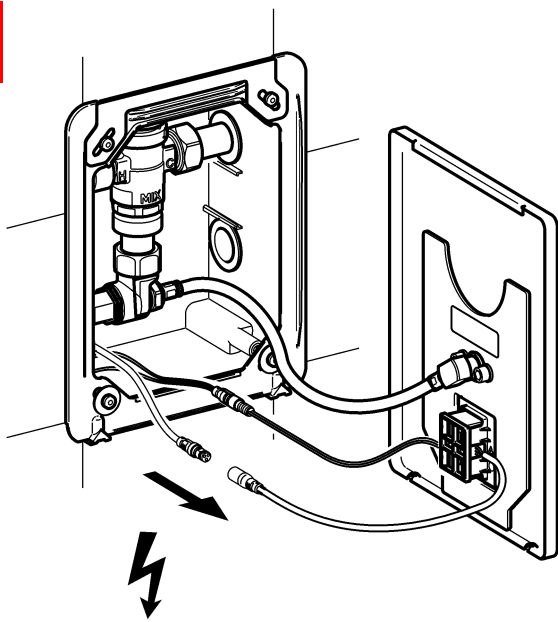

4

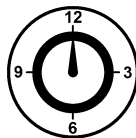

60 s

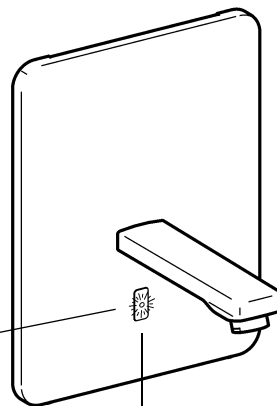
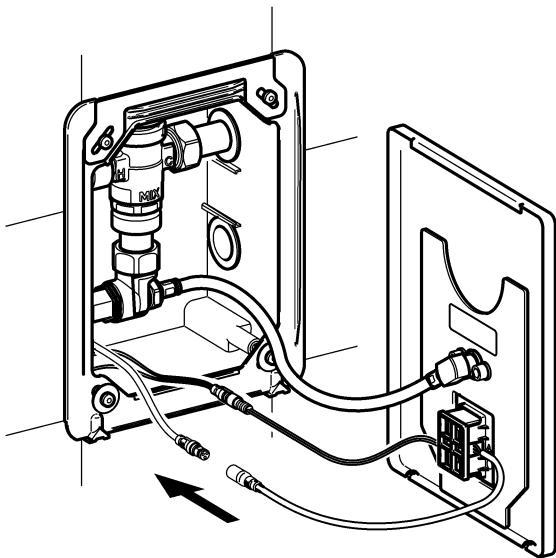

A 2x 

B 1x 

A

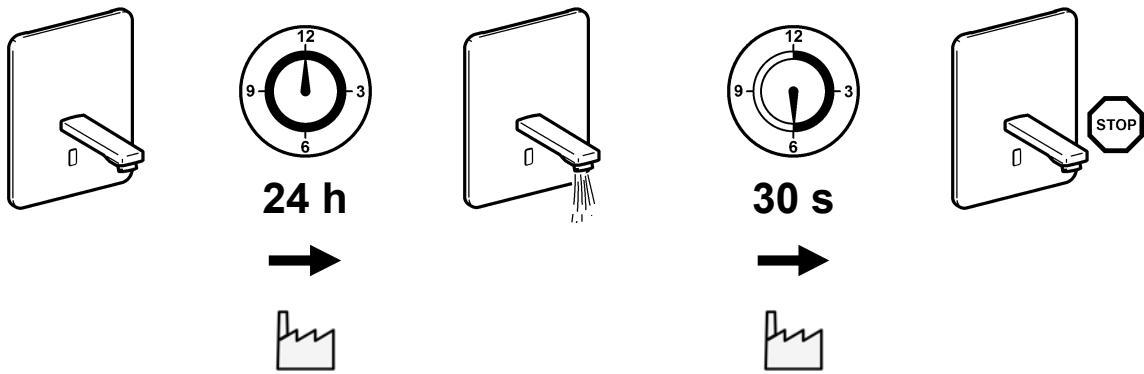

B

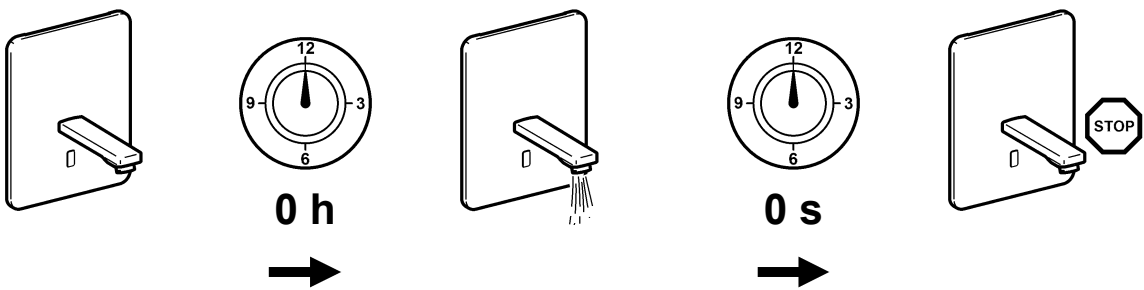

5

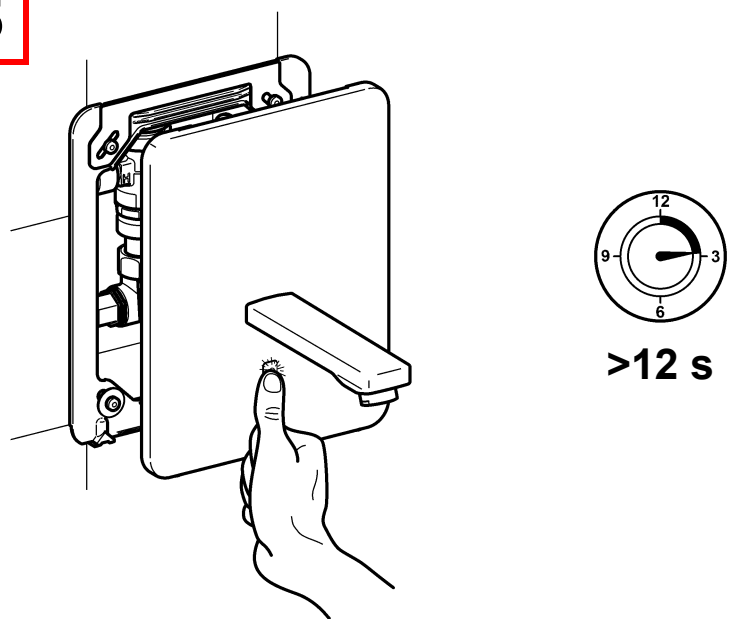

6

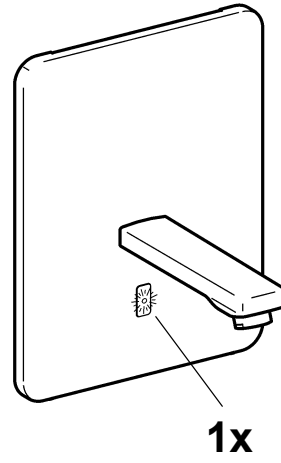
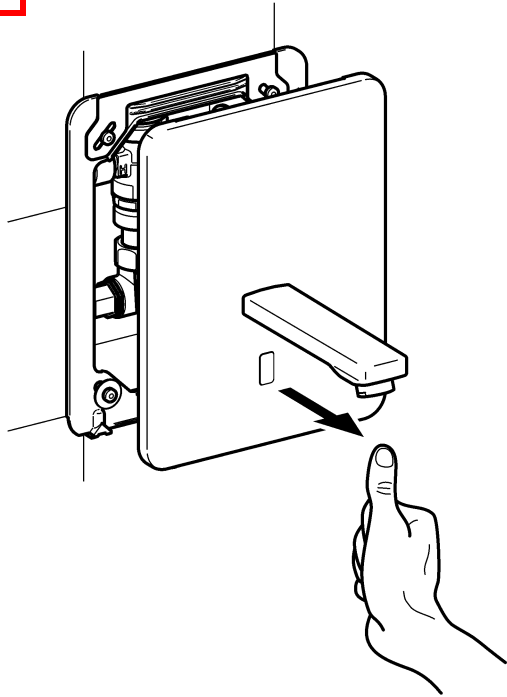

7

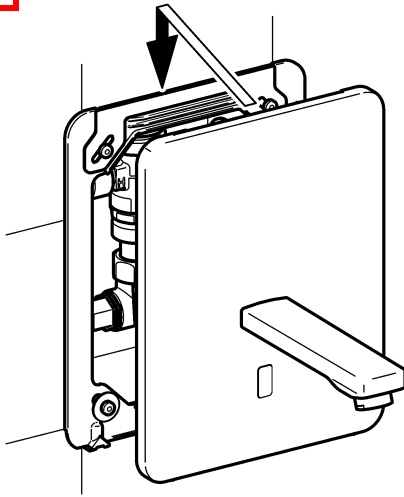

8

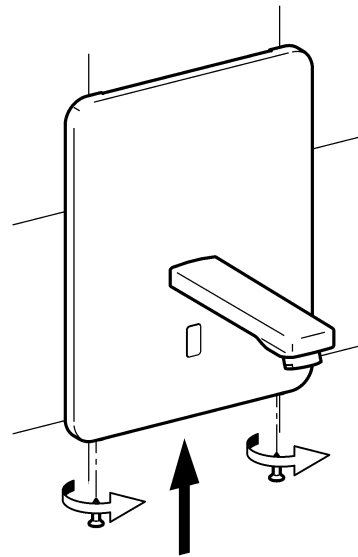

4. Armatur ausschalten

EN Switch off the valve

NL Armatuur uitschakelen

CS Vypnout armaturu

FR Désactiver la robinetterie de

PL Wyłączenie baterii

FI Hanan kytkeminen pois päältä

ES Desconectar la grifería

SV Avstängning av armatur

RU Выключение смесителя

IT Disattivazione della rubinetteria

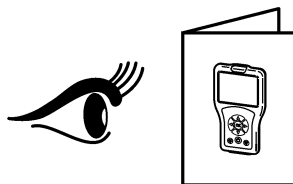
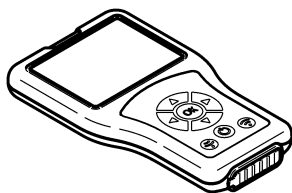

5. Dauerlauf starten

EN Start continual flow

NL Continue stroming starten

CS Spustit trvalý provoz

FR Démarrer la marche continue

PL Uruchomić stały wypływ wody

FI Tuotantokäytön aloittaminen

ES Iniciar el enjuague continuo

SV Starta kontinuerlig drift

RU запустить ресурс

IT Avviare l'erogazione continua

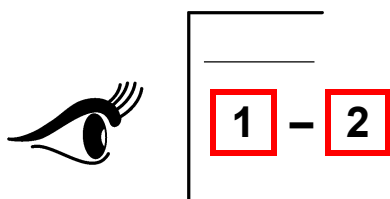
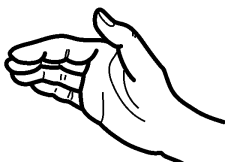

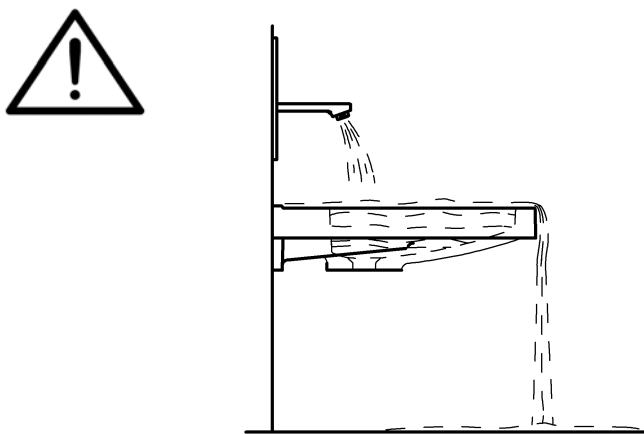
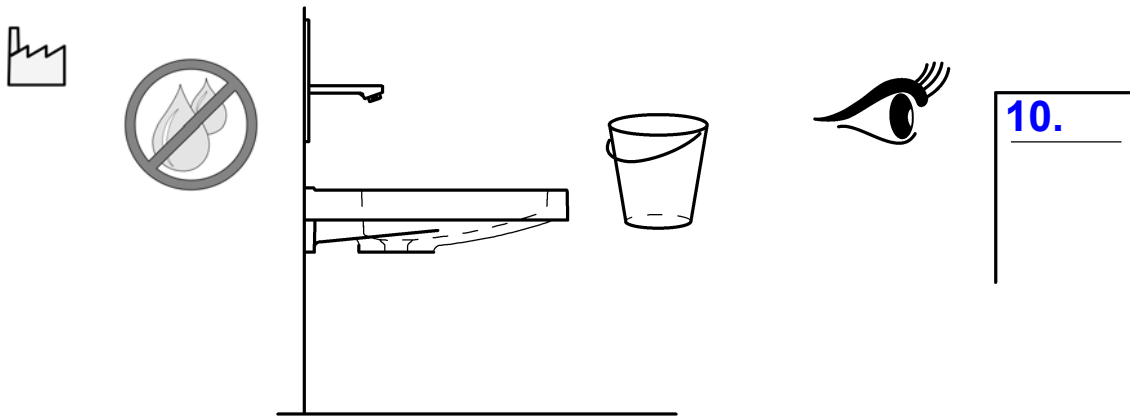

1

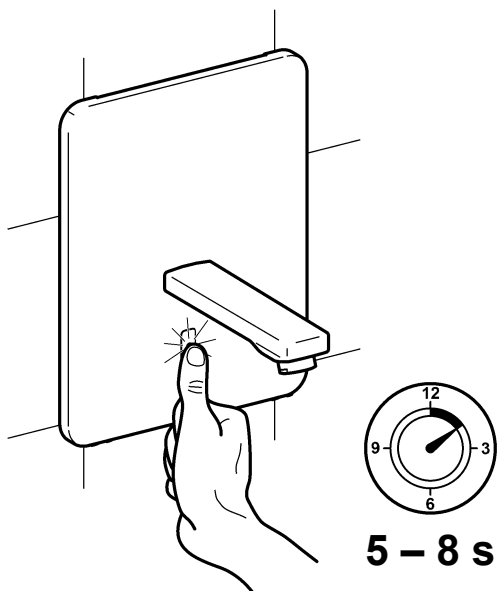

2

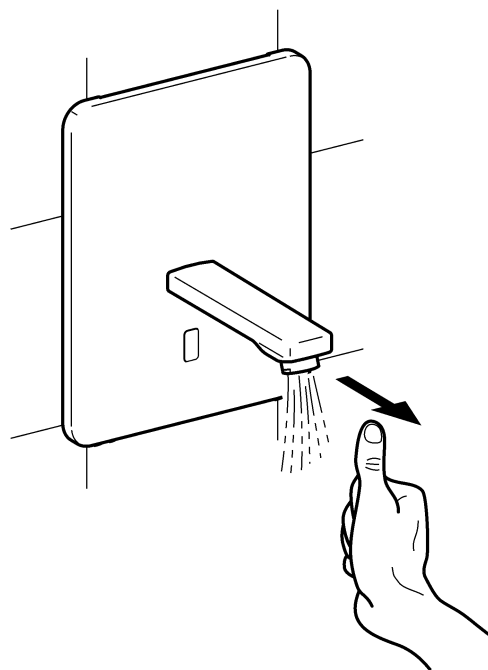

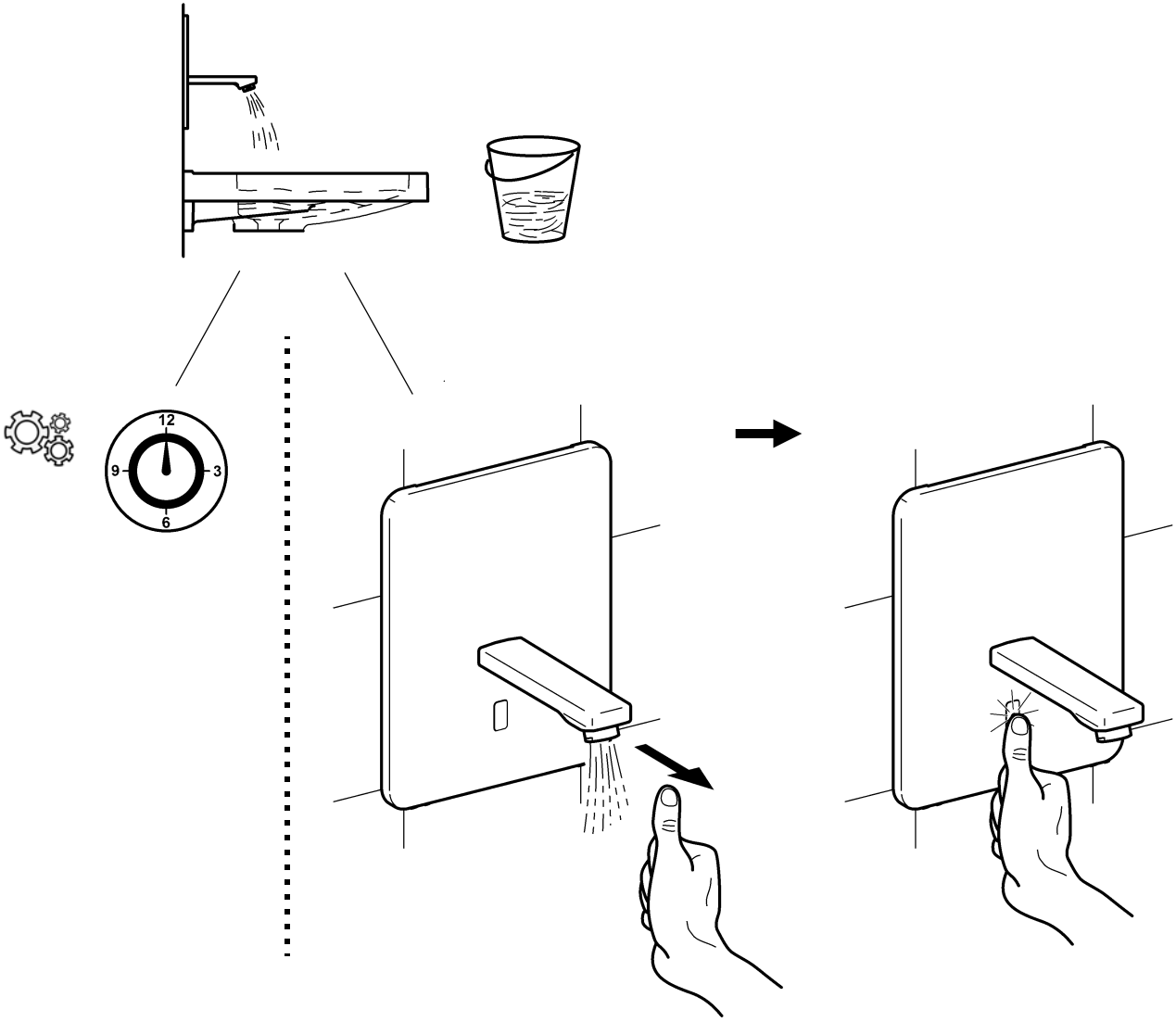

6. Reinigungsabschaltung einschalten

EN Switch on cleaning switch-off	NL Inschakelen van de reiniging shutdown	CS Vypínač pro čištění
FR Activer l'arrêt de nettoyage	PL Włączanie wyłączenia na czas czyszczenia	FI Aktivoida pesuseisokkien
ES Activar el apagado de limpieza	SV Aktivera rengörings avstängning	RU активировать чистка завершение работы
IT Attivare dello spegnimento per pulizia		

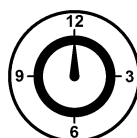
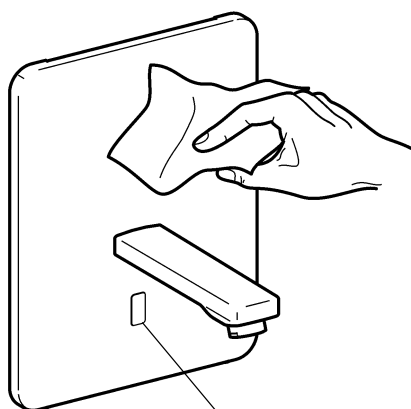
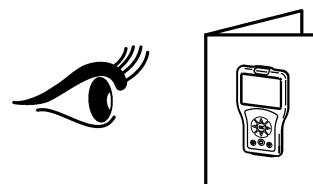
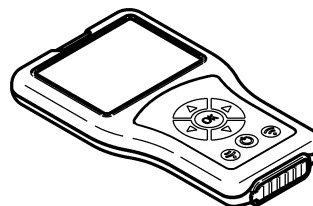
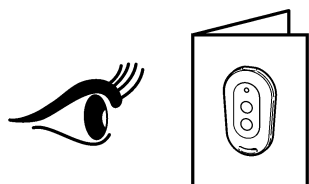

1 min

☀ 10s ☀ 10s ☀ ...

7. Erkennungs-Rückmeldung einschalten

EN Switch on detection feedback	NL Detectie-feedback inschakelen	CS Zapnutí identifikačního zpětného hlášení
FR Activation de la réponse d'identification	PL Włączyć komunikat zwrotny rozpoznania	FI Kytke tunnistuksen palaute päälle
ES Activar la confirmación de detección	SV Slå på respons vid detektering	RU Включить подтверждение идентификации
IT Attivare feedback rilevamento		

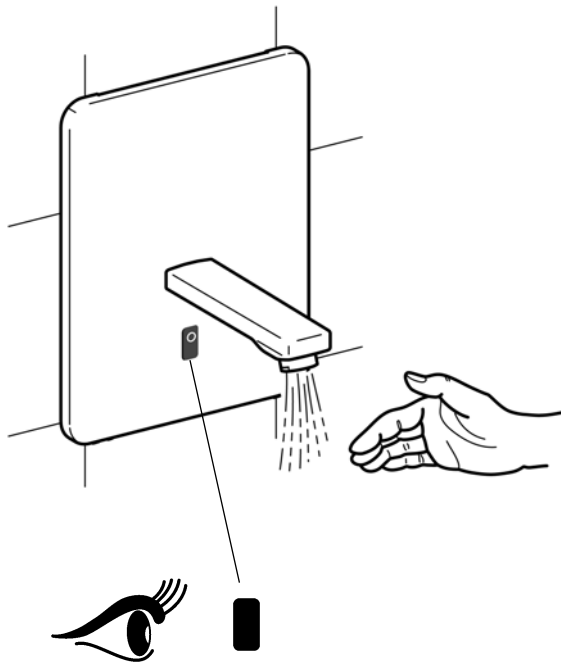
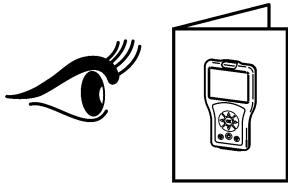
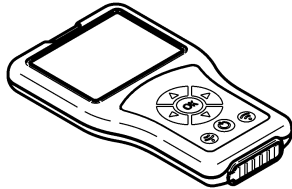

8. Reichweite einstellen

EN Adjusting the range

FR Réglage de la portée

ES Ajuste del alcance

IT Impostazione della portata

NL Actieradius instellen

PL Ustawienie zasięgu

SV Ställa in räckvidden

CS Nastavení dosahu

FI Tunnistusetäisyyden säätäminen

RU Настройка дальности действия

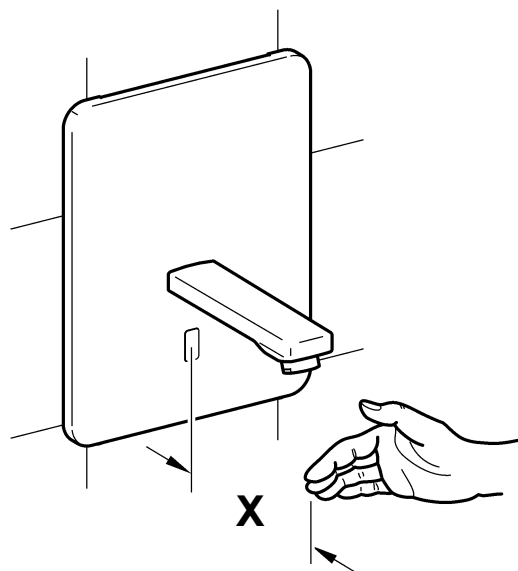

	X
F3ET1010	45% (~125)
F3ET1011	65% (~185)
F3ET1012	80% (~250)

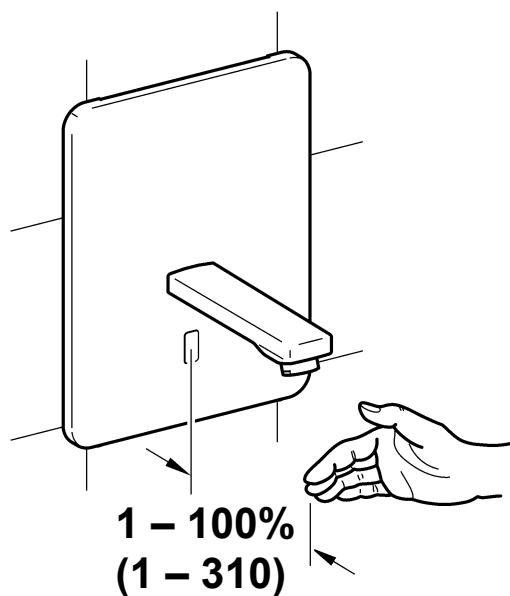
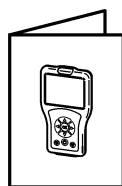
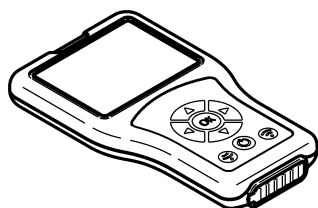

9. Hygienespülung einstellen

EN Setting the hygiene flush	NL Instellen van de hygiënespoeling	CS Nastavení hygienického proplachování
FR Réglage de la rinçage d'hygiène	PL Ustawianie spłukiwania higienicznego	FI Hygieniahuuhtelun säätäminen
ES Ajuste del higiene enjuague	SV Ställa in hygienspolning	RU установив гигиена смыва
IT Impostare lo igiene risciacquo		

EN

- ▶ C: Interval adjustable in h
- ▶ D: Flow duration adjustable in s

DE

- ▶ C: Intervall einstellbar in h
- ▶ D: Fließzeit einstellbar in s

FR

- ▶ C: intervalle réglable en h
- ▶ D: durée d'écoulement réglable en s

ES

- ▶ C: Intervalo ajustable en horas
- ▶ D: Tiempo de flujo activable en seg

IT

- ▶ C: intervallo impostabile in h
- ▶ D: durata di flusso impostabile in s

NL

- ▶ C: Interval instelbaar in u
- ▶ D: Stromingstijd instelbaar in s

PL

- ▶ C: odstęp czasu regulowany w godzinach
- ▶ D: czas przepływu regulowany w sekundach

SV

- ▶ C: Intervall kan ställas in i timmar
- ▶ D: Flödestid kan ställas in i sekunder

CS

- ▶ C: Interval s nastavením v h
- ▶ D: Doba průtoku s nastavením v s

FI

- ▶ C: Aikaväli, asetettavissa h
- ▶ D: Virtausaika, asetettavissa s

RU

- ▶ C: интервал задается в ч
- ▶ D: время течения задается в сек.

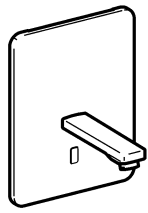

C

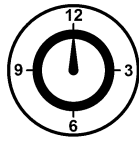

24 h

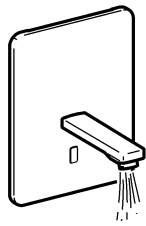

D

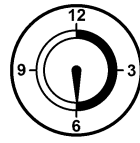

30 s

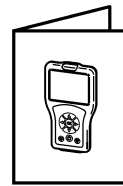
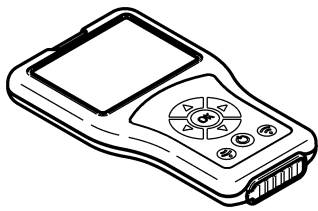
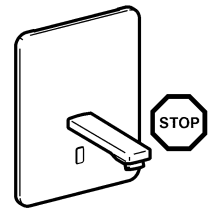

C

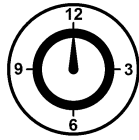

1 - 255 h

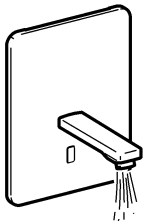

D

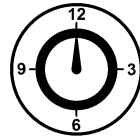

1 - 255 s

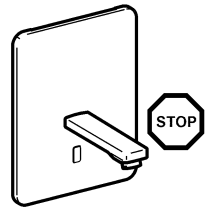

10. Dauerlauf einstellen

EN Setting continuous operating mode	NL Continue stroming instellen	CS Nastavení pomalejšího toku
FR Réglage du fonctionnement en continu	PL Ustawienie ciągłego wypływu	FI Tuotantokäytön säätäminen
ES Ajuste del funcionamiento ininterrumpido	SV Ställa in permanent flöde	RU Настройка непрерывного режима
IT Impostazione del flusso continuo		

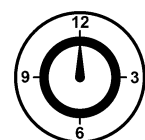
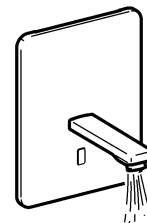
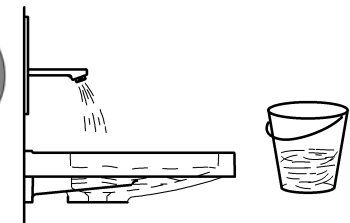
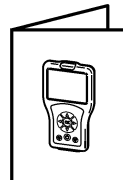
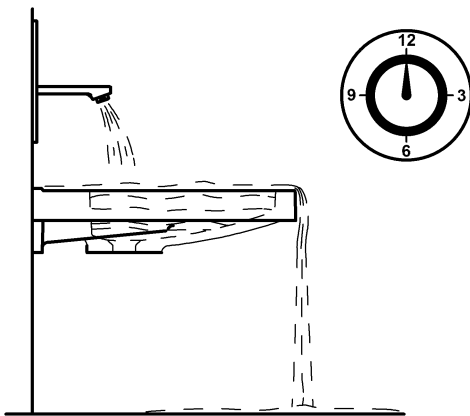
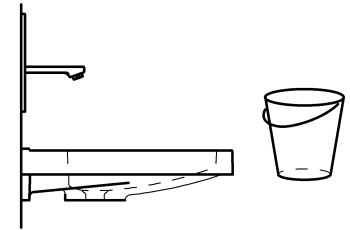

60 s

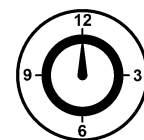
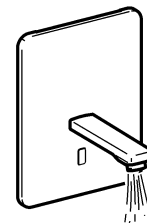
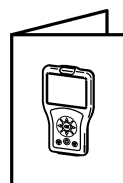
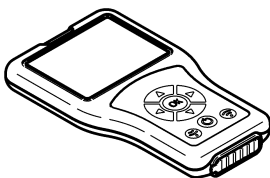

1 – 255 s

11. Reinigungsabschaltung einstellen

EN Set the range
FR Régler le rayon d'action
ES Regular el alcance
IT Impostare la portata

NL Actieradius instellen
PL Ustawienie zasięgu
SV Ställa in räckvidden

CS Nastavení dosahu
FI Aseta ulottuma
RU установить диапазон значений

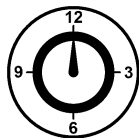
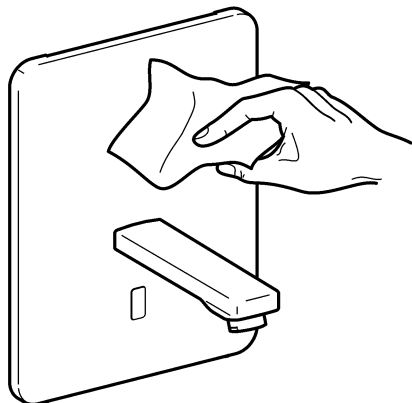

1 min

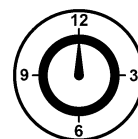
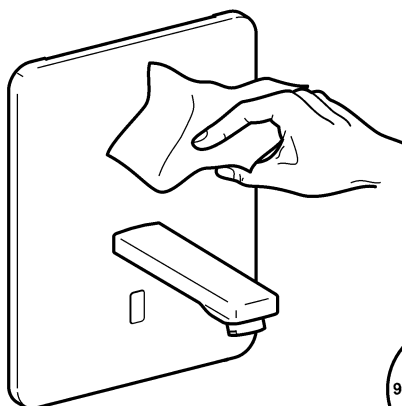
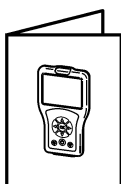
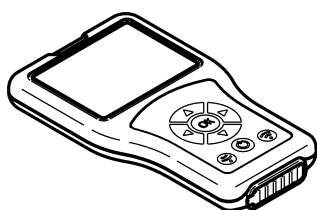

1 – 255 min

12. Wartung

EN Maintenance
FR Maintenance
ES Mantenimiento
IT Manutenzione

NL Onderhoud
PL Konserwacja
SV Underhåll

CS Varování
FI Huolto
RU Техническое обслуживание



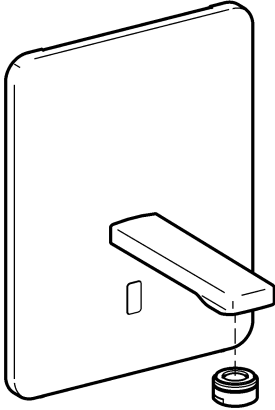

22 mm

1

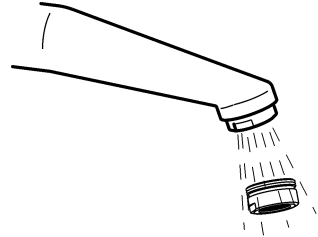

2



15.



16.

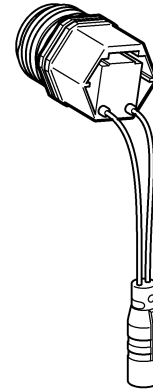

17.

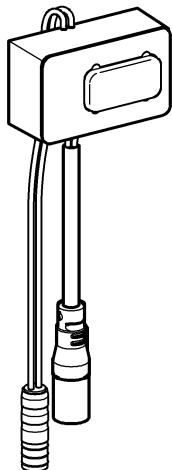

13. Abdeckplatte abnehmen

EN Remove the cover plate

NL Afdekplaat weghalen

CS Sejmutí krycí desky

FR Retrait de la plaque de protection

PL Zdejmowanie płytki maskującej

FI Peitelevyn irrottaminen

ES Retirar la placa cobertora

SV Avlägsna täckplattan

RU Демонтаж крышки

IT Rimozione della piastrina di copertura

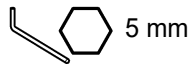
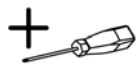

1

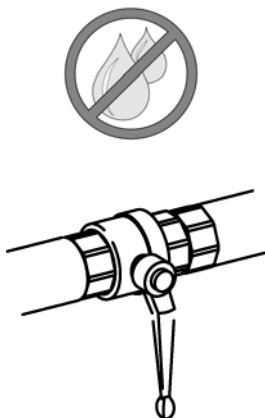

2

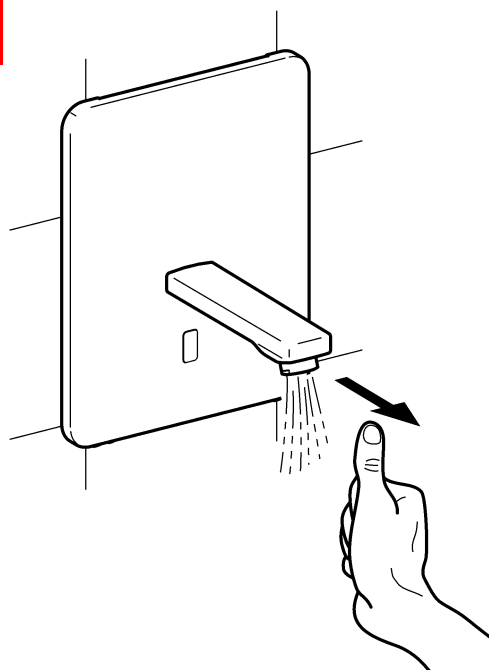

3

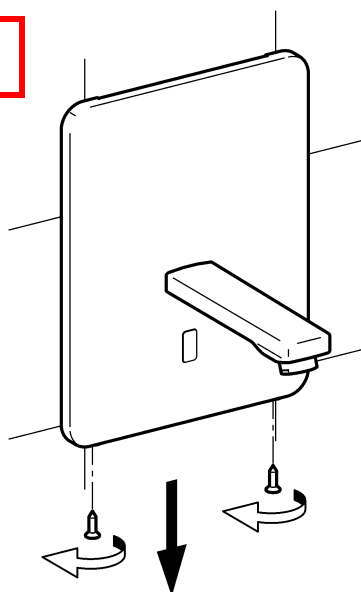

4

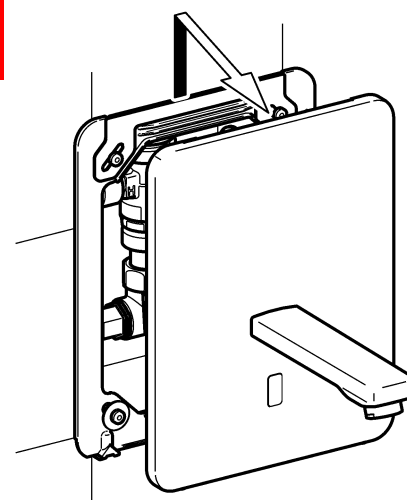

5

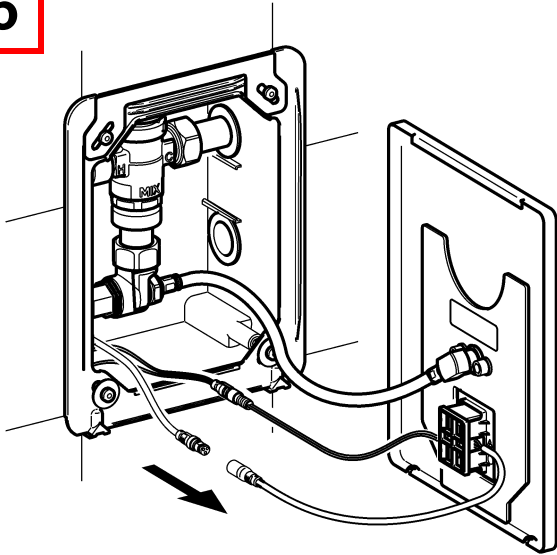

6

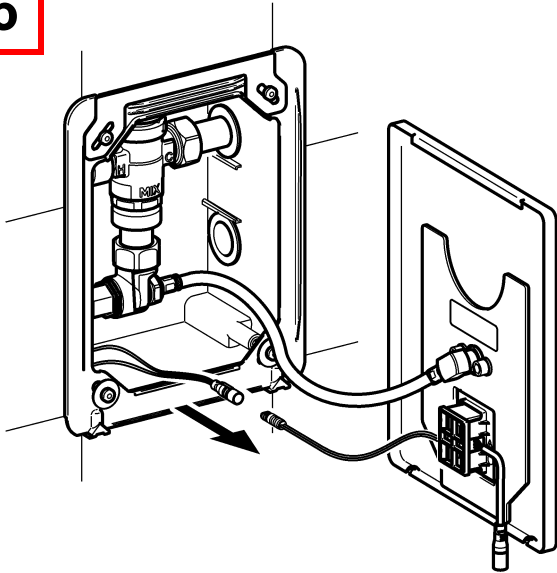

7

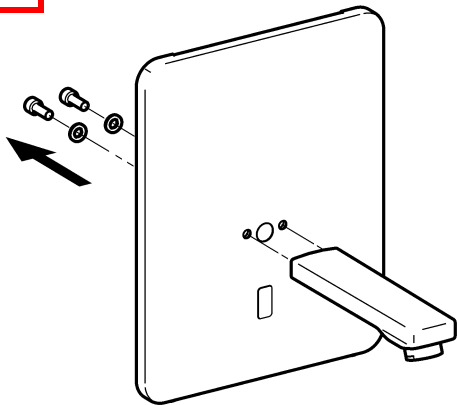

8

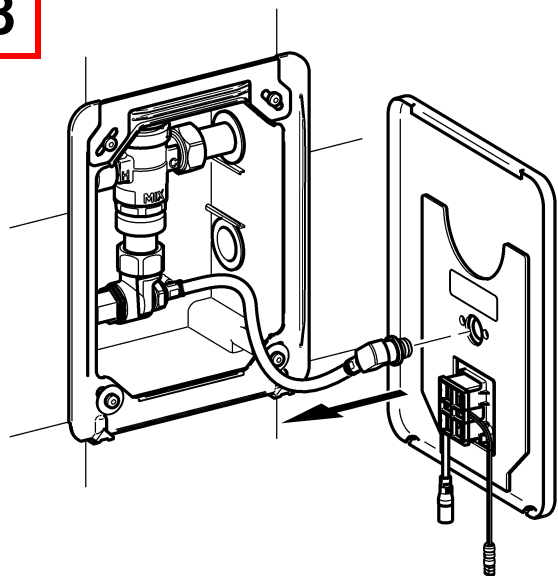

14. Abdeckplatte montieren

EN Install the cover plate

NL Afdekplaat monteren

CS Montáž krycí desky

FR Montage de la plaque de protection

PL Montaż płytki maskującej

FI Peitelevyn asennus

SV Montera täckplattan

RU Установка крышки

ES Montar la placa cobertora

IT Montaggio della piastrina di copertura

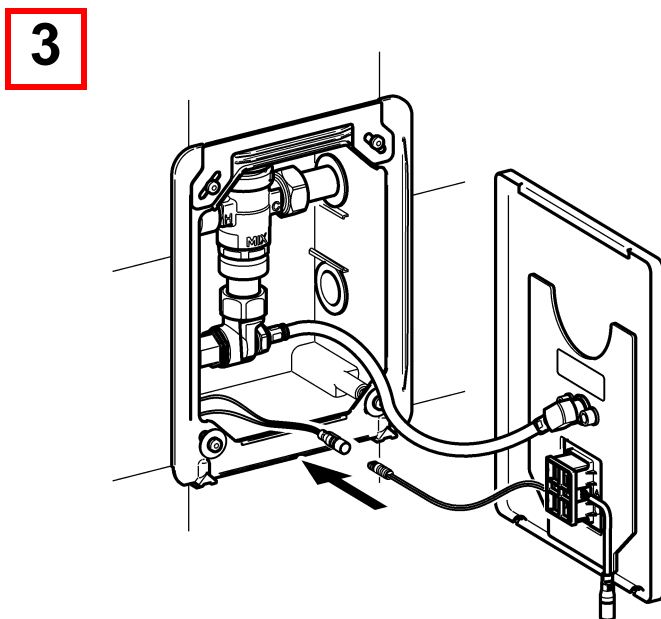
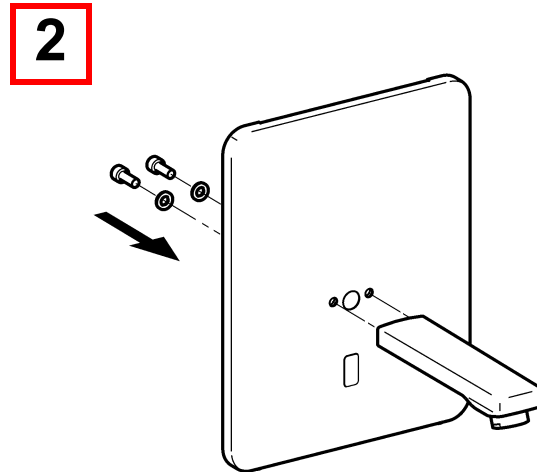
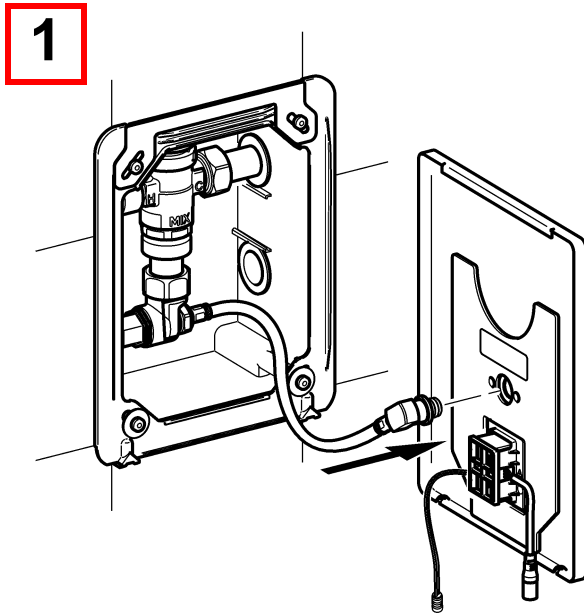
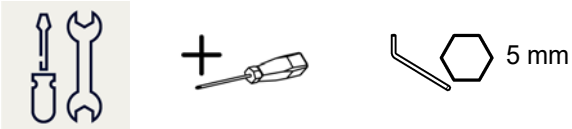

4

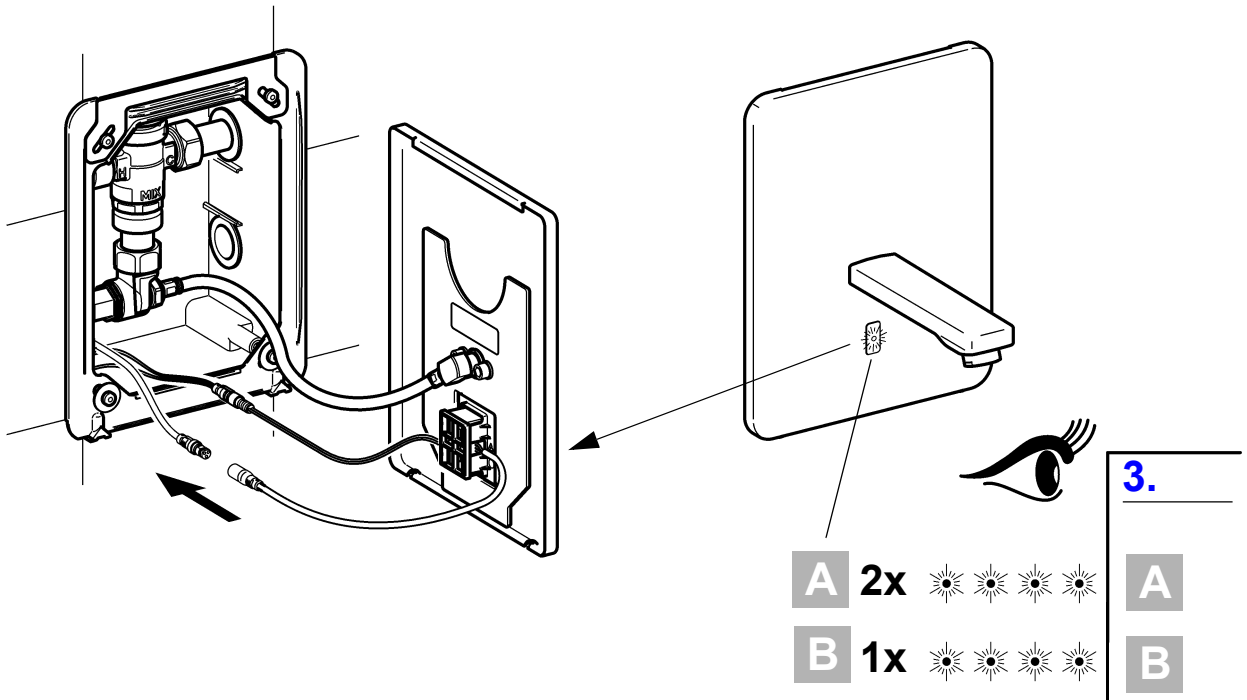

5

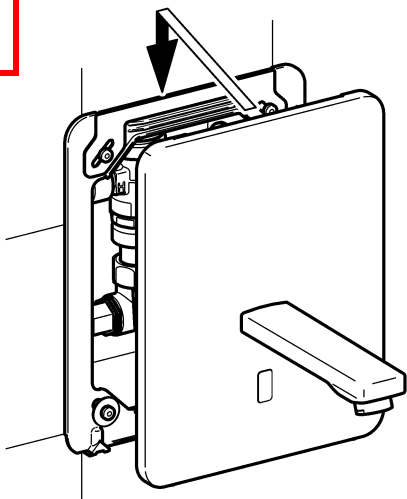

6

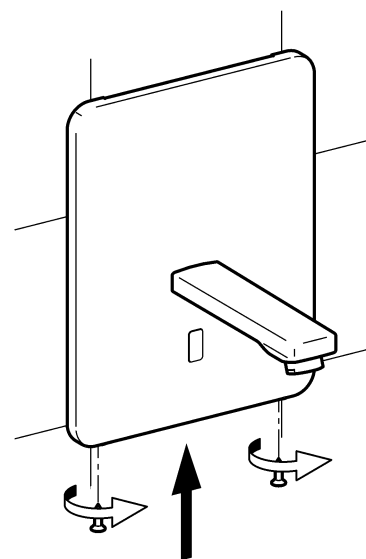

7

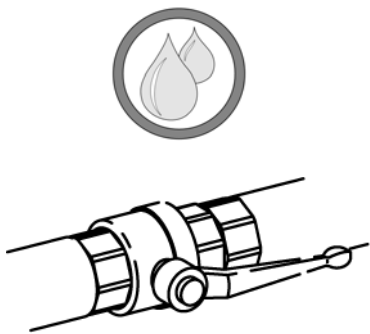

15. Siebe wechseln

EN Replace the filters
 FR Remplacement les filtres
 ES Cambiar los tamices
 IT Sostituire i filtri

NL Zeven vervangen
 PL Wymiana sit
 SV Byt filter

CS Vyměňte síto
 FI Siivilän vaihto
 RU Сменить сеточки

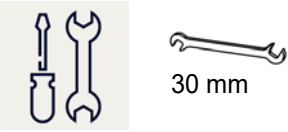

1



13.

2

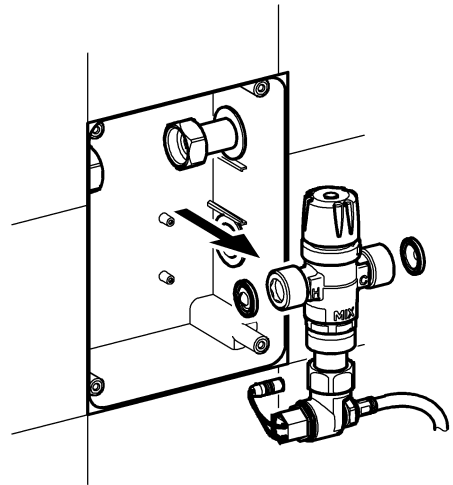

3

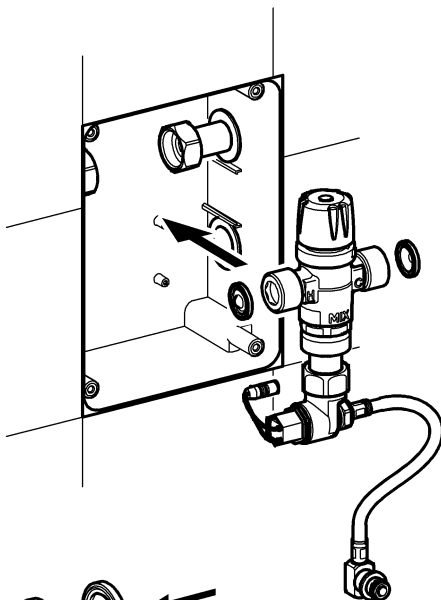

4



14.

16. Magnetventilkartusche wechseln

EN Replacing the solenoid valve cartridge	NL Magneetventielpatroon verandering	CS Výměna kartuše s magnetickým ventilem
FR Remplacement de la cartouche d'électrovanne	PL Wymiana wkładu zaworu elektromagnetycznego	FI Magneettiventtiilipanoksen vaihtaminen
ES Cambiar cartucho de la válvula electromagnética	SV Byta magnetventilpatron	RU Замена картриджа электромагнитного клапана
IT Sostituzione della cartuccia della valvola elettromagnetica		



1



13.

2

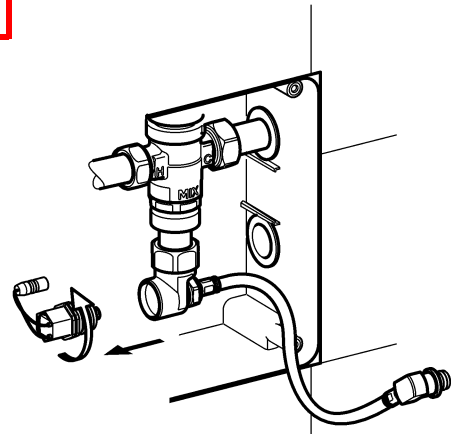

3

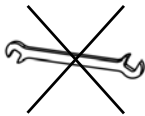

4



14.

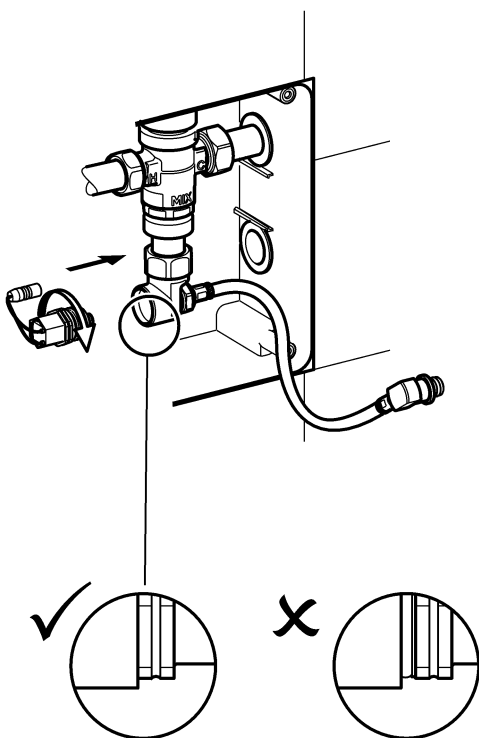

17. Sensor wechseln

EN Replace sensor
FR Changer le capteur
ES Cambiar el sensor
IT Cambiare il sensore

NL Sensor vervangen
PL Wymienić czujnik
SV Byt sensor

CS Vyměňte snímač
FI Anturi vaihto
RU Замена Датчик

1

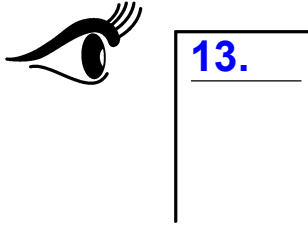

2

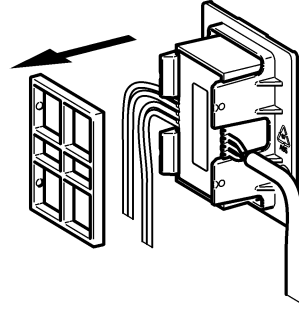

3

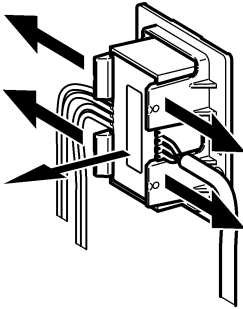

4

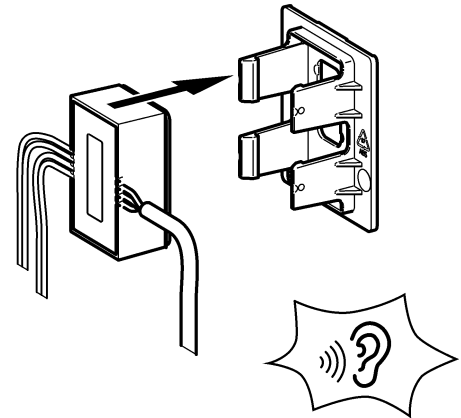

5

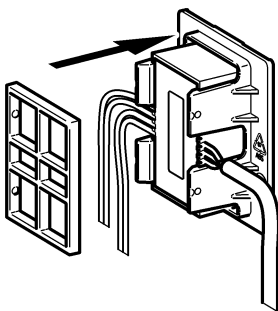

6

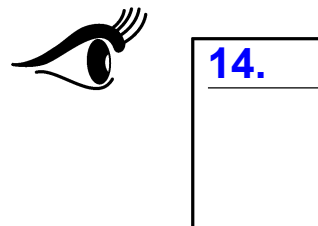

18. Ersatzteile

EN Replacement parts
FR Pièces de rechange
ES Piezas de recambio
IT Pezzi di ricambio

NL Reserveonderdelen
PL Części zamienne
SV Reservdelar

CS Náhradní díly
FI Varaosat
RU Запчасти

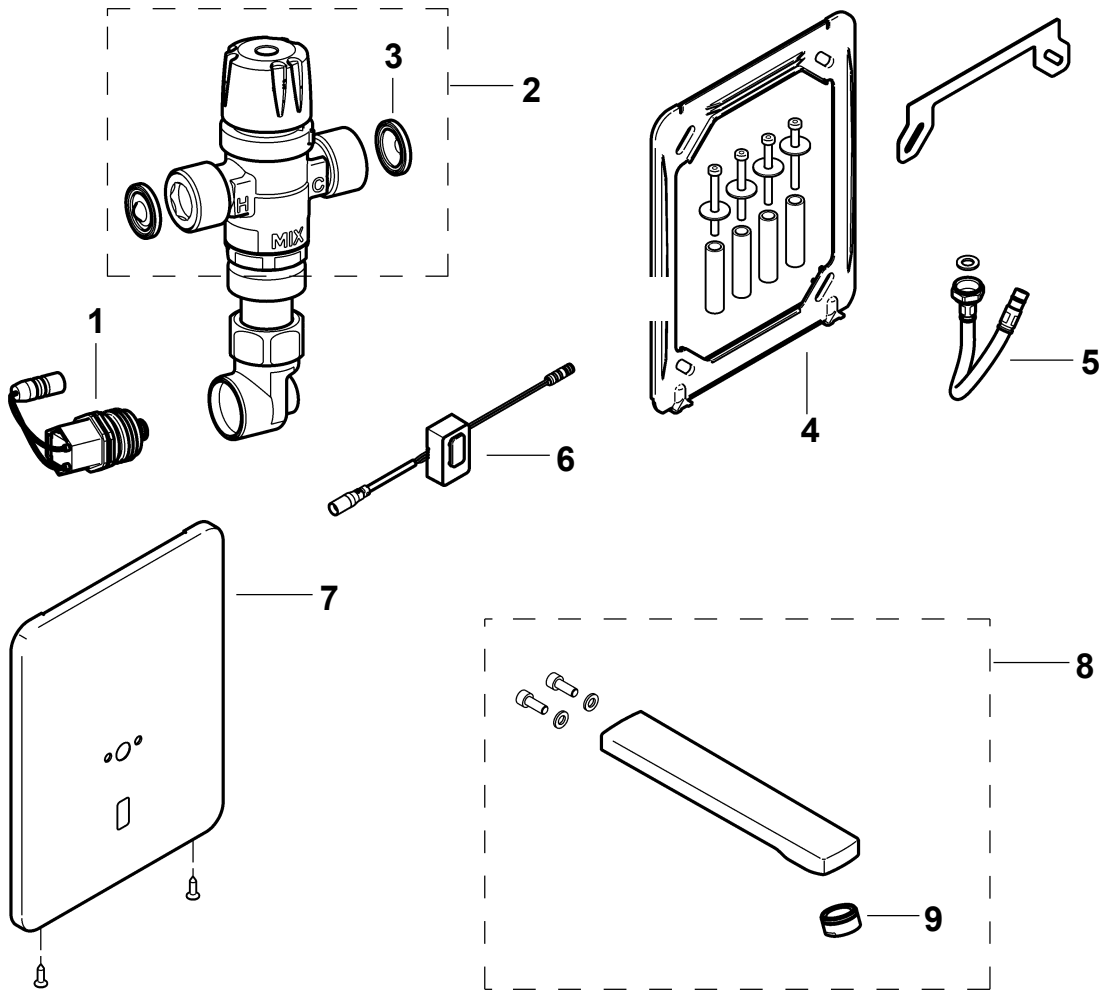

1 2030045522
ACXX9002

2 2030049064
ASET1005

3 2000104706 a)
ASXX9011

4 2030045472
ASXX9001

5 2030048523
ASET1003

6 **F3ET1010:**
2030041452

ASEX1002

F3ET1011:

2030041454

ASEX1003

F3ET1012:

2030041455

ASEX1004

7 2030049060

ASEX1017

8 **130 mm:**

2030048530

ASEX1014

190 mm:

2030048532

ASEX1015

250 mm:

2030048536

ASEX1016

9 2030012352 a)

ETAPS0037

EN a) 10 pieces

ES a) 10 piezas

PL a) 10 sztuk

FI a) 10 kappaletta

DE a) 10 Stück

IT a) 10 pezzi

SV a) 10 styck

RU a) 10 штук

FR a) 10 pièces

NL a) 10 stuk

CS a) 10 kusů

19. Zubehör

EN Accessories
FR Accessoire
ES Accesorios
IT Accessori

NL Toebehoren
PL Akcesoria
SV Tillbehör

CS Příslušenství
FI Lisävarusteet
RU принадлежности

1

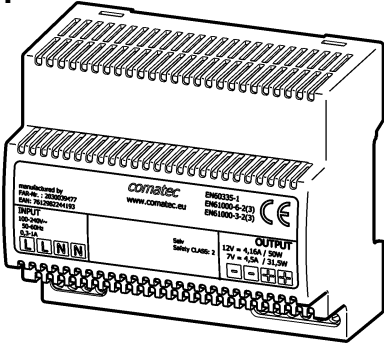

2

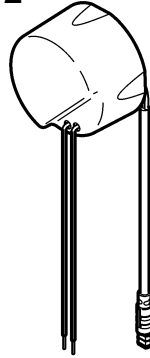

1 2030039477
ACEX9001

2 2030039825
ACEX9003

3 **5m:**
2030043814
ACEX9010

4 2030036654
ACEX9005

5 2030036849
ACEX9004

6 2000104778
ZTAPS0005

7 2000109019
ZWSP0024

8 **0,5 l:**
2000105091
ZWSP0023

3

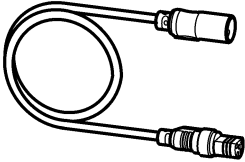

4

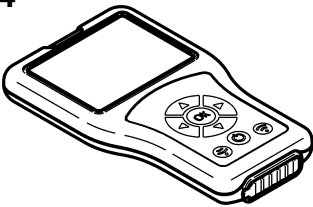

5



6

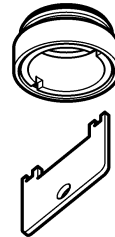

7



Australia

PR Kitchen and
Water Systems Pty Ltd
Dandenong South VIC 3175
Phone +61 3 9700 9100

Austria

KWC Austria GmbH
6971 Hard, Austria
Phone +43 5574 6735 0

**Belgium, Netherlands &
Luxembourg**

KWC Aquarotter GmbH
9320 Aalst; Belgium
Phone +31 (0) 492 728 224

Czech Republic

KWC Aquarotter GmbH
14974 Ludwigsfelde, Germany
Phone +49 3378 818 309

France

KWC Austria GmbH
6971 Hard, Austria
Phone +33 800 909 216

Germany

KWC Aquarotter GmbH
14974 Ludwigsfelde
Phone +49 3378 818 0

Italy

KWC Austria GmbH
6971 Hard, Austria
Numero Verde +39 800 789 233

Middle East

KWC ME LLC Ras Al Khaimah,
United Arab Emirates
Phone +971 7 2034 700

Poland

KWC Aquarotter GmbH
14974 Ludwigsfelde, Germany
Phone +48 58 35 19 700

Spain

KWC Austria GmbH
6971 Hard, Austria
Phone +43 5574 6735 211

Switzerland & Liechtenstein

KWC Group AG
5726 Unterkulm, Switzerland
Phone +41 62 768 69 00

Turkey

KWC ME LLC Ras Al Khaimah,
United Arab Emirates
Phone +971 7 2034 700

United Kingdom

KWC DVS Ltd - Northern Office
Barlborough S43 4PZ
Phone +44 1246 450 255

KWC DVS Ltd - Southern Office
Paignton TQ4 7TW
Phone +44 1803 529 021

EAST EUROPE

Bosnia Herzegovina
Bulgaria | Croatia
Hungary | Latvia
Lithuania | Romania
Russia | Serbia | Slovakia
Slovenia | Ukraine

KWC Aquarotter GmbH
14974 Ludwigsfelde, Germany
Phone +49 3378 818 261

SCANDINAVIA & ESTONIA

Finland | Sweden | Norway
Denmark | Estonia

KWC Nordics Oy
76850 Naarajärvi, Finland
Phone +358 15 34 111

OTHER COUNTRIES

KWC Austria GmbH
6971 Hard, Austria
Phone +43 5574 6735 0

