

SIRIUS

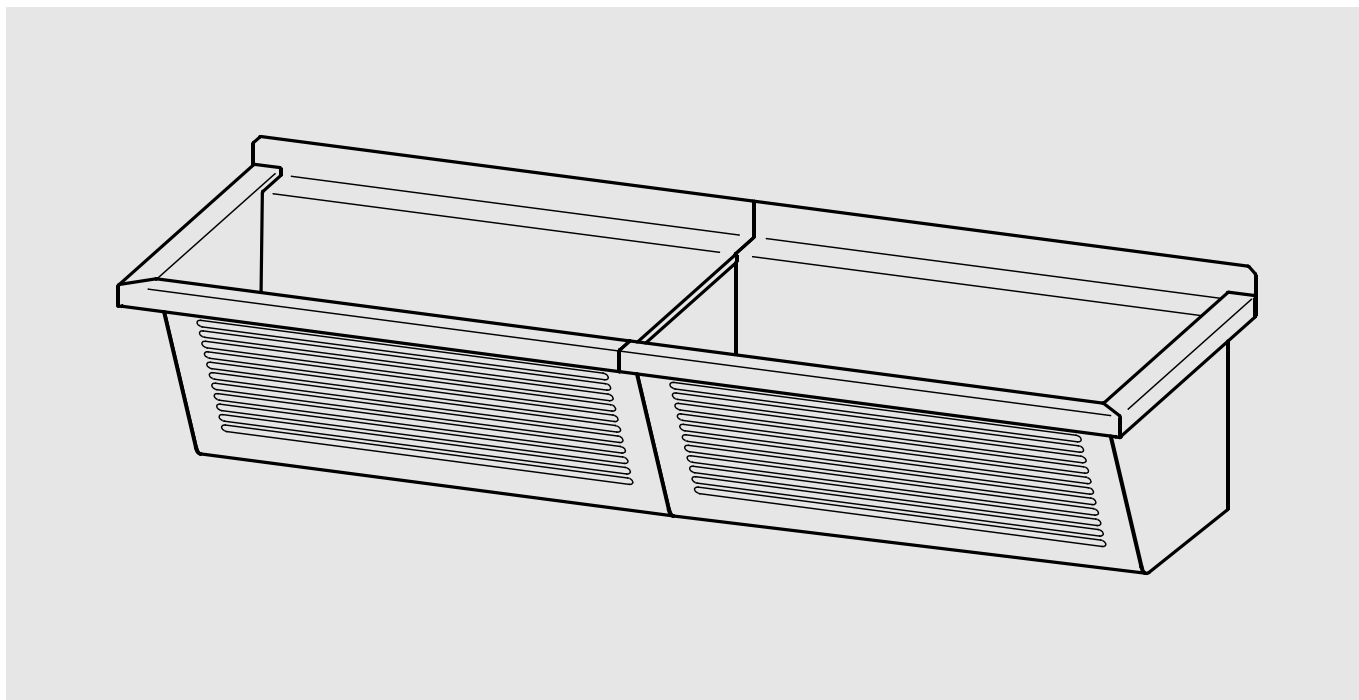

BS315N

2030045755

1420×346×500 mm

DE	Montage- und Betriebsanleitung	Waschtrog
EN	Installation and operating instructions	Washtrough
FR	Notice de montage et de mise en service	Bac de lavage
ES	Instrucciones de montaje y servicio	Fregadero
IT	Istruzioni per il montaggio e l'uso	Lavatoio
NL	Montage- en bedrijfsinstructies	Wastrog
PL	Instrukcja montażu i obsługi	Komora gospodarcza
SV	Monterings- och driftinstruktion	Tvättlåda
CS	Návod pro montáž a provoz	Prací koryto
FI	Asennus- ja käyttöohje	Kodinhoitoallas
RU	Инструкция по монтажу и вводу в эксплуатацию	

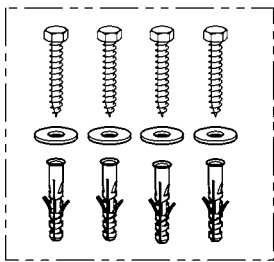
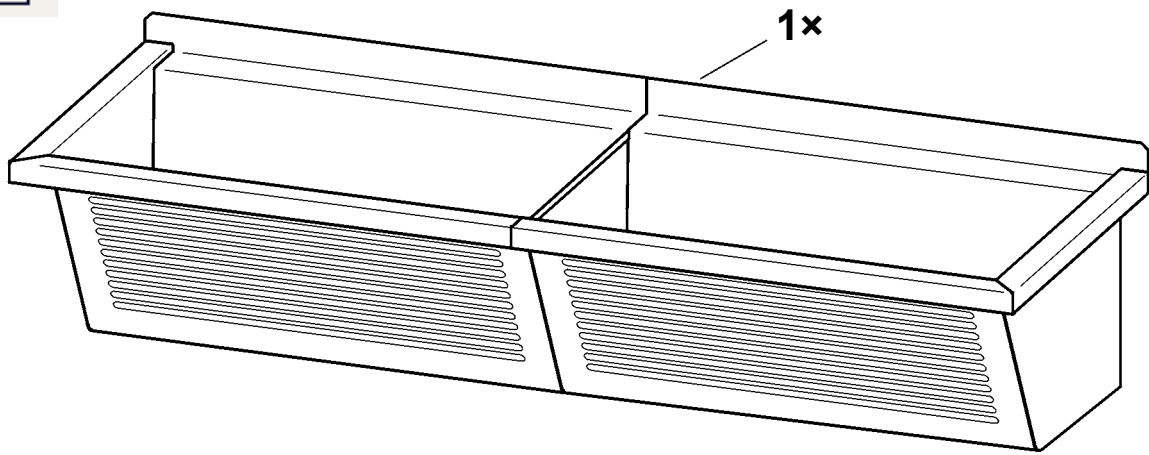

1x

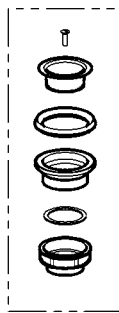

2x



2x

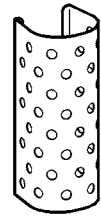

2x

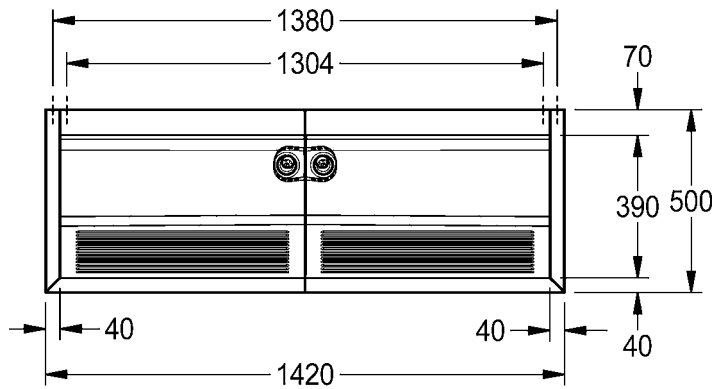
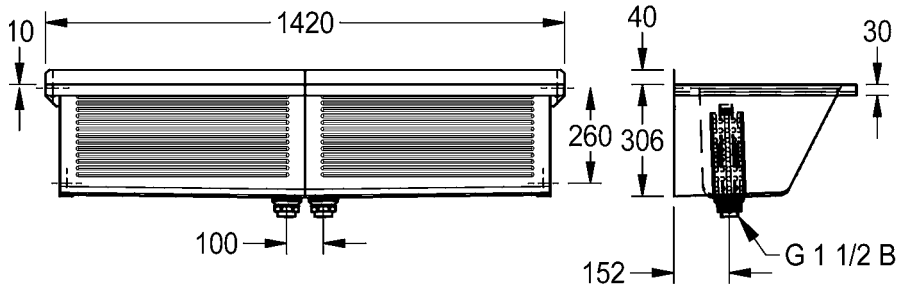
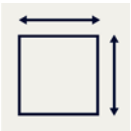

EN Installation and operating instructions

Important notes

- ▶ Screws delivered with the product are adequate for concrete walls. For other kind of walls, please chose the adequate fixing material.

PL Instrukcja montażu i obsługi

Ważne wskazówki

- ▶ śruby dostarczone z produktem są przeznaczone do ścian betonowych. W przypadku mocowania w innych ścianach należy dobrać odpowiednie do nich materiały mocujące.

FR Notice de montage et de mise en service

Remarques importantes

- ▶ Les vis fournies avec le produit sont prévues pour des murs en béton. Pour les autres types de murs, veuillez choisir le matériel de fixation adapté.

ES Instrucciones de montaje y servicio

Indicaciones importantes

- ▶ Tenga en cuenta que los tornillos suministrados con el producto son adecuados para paredes de hormigón. Para otro tipo de paredes, elija el material de fijación idóneo.

IT Istruzioni per il montaggio e l'uso

Avvertenze importanti

- ▶ le viti fornite con il prodotto sono adatte per pareti in calcestruzzo. Per altri tipi di pareti, si prega di scegliere il materiale di fissaggio adeguato.

DE Montage- und Betriebsanleitung

Wichtige Hinweise

- ▶ Die mitgelieferten Schrauben sind für Betonwände geeignet. Für andere Materialien wählen Sie bitte das passende Befestigungsmaterial.

SV Monterings- och driftinstruktion

Viktiga informationer

- ▶ Observera att skruvarna som medföljer produkten är lämpliga för betongväggar. Välj lämpliga fästmaterial vid andra typer av väggar.

CS Návod pro montáž a provoz

Důležité pokyny

- ▶ Šroubky dodávané s výrobkem jsou vhodné pro betonové stěny. Pro jiné druhy stěn zvolte vhodný upevňovací materiál.

FI Asennus- ja käyttöohje

Tärkeitä ohjeita

- ▶ Tuotteen mukana toimitetut ruuvit on tarkoitettu betoniseiniin. Valitse muihin seiniin asianmukaiset kiinnikkeet.

RU Инструкция по монтажу и вводу в эксплуатацию

Важные указания

- ▶ Входящие в комплект поставки винты подходят для бетонных стен. Для других материалов выбирайте подходящий крепежный материал.

Belangrijke aanwijzingen

- ▶ De schroeven die met het product meegeleverd worden, zijn geschikt voor betonnen muren. Voor andere soorten muren, het geschikte bevestigingsmateriaal kiezen.



1. Montage

EN Installation
FR Montage
ES Montaje
IT Montaggio

NL Montage
PL Montaż
SV Montering

CS Montáž
FI Asennus
RU Монтаж

1

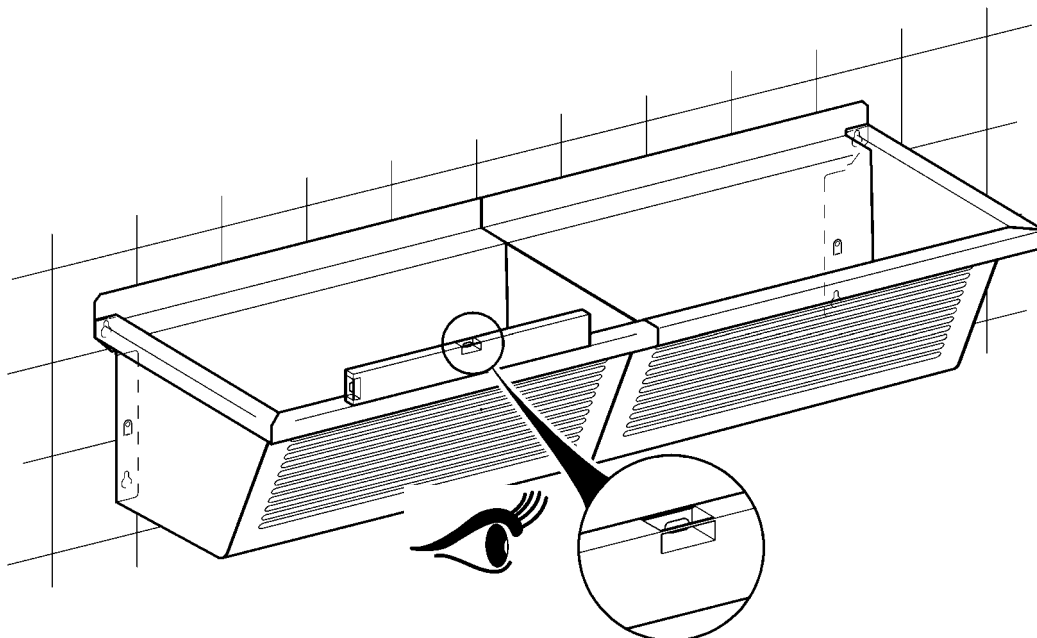

2

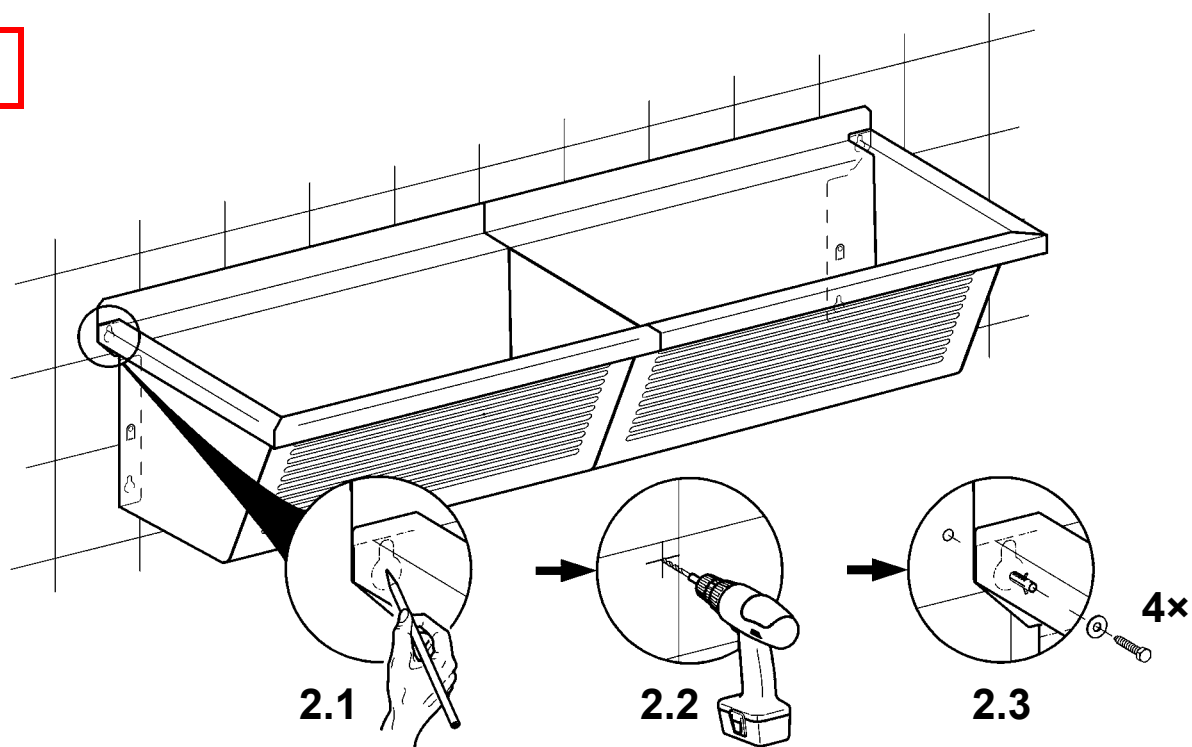

3

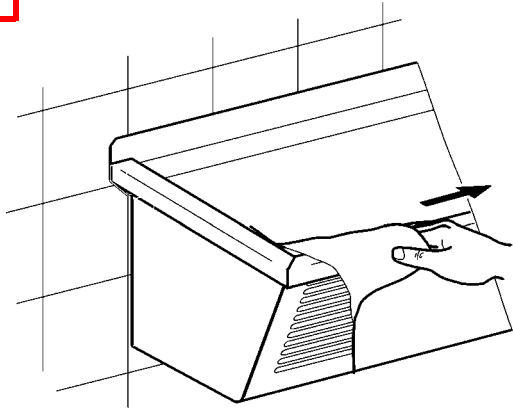

4

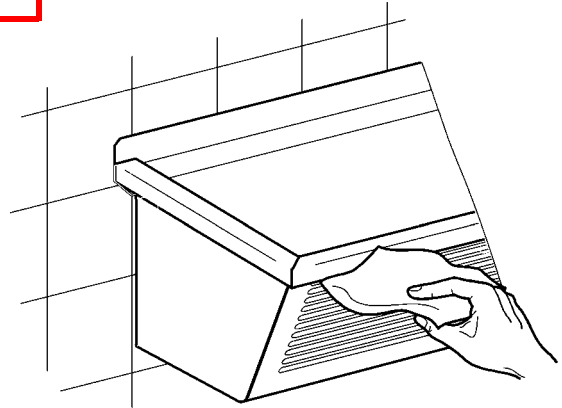

5

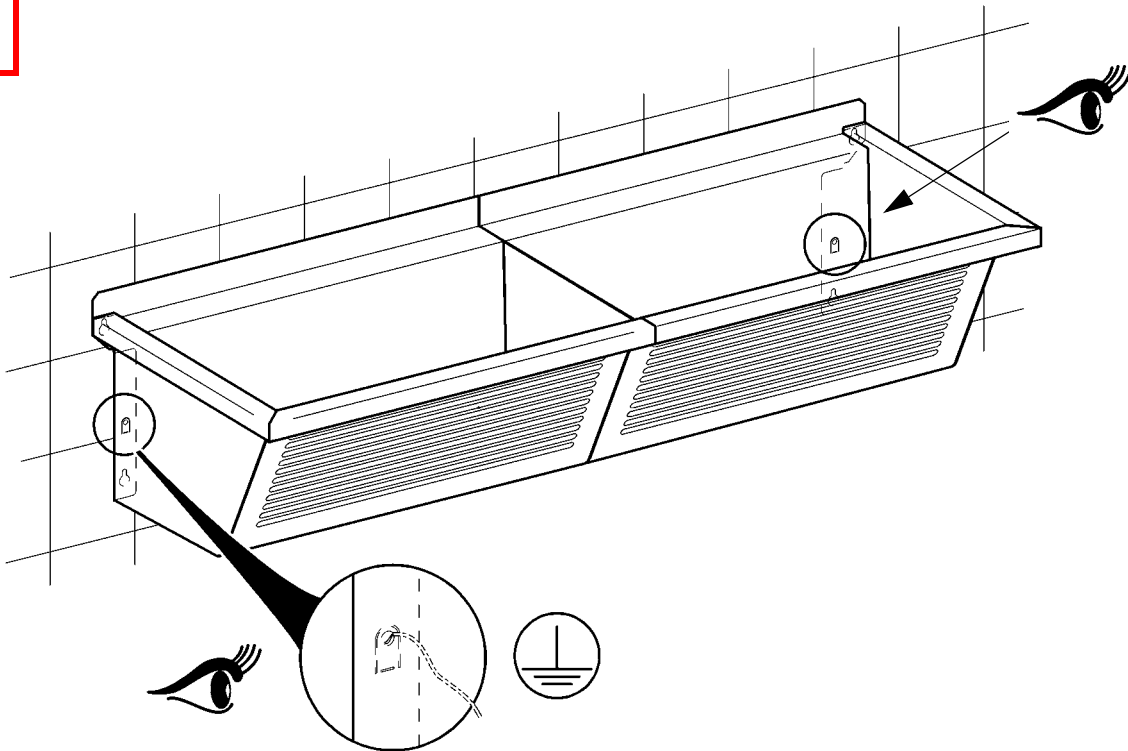

6

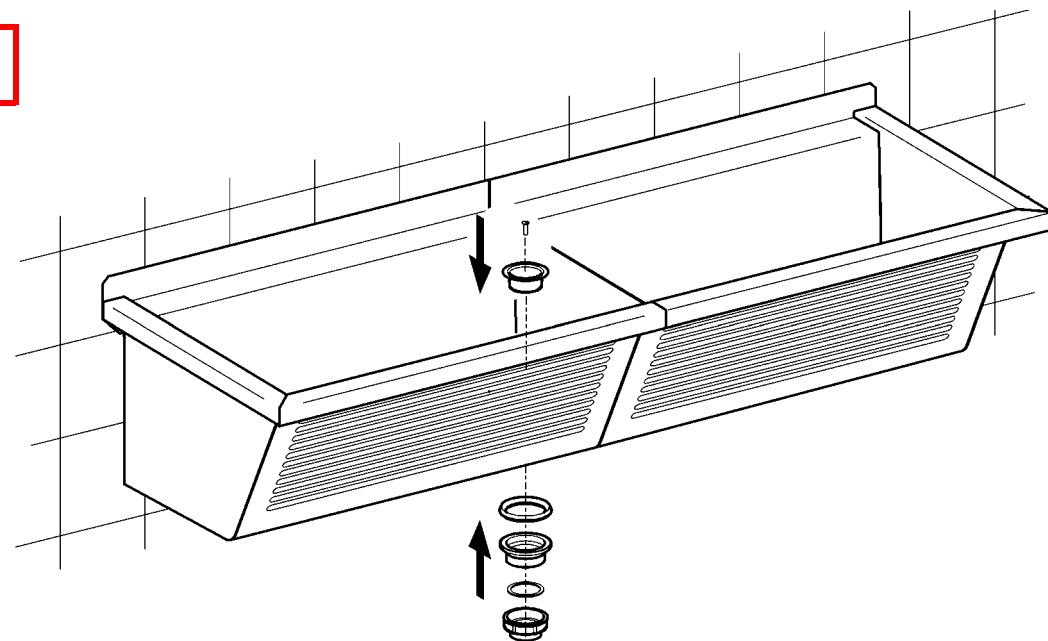

2. Ersatzteile

EN Replacement parts
FR Pièces de rechange
ES Piezas de recambio
IT Pezzi di ricambio

NL Reserveonderdelen
PL Części zamienne
SV Reservdelar

CS Náhradní díly
FI Varaosat
RU Запчасти

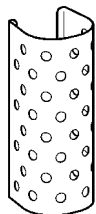

2000103421
ESIRX020



2000103408
ESIRX008

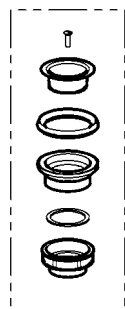

2000103426
EMAXI001

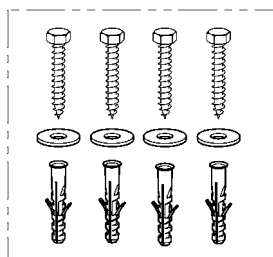

2030047178
EPL0001

3. Zubehör

EN Accessories
FR Accessoire
ES Accesorios
IT Accessori

NL Toebehoren
PL Akcesoria
SV Tillbehör

CS Příslušenství
FI Lisävarusteet
RU принадлежности

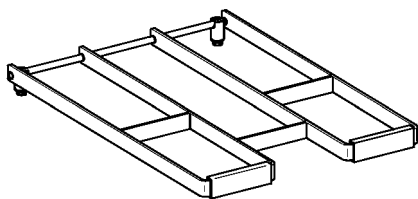

2000102678
ZSIRX001

Australia

PR Kitchen and
Water Systems Pty Ltd
Dandenong South VIC 3175
Phone +61 3 9700 9100

Austria

KWC Austria GmbH
6971 Hard, Austria
Phone +43 5574 6735 0

**Belgium, Netherlands &
Luxembourg**

KWC Aquarotter GmbH
9320 Aalst; Belgium
Phone +31 (0) 492 728 224

Czech Republic

KWC Aquarotter GmbH
14974 Ludwigsfelde, Germany
Phone +49 3378 818 309

France

KWC Austria GmbH
6971 Hard, Austria
Phone +33 800 909 216

Germany

KWC Aquarotter GmbH
14974 Ludwigsfelde
Phone +49 3378 818 0

Italy

KWC Austria GmbH
6971 Hard, Austria
Numero Verde +39 800 789 233

Middle East

KWC ME LLC Ras Al Khaimah,
United Arab Emirates
Phone +971 7 2034 700

Poland

KWC Aquarotter GmbH
14974 Ludwigsfelde, Germany
Phone +48 58 35 19 700

Spain

KWC Austria GmbH
6971 Hard, Austria
Phone +43 5574 6735 211

Switzerland & Liechtenstein

KWC Group AG
5726 Unterkulm, Switzerland
Phone +41 62 768 69 00

Turkey

KWC ME LLC Ras Al Khaimah,
United Arab Emirates
Phone +971 7 2034 700

United Kingdom

KWC DVS Ltd - Northern Office
Barlborough S43 4PZ
Phone +44 1246 450 255

KWC DVS Ltd - Southern Office
Paignton TQ4 7TW
Phone +44 1803 529 021

EAST EUROPE

Bosnia Herzegovina
Bulgaria | Croatia
Hungary | Latvia
Lithuania | Romania
Russia | Serbia | Slovakia
Slovenia | Ukraine

KWC Aquarotter GmbH
14974 Ludwigsfelde, Germany
Phone +49 3378 818 261

SCANDINAVIA & ESTONIA

Finland | Sweden | Norway
Denmark | Estonia

KWC Nordics Oy
76850 Naarajärvi, Finland
Phone +358 15 34 111

OTHER COUNTRIES

KWC Austria GmbH
6971 Hard, Austria
Phone +43 5574 6735 0

