

F5

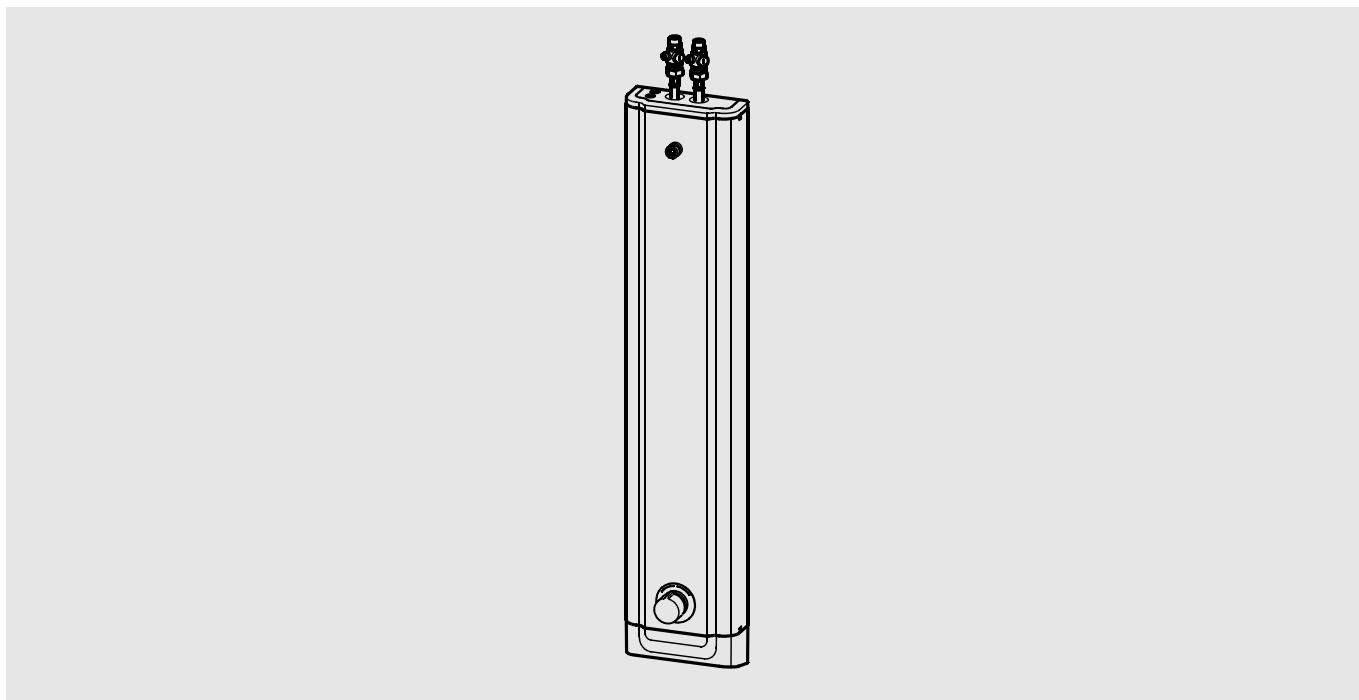

F5SM2020
2030054248

DE	Montage- und Betriebsanleitung	Duschpaneel Edelstahl
EN	Installation and operating instructions	Shower panel stainless steel
FR	Notice de montage et de mise en service	Panneau de douche en acier inox
ES	Instrucciones de montaje y servicio	Panel de ducha de acero inoxidable
IT	Istruzioni per il montaggio e l'uso	Pannello doccia in acciaio inox
NL	Montage- en bedrijfsinstructies	douchepaneel roestvrij staal
PL	Instrukcja montażu i obsługi	Panel natryskowy stal szlachetna
SV	Monterings- och driftinstruktion	Duschpanel rostfritt stål
CS	Návod pro montáž a provoz	Sprchový panel z ušlechtilé oceli
FI	Asennus- ja käyttöohje	Suihkupaneeli ruostumaton teräs
RU	Инструкция по монтажу и вводу в эксплуатацию	

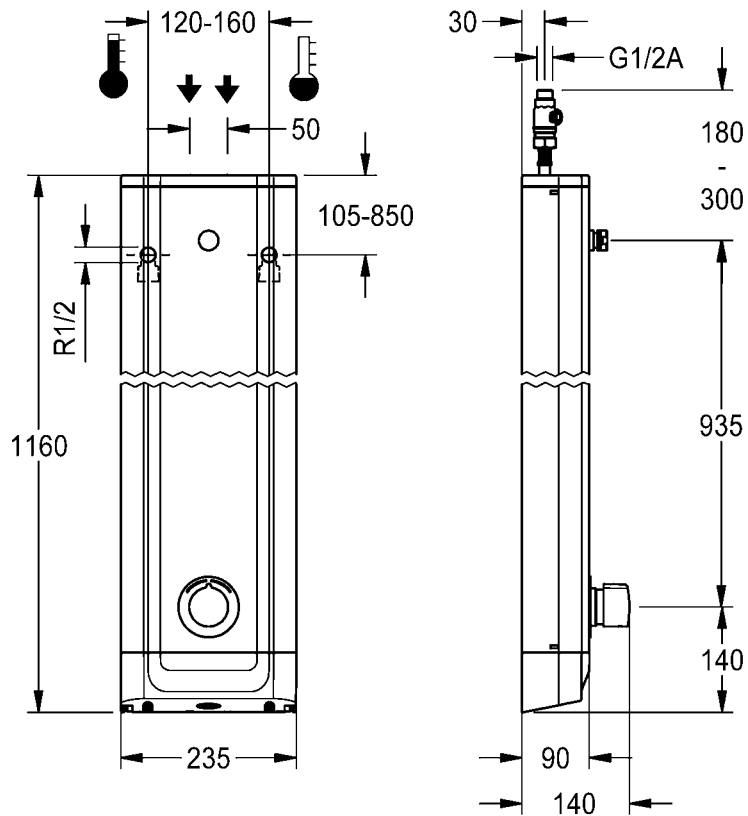
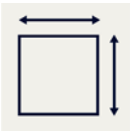
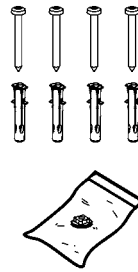
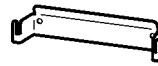
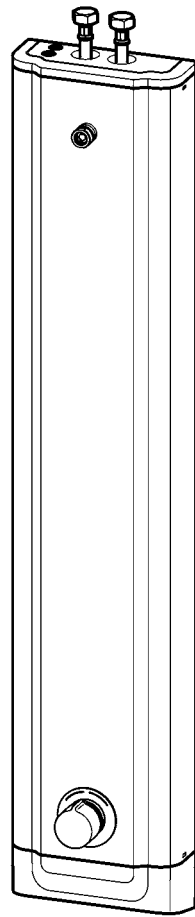

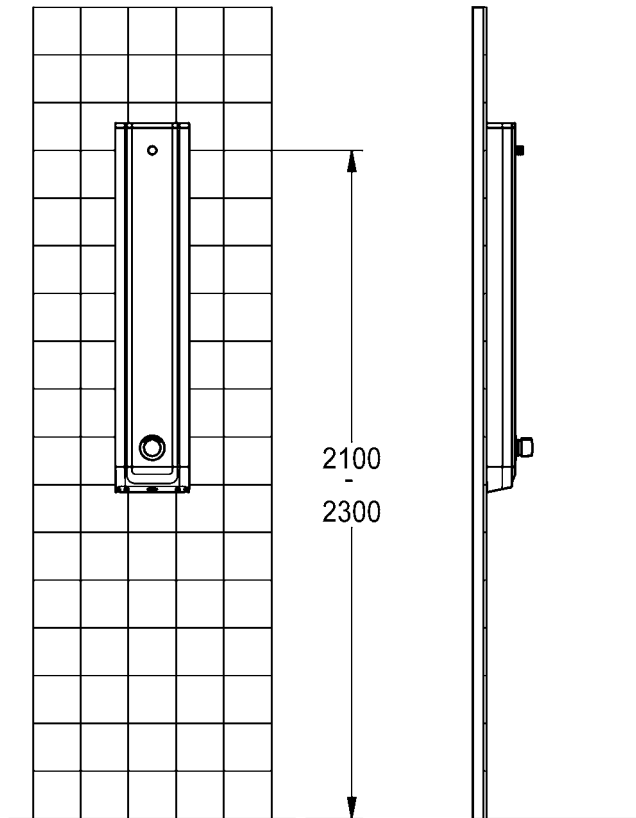

EN Installation and operating instructions

Important notes

- ▶ Before installing flush piping system!
- ▶ Set the temperature stop after assembly has been completed.
- ▶ The fitting must be operated only with original mesh filters and return flow inhibitors!
- ▶ The fitting must be checked and maintained at regular intervals depending on the water quality and in accordance with the local conditions, and rules and regulations applicable at the site.
- ▶ The shower head must be ordered separately.

Technical data

- ▶ Minimum flow pressure 1.5 bar
- ▶ Maximum operating pressure 10 bar
- ▶ Recommended flow pressure 3 bar
- ▶ Volume flow at 3 bar flow pressure 9 l/min
- ▶ Flow time at 38 °C 5-35 s, adjustable

DE Montage- und Betriebsanleitung

Wichtige Hinweise

- ▶ Vor Installation Rohrleitungen spülen!
- ▶ Nach erfolgter Montage den Temperaturanschlag einstellen.
- ▶ Armatur nur mit original Rückflussverhinderern und Sieben betreiben!
- ▶ In Abhängigkeit von der Wasserqualität, den örtlichen Gegebenheiten und den vor Ort geltenden Bestimmungen die Armatur in regelmäßigen Abständen prüfen und warten.
- ▶ Der Duschkopf muss separat bestellt werden.

Technische Daten

- ▶ Mindestfließdruck 1,5 bar
- ▶ Maximaler Betriebsdruck 10 bar
- ▶ Empfohlener Fließdruck 3 bar
- ▶ Volumenstrom bei 3 bar Fließdruck 9 l/min
- ▶ Fließzeit bei 38 °C 5-35 s, einstellbar

PL

Instrukcja montażu i obsługi

Ważne wskazówki

- ▶ Przed instalacją przepłukać rury!
- ▶ Po przeprowadzeniu montażu ustawić ograniczenie temperatury.
- ▶ Armatury należy używać wyłącznie z oryginalnymi sitkami i zaworami zwrotnymi!
- ▶ Armaturę należy poddawać regularnej kontroli i konserwacji w zależności od jakości wody, warunków lokalnych i obowiązujących przepisów.
- ▶ Głowicę prysznicową należy zamawiać oddzielnie.

Dane techniczne

- ▶ Minimalne ciśnienie przepływu 1,5 bar
- ▶ Maksymalne ciśnienie robocze 10 barów
- ▶ Zalecane ciśnienie przepływu 3 barów
- ▶ Objętościowe natężenie przepływu przy ciśnieniu 3 barów 9 l/min
- ▶ Czas przepływu w temp. 38 °C 5-35 s, z możliwością ustawienia

FR

Notice de montage et de mise en service

Remarques importantes

- ▶ Rincer les conduites avant d'installer !
- ▶ Régler la butée de température après le montage.
- ▶ Ne faire fonctionner la robinetterie qu'avec les filtres et clapets de non retour d'origine !
- ▶ En fonction de la qualité de l'eau, ainsi que des conditions et des dispositions locales, il convient de contrôler et d'entretenir la robinetterie à intervalles réguliers.
- ▶ Le pommeau de douche doit être commandé séparément.

Données techniques

- ▶ Pression dynamique minimale 1,5 bar
- ▶ Pression de service maximale 10 bars
- ▶ Pression dynamique recommandée 3 bars
- ▶ Débit volumique pour 3 bars de pression dynamique 9 l/min
- ▶ Temps d'écoulement à 38 °C 5-35 s, réglable

SV

Monterings- och driftinstruktion

Viktiga informationer

- ▶ Spola igenom rörledningarna före installation!
- ▶ Ställ in temperaturstoppet efter installationen.
- ▶ Använd armaturen endast med originalsilar och originalåterflödesförhindrare!
- ▶ Kontrollera och serva armaturen med intervaller som bestäms av vattenkvaliteten samt de lokala förhållandena och de bestämmelser som gäller där.
- ▶ Duschmunstycket måste beställas separat.

Tekniska data

- ▶ Minsta hydrauliska tryck 1,5 bar
- ▶ Maximalt driftryck 10 bar
- ▶ Rekommenderat hydrauliskt tryck 3 bar
- ▶ Volymström vid 3 bar hydrauliskt tryck 9 l/min
- ▶ Flytförmåga vid 38 °C 5-35 s, inställbar

CS

Návod pro montáž a provoz

Důležité pokyny

- ▶ Před instalací potrubí propláchněte!
- ▶ Po montáži nastavte teplotní limit.
- ▶ Provozovat armaturu jen s originálními sítky a zařízeními proti zpětnému toku!
- ▶ V závislosti na kvalitě vody, místních podmínkách a předpisech platných v místě instalace je nutné provádět v pravidelných intervalech kontrolu a údržbu armatury.
- ▶ Sprchovou hlavici je nutno objednat zvlášť.

Technické údaje

- ▶ Minimální průtočný tlak 1,5 bar
- ▶ Maximální provozní tlak 10 bar
- ▶ Doporučený průtočný tlak 3 bar
- ▶ Průtok při průtočném tlaku 3 bar 9 l/min
- ▶ Doba průtoku při 38 °C 5-35 s, nastavitelná

ES

Instrucciones de montaje y servicio

Indicaciones importantes

- ▶ ¡Enjuagar las tuberías antes de instalar!
- ▶ Tras finalizar el montaje, ajustar el tope de temperatura.
- ▶ ¡La grifería debe hacerse funcionar únicamente con los tamices y las válvulas antiretorno originales!
- ▶ En función de la calidad del agua, las condiciones locales y la legislación vigente, realizar las inspecciones y el mantenimiento de la grifería a intervalos regulares.
- ▶ El cabezal de ducha debe pedirse por separado.

Datos técnicos

- ▶ Presión mínima de flujo 1,5 bar
- ▶ Presión máxima de servicio 10 bares
- ▶ Presión de flujo recomendada 3 bares
- ▶ Flujo volumétrico con 3 bares de presión de flujo 9 l/min
- ▶ Tiempo de flujo a 38 °C 5-35 s, ajustable

FI

Asennus- ja käyttöohje

Tärkeitä ohjeita

- ▶ Huuhtele putkijohdot ennen asennusta!
- ▶ Kun asennus on tehty, säädä lämpötilarajoin.
- ▶ Käytä varusteet vain alkuperäisten sihtien ja takaisinvirtauksen eston kanssa!
- ▶ Hana tulee tarkistaa ja huoltaa säännöllisin väliajoin veden laadusta, paikallisista oloista ja paikalla voimassa olevista määräyksistä riippuen.
- ▶ Suihkupää on tilattava erikseen.

Tekniset tiedot

- ▶ Vähimmäisvirtauspaine 1,5 bar
- ▶ Suurin käyttöpaine 10 bar
- ▶ Suositeltava virtauspaine 3 bar
- ▶ Tilavuusvirta 3 barin virtauspaineella 9 l/min
- ▶ Virtausaika 38 °C lämpötilassa 5-35 s, säädettävissä

IT

Istruzioni per il montaggio e l'uso

Avvertenze importanti

- ▶ Sciacquare le tubazioni prima di installare!
- ▶ A montaggio avvenuto impostare il blocco temperatura.
- ▶ Utilizzare la rubinetteria esclusivamente con i filtri e le valvole antiriflusso originali!
- ▶ Controllare e sottoporre a manutenzione l'apparecchio ad intervalli regolari, in funzione della qualità dell'acqua, delle caratteristiche locali e delle vigenti disposizioni locali.
- ▶ La doccetta va ordinata a parte.

RU

Инструкция по монтажу и вводу в эксплуатацию

Важные указания

- ▶ Перед инсталляцией промыть трубки!
- ▶ После произведенного монтажа настроить температурный упор.
- ▶ Эксплуатировать арматуру только с оригинальными фильтрами и клапанами обратного течения!
- ▶ Арматуру необходимо регулярно чистить и обслуживать в зависимости от качества воды, местных условий и действующих в месте эксплуатации предписаний.
- ▶ Душевая головка заказывается отдельно.

Specifiche tecniche

- ▶ Pressione idraulica min. 1,5 bar
- ▶ Pressione di esercizio max. 10 bar
- ▶ Pressione idraulica consigliata 3 bar
- ▶ Portata volumetrica a 3 bar di pressione idraulica 9 l/min
- ▶ Durata di flusso a 38 °C 5-35 s, impostabile

Технические характеристики

- ▶ Минимальный гидравлический напор 1,5 бар
- ▶ Максимальное рабочее давление 10 бар
- ▶ Рекомендуемый гидравлический напор 3 бар
- ▶ Объёмный расход при гидравлическом напоре 3 бар 9 л/мин
- ▶ Продолжительность истечения при 38 °C 5-35 s, регулируемое

NL

Montage- en bedrijfsinstructies

Belangrijke aanwijzingen

- ▶ Voor installatie buisleidingen spoelen!
- ▶ Na de montage de temperatuurbegrenzing instellen.
- ▶ Armatuur alleen met originele zeven gebruiken!
- ▶ Afhankelijk van de waterkwaliteit, de plaatselijke omstandigheden en de plaatselijke voorschriften de armatuur regelmatig controleren en onderhouden.
- ▶ De douchekop moet apart worden besteld.

Technische gegevens

- ▶ Minimale dynamische druk 1,5 bar
- ▶ Maximale werkdruk 10 bar
- ▶ Aanbevolen dynamische druk 3 bar
- ▶ Volumestroom bij 3 bar dynamische druk 9 l/min
- ▶ Stromingstijd bij 38 °C 5-35 s, instelbaar



1. Montage

EN Installation
FR Montage
ES Montaje
IT Montaggio

NL Montage
PL Montaż
SV Montering

CS Montáž
FI Asennus
RU Монтаж

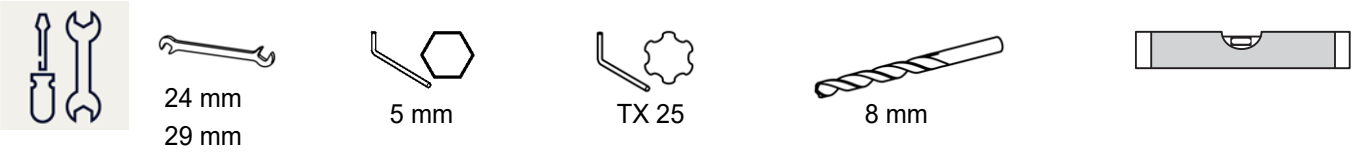

1

1

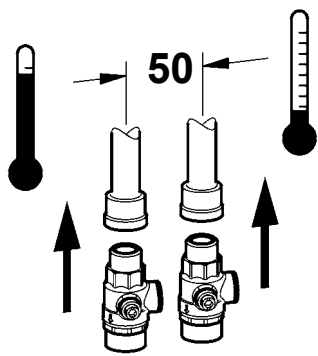

2

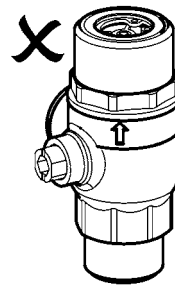
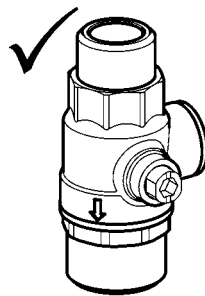
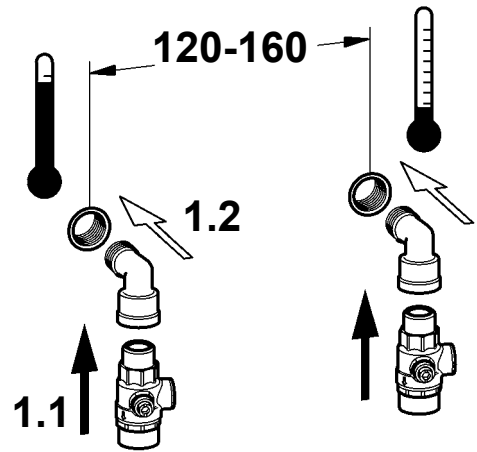

2

2.1

2.2

2.3

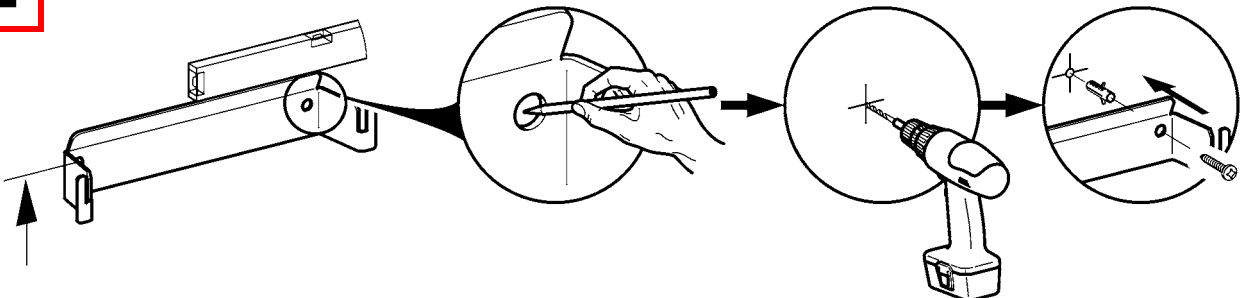

2,14 m - 2,34 m

5

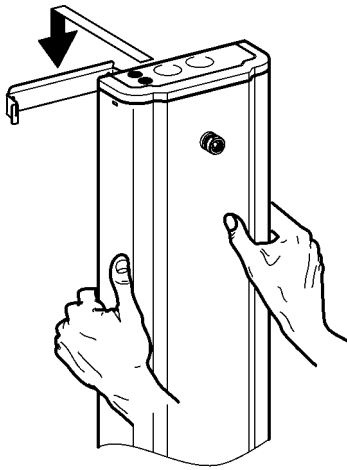

6

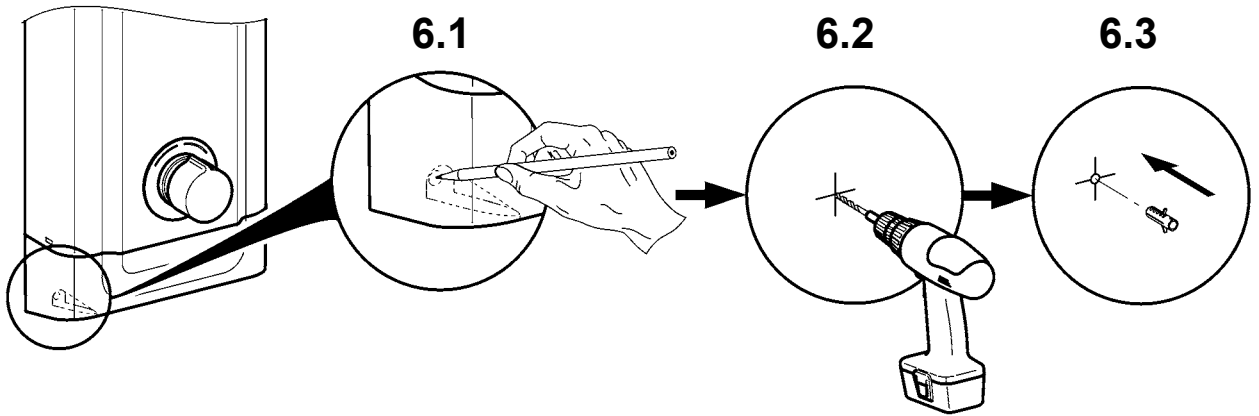

7

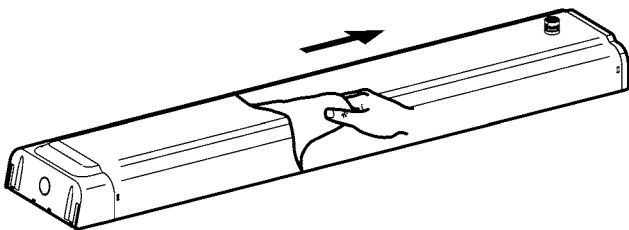

8

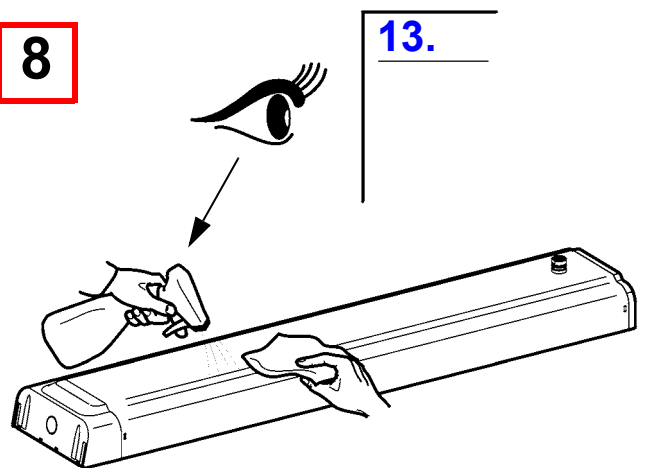

9

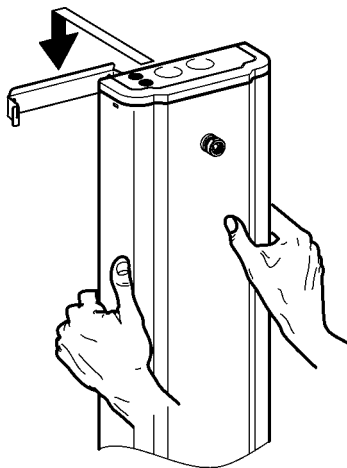

10

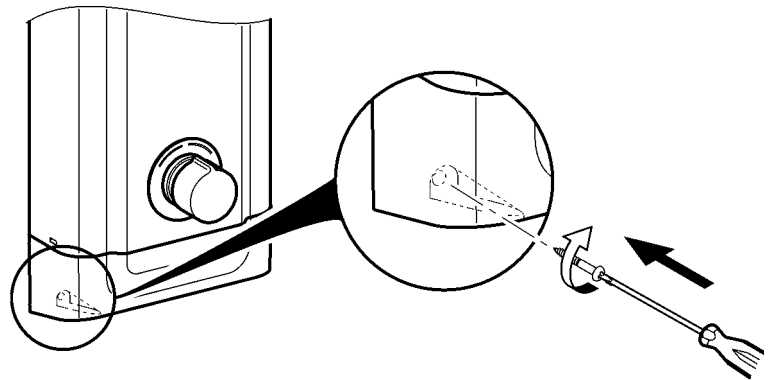

11

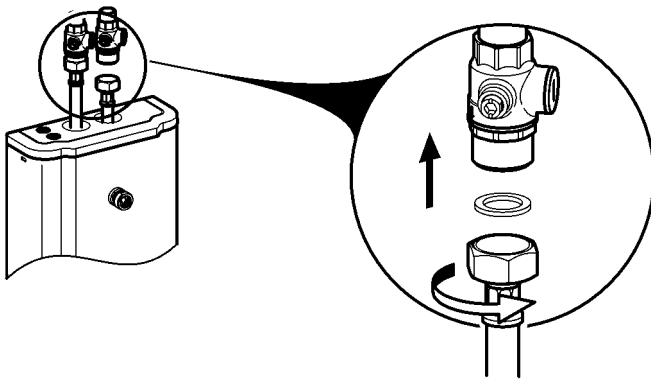

12

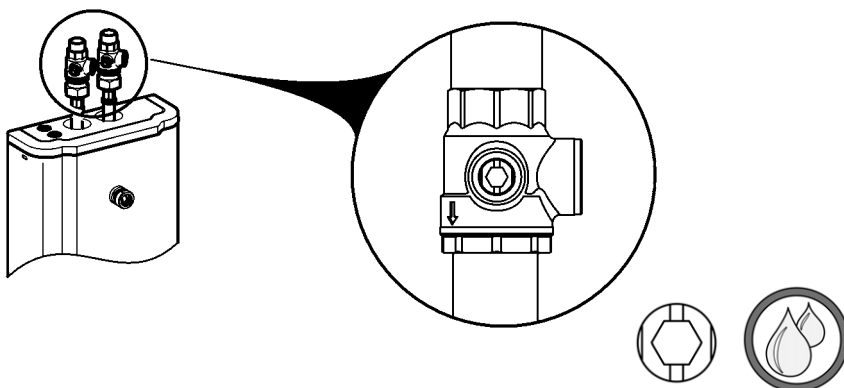

13

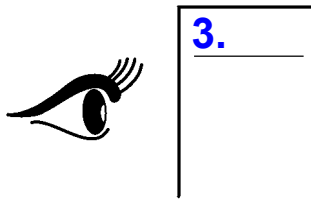

14

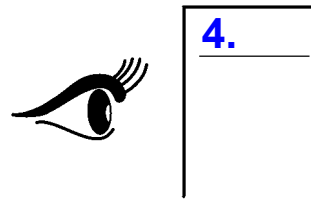

15

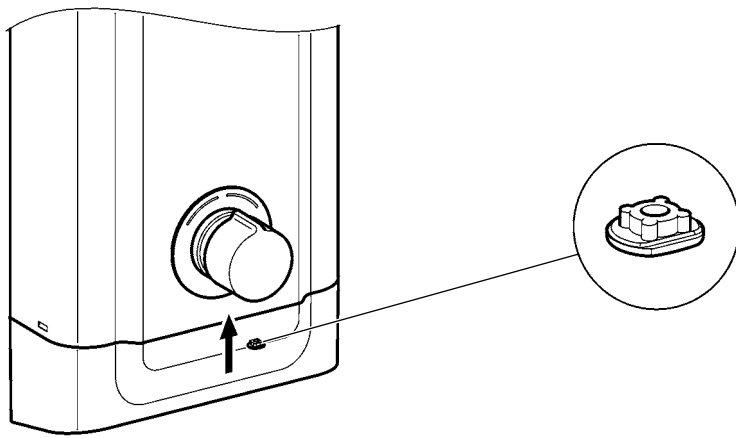

2. Funktion

EN Function
FR Fonctionnement
ES Función
IT Funzionamento

NL Werking
PL Funkcja
SV Funktion

CS Funkce
FI Toiminto
RU Функционирование

1

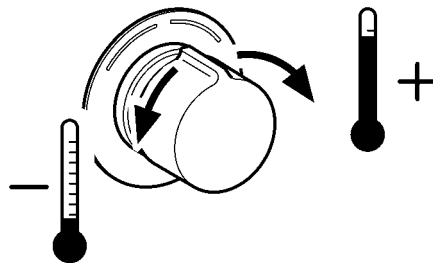
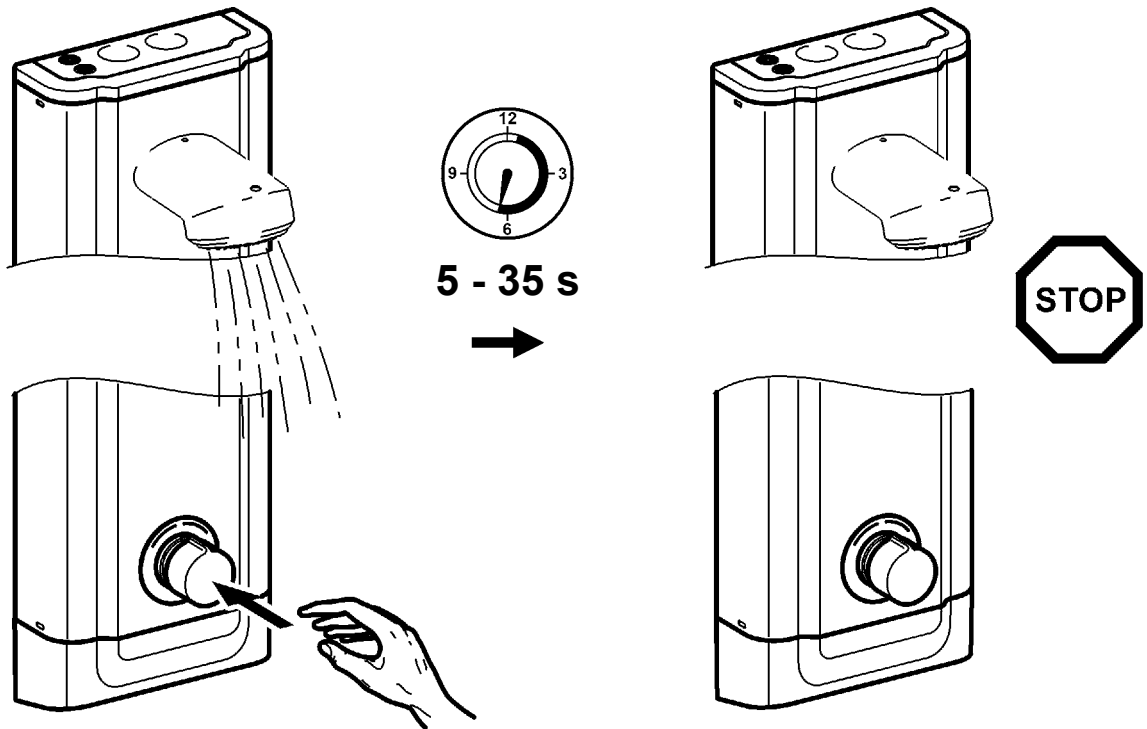

3. Fließzeit einstellen

EN Adjust flow duration

NL Stroomingstijd instellen

CS Nastavit dobu průtoku

FR Régler la durée d'écoulement

PL Ustawić czas przepływu

FI Aseta virtausaika

ES Ajustar el tiempo de flujo

SV Ställa in flytförmågan

RU Регулировка времени истечения

IT Impostazione della durata di flusso

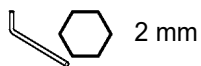

1

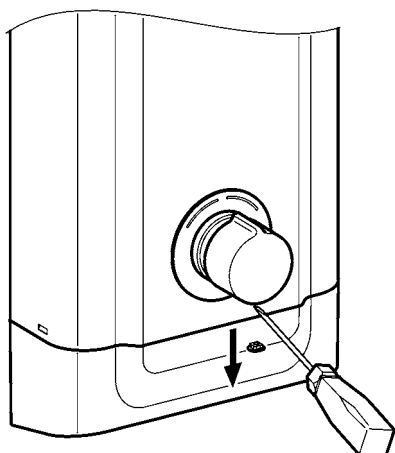

2

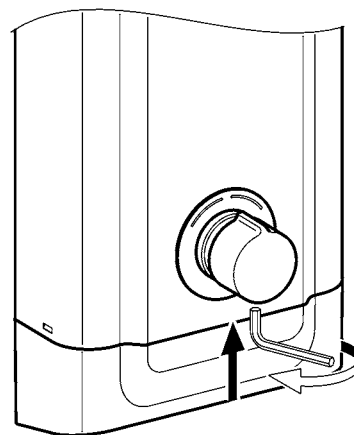

3

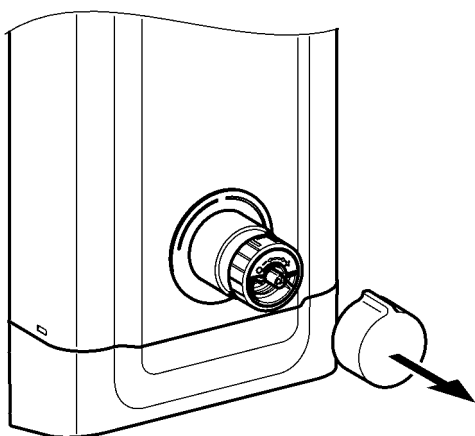

4

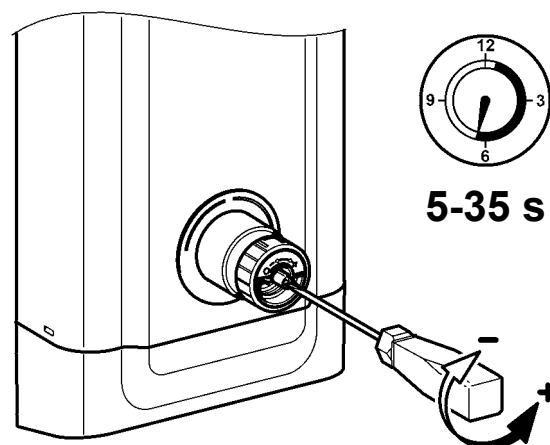

5

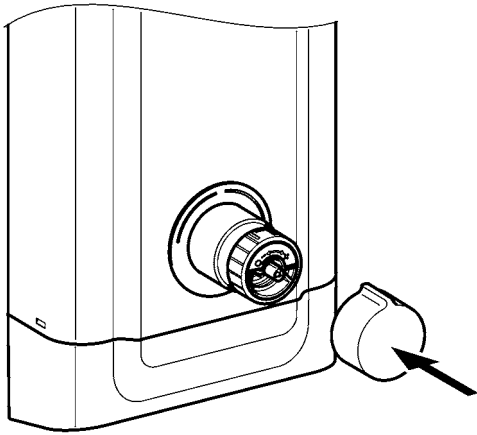

6

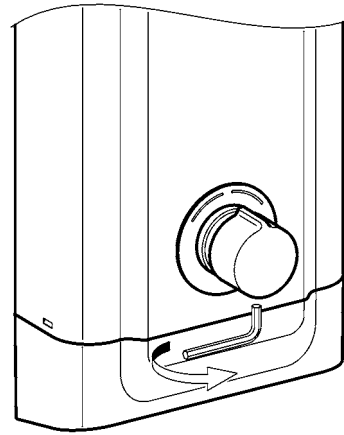

7

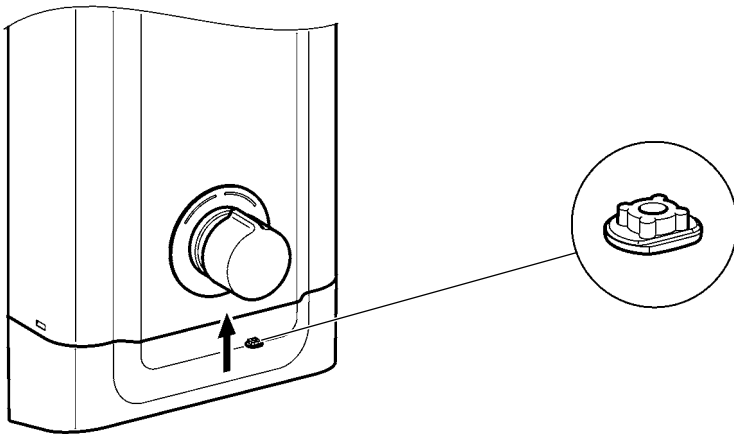

4. Temperaturanschlag einstellen

EN Setting the temperature stop

NL Temperatuurbe grenzing instellen

CS Nastavení teplotního limitu

FR Réglage de la butée de température

PL Ustawienie ograniczenia temperatury

FI Lämpötilarajoituksen säätäminen

ES Ajuste del tope de temperatura

SV Ställa in temperaturstoppet

RU Настройка температурного упора

IT Impostazione del blocco temperatura

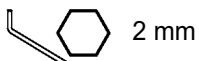

1

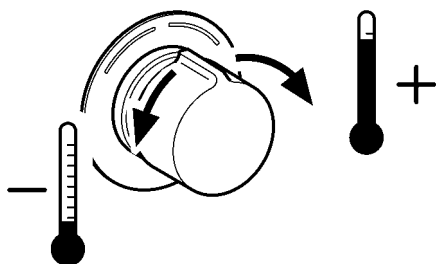

2

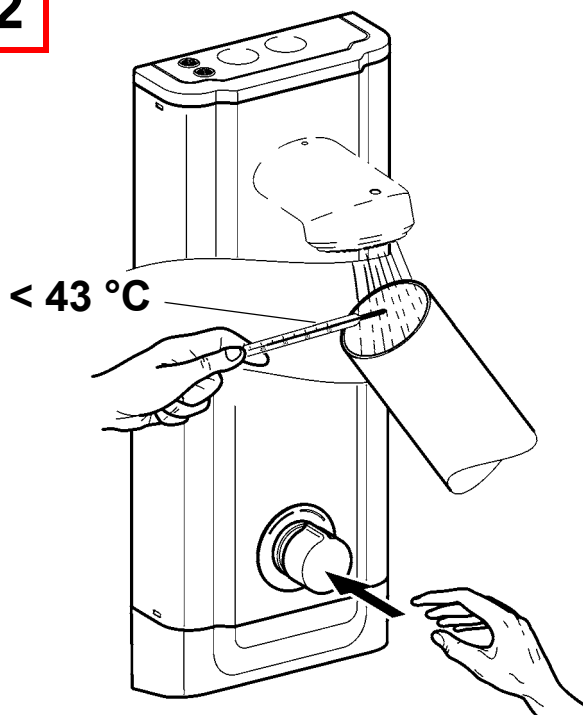

3

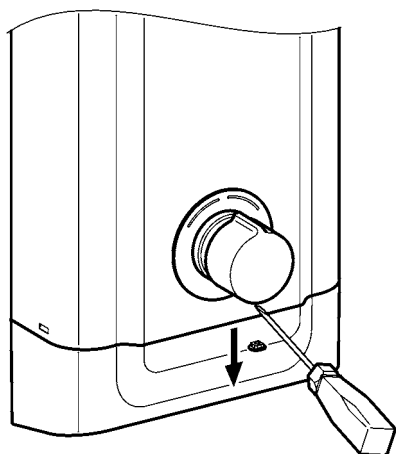

4

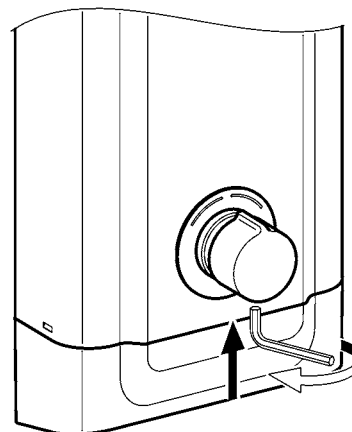

5

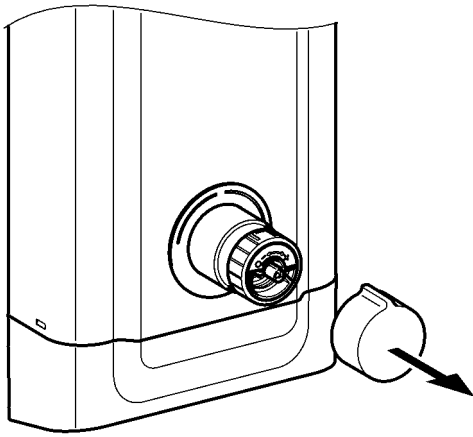

6

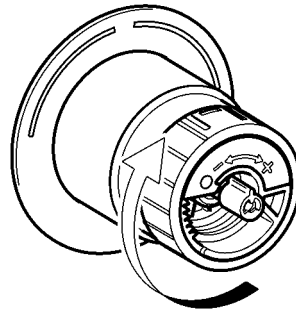

7

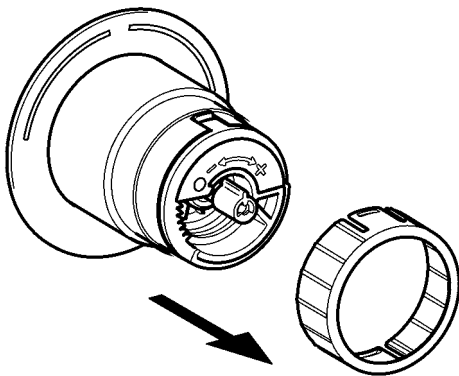

8

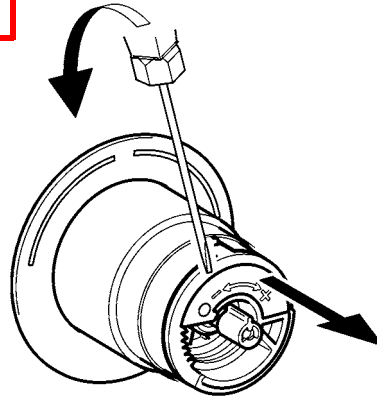

9

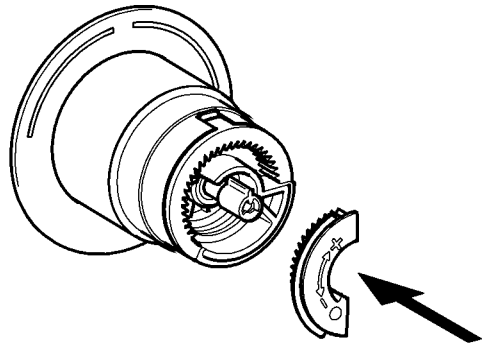
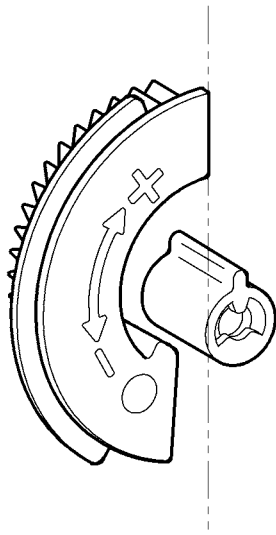

10

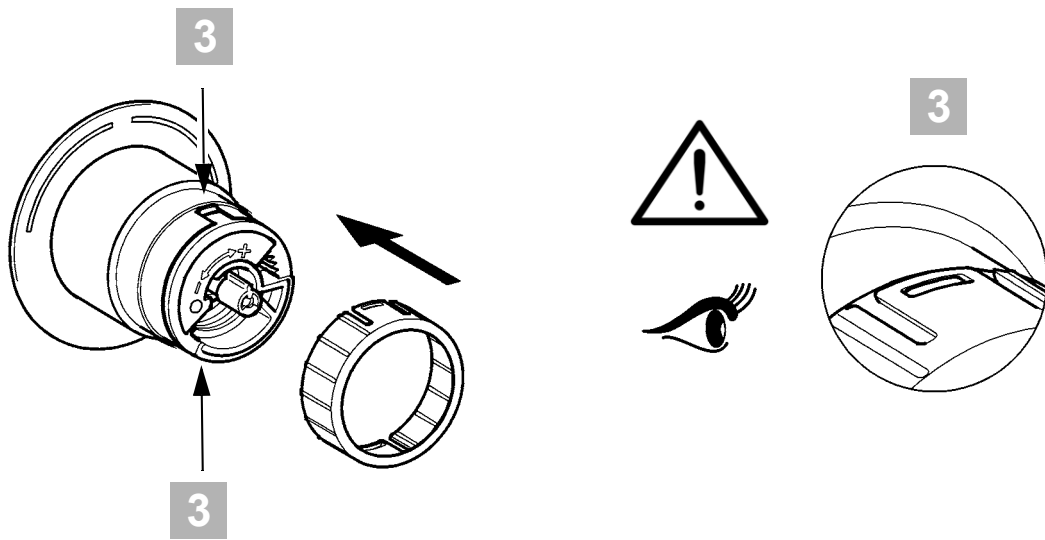

11

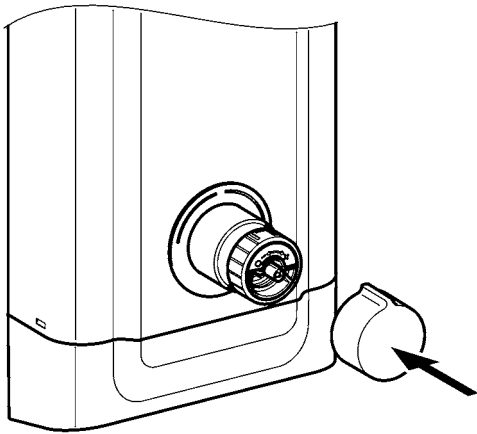

12

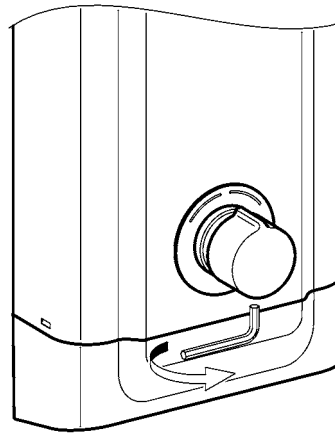

13

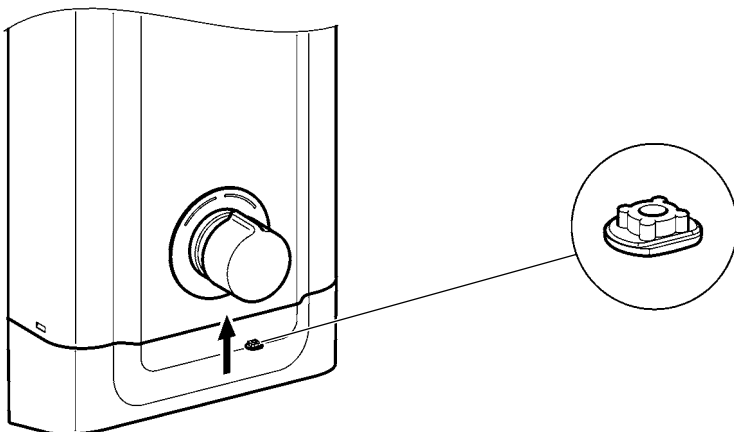

5. Wartung

EN Maintenance
FR Maintenance
ES Mantenimiento
IT Manutenzione

NL Onderhoud
PL Konserwacja
SV Underhåll

CS Varování
FI Huolto
RU Техническое обслуживание



8.

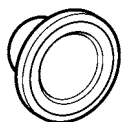

9.

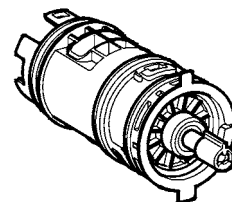

10.

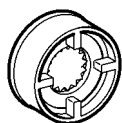

11.

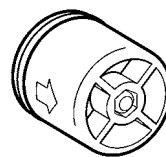

6. Paneel abnehmen

EN Removing the panel

FR Retirer le panneau

ES Retirar el panel

IT Rimozione del pannello

NL Paneel weghalen

PL Zdejnowanie panelu

SV Ta bort panelen

CS Demontujte panel

FI Paneelin irrottaminen

RU Снятие панели

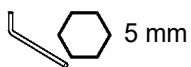

1

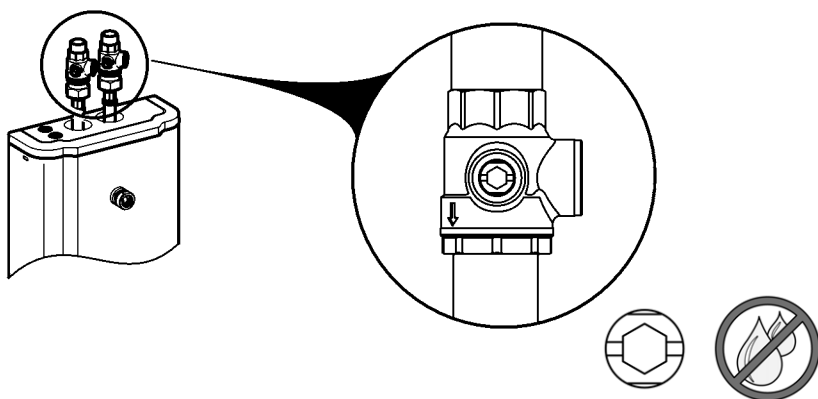

2

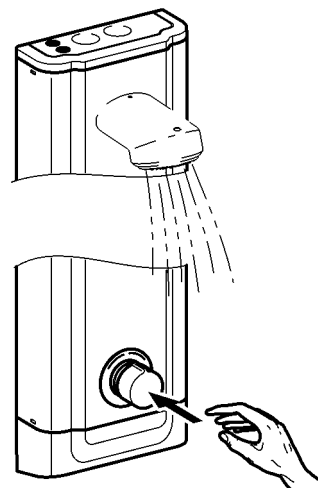

3

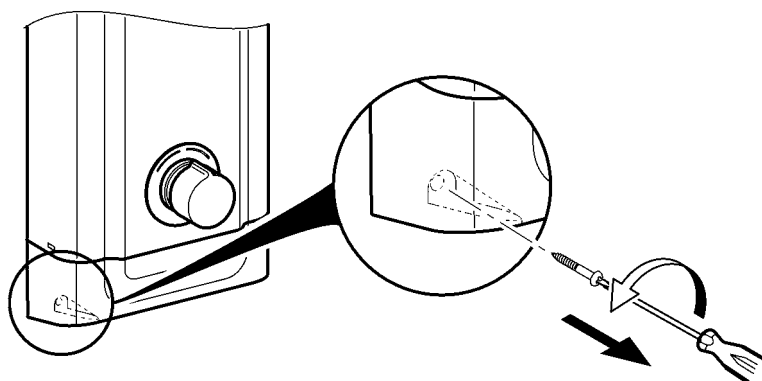

4

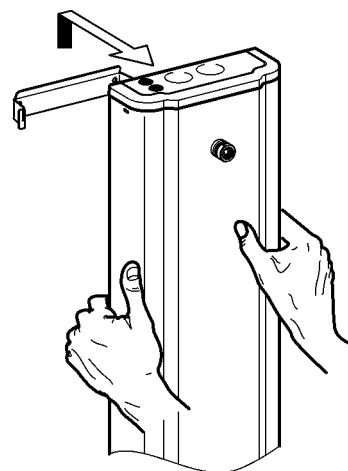

5

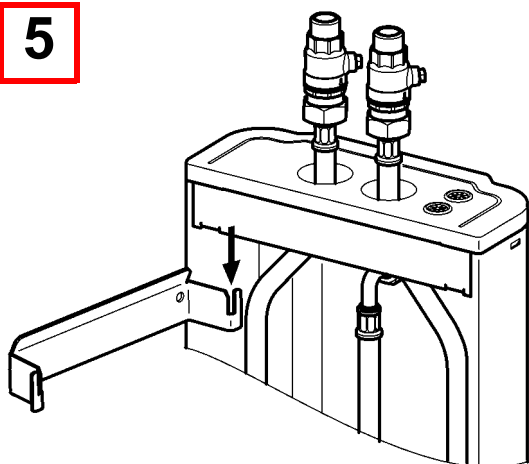

7. Paneel montieren

EN Mounting the panel

FR Monter le panneau

ES Montar el panel

IT Montaggio del pannello

NL Paneel monteren

PL Montaż panelu

SV Montera panelen

CS Namontujte panel

FI Paneelin asentaminen

RU Монтаж панели

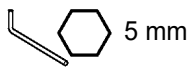

1

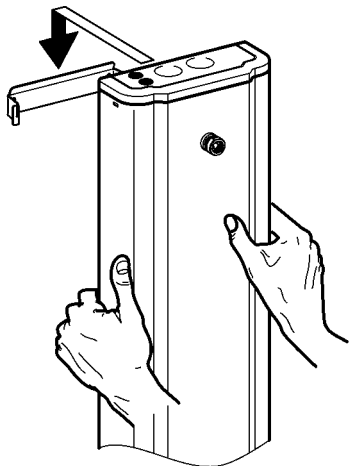

2

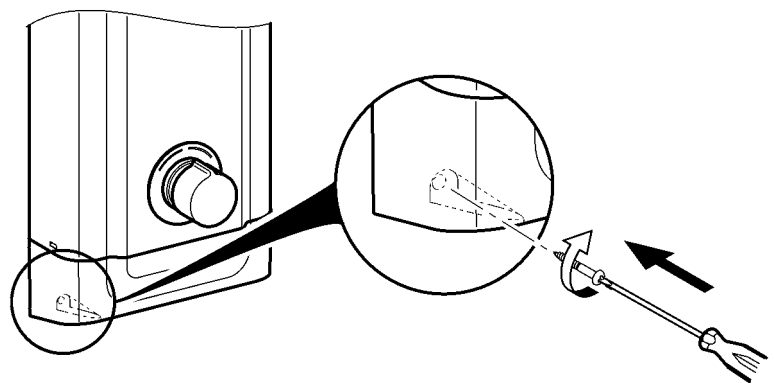

3

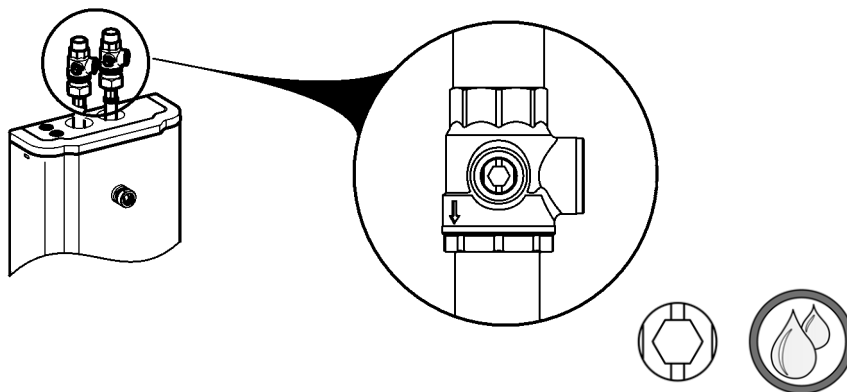

8. Siebe wechseln

EN Replace the filters

FR Remplacement les filtres

ES Cambiar los tamices

IT Sostituire i filtri

NL Zeven vervangen

PL Wymiana sit

SV Byt filter

CS Vyměňte síto

FI Siivilän vaihto

RU Сменить сеточки

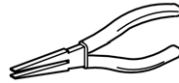
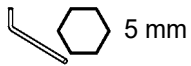

1

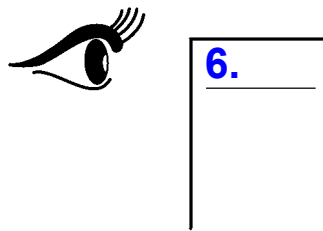

2

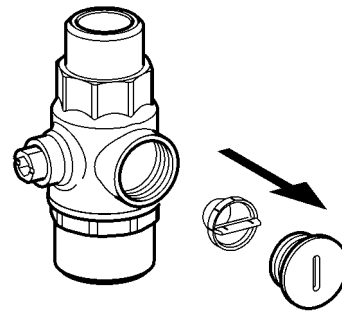

3

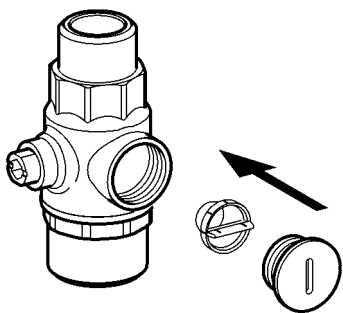

4

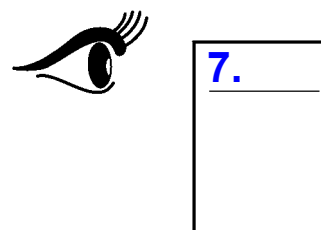

9. Selbstschluss-Kartusche wechseln

EN	Replace self-closing cartridge	PL	Wymienić wkład samozamykający
FR	Remplacement de la cartouche mélangeuse à fermeture automatique	SV	Byta självstängande patron
ES	Cambio de cartucho con cierre automático	CS	Výměna kartuše vodovodní baterie
IT	Sostituzione della cartuccia a chiusura automatica	FI	Itsesulkeutuvan panoksen vaihtaminen
NL	Zelfsluitende patroon vervangen	RU	Замена самоблокирующегося картриджа

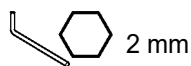

1

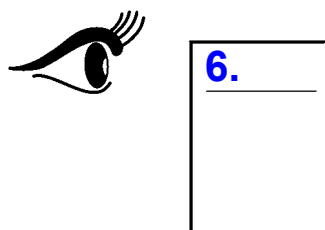

2

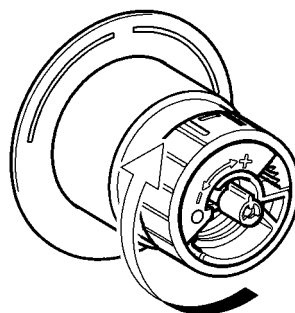

3

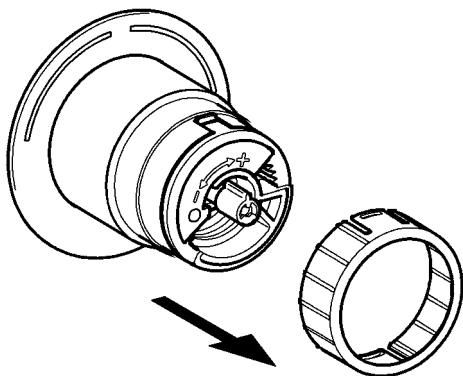

4

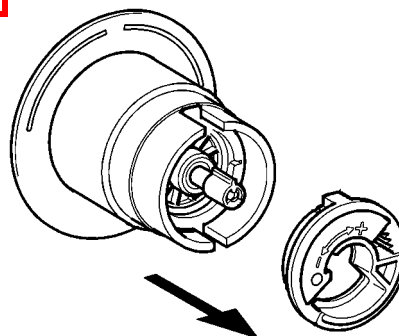

5

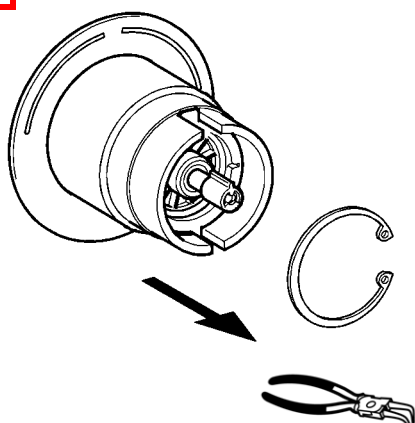

6

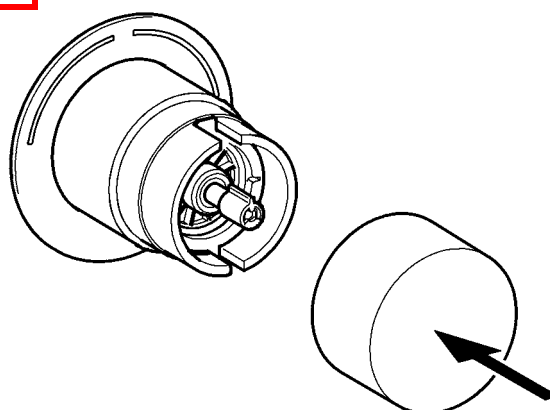

7

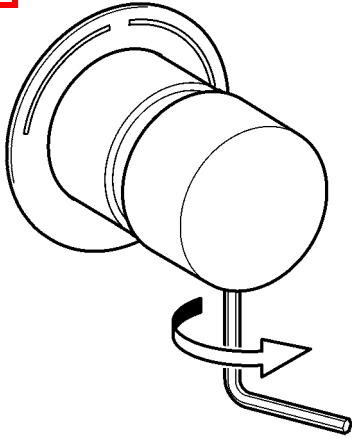

8

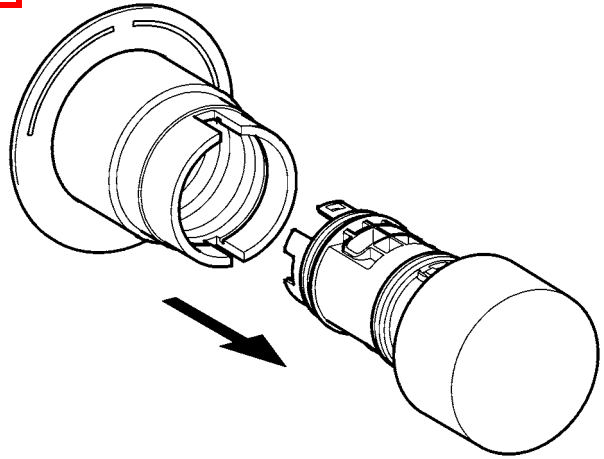

9

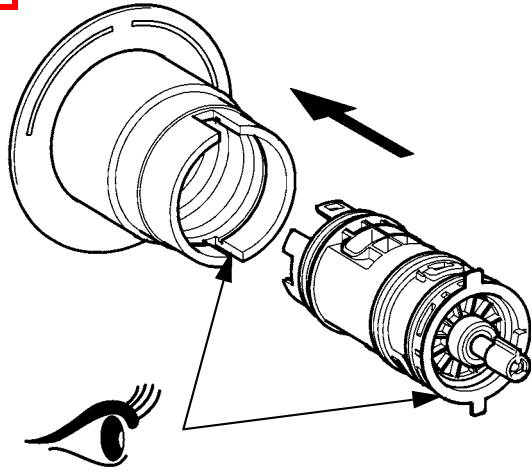

10

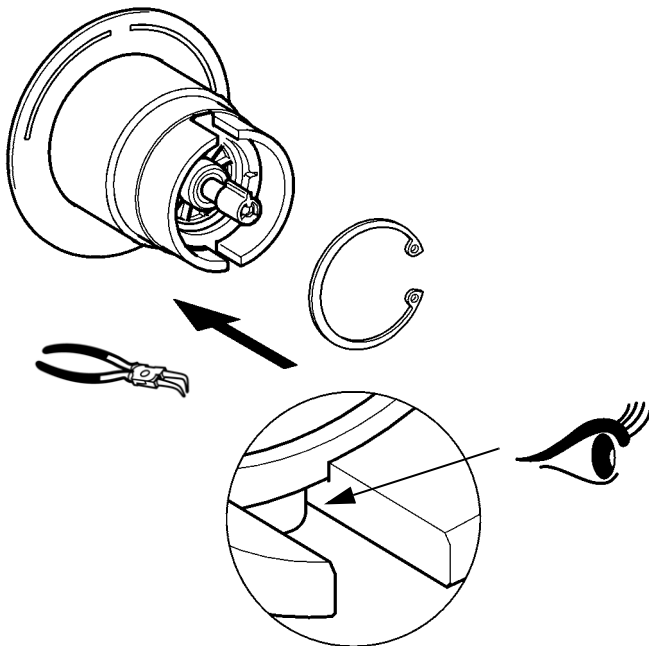

11

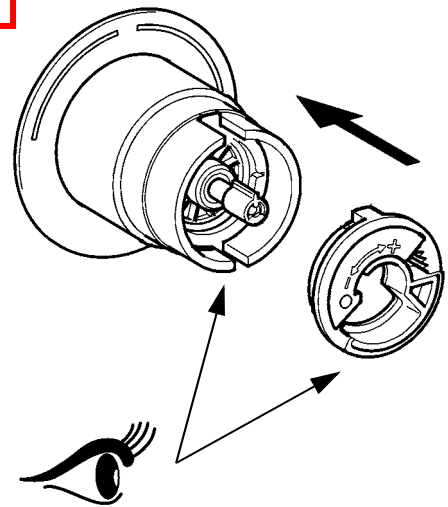

12

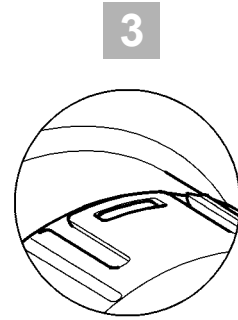
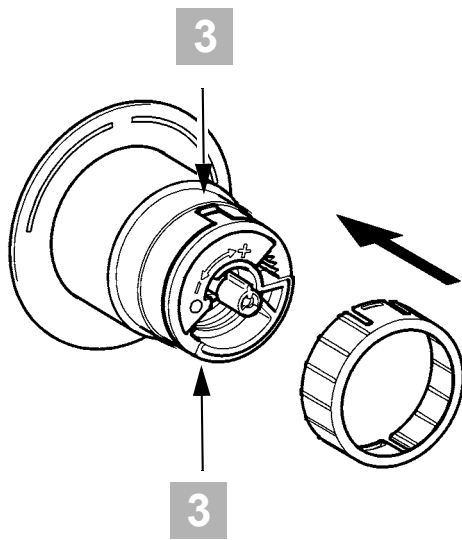

13



3.

14



7.

10. Durchflussmengenregler wechseln

EN Replace the flow rate regulator	NL Debietregelaar vervangen	CS Byt flödesregulator
FR Remplacement du régulateur de débit	PL Wymiana regulatora wielkości przepływu	FI Lämpivirtausmäärän säätimen vaihto
ES Cambiar el regulador volumétrico de paso	SV Byt flödesregulator	RU Заменить регулятор расхода
IT Sostituire il regolatore di portata		

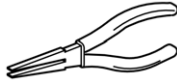

1



6.

2

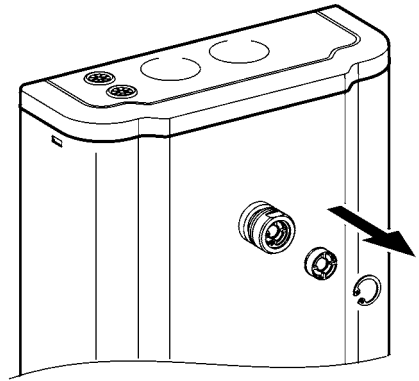

3

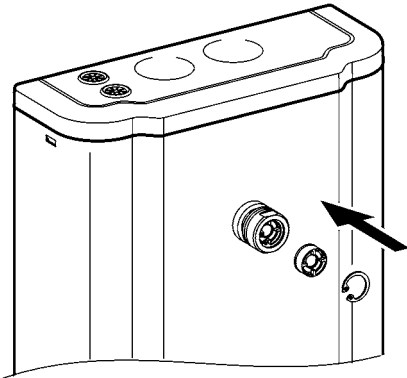

4



7.

11. Rückflussverhinderer wechseln

EN Replace the return flow inhibitor	NL Terugstroomklep vervangen	CS Vyměňte zábranu zpětného průtoku
FR Remplacement du clapet de non-retour	PL Wymiana zaworu zwrotnego	FI Paluuvirtausestäjän vaihto
ES Reemplazar la válvula antiretorno	SV Byt återströmningsskydd	RU Заменить клапан обратного течения
IT Sostituire la valvola antiriflusso		

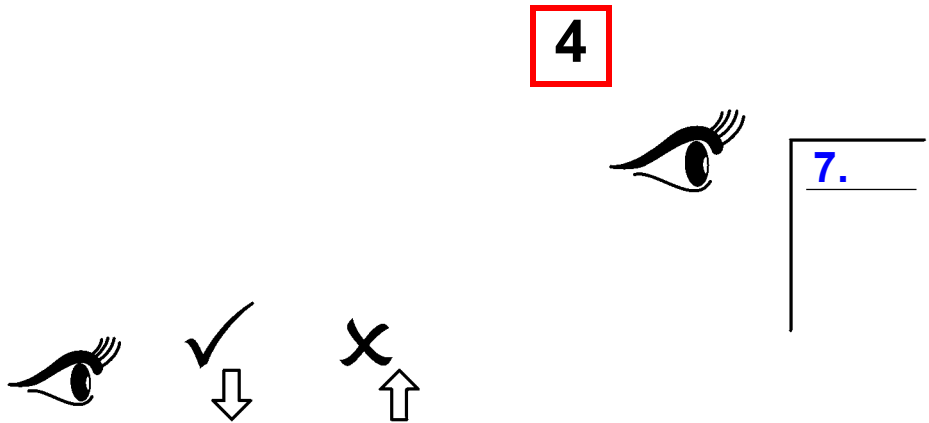
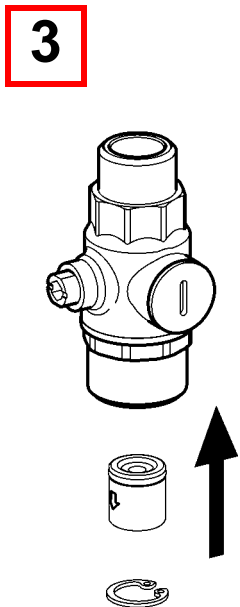
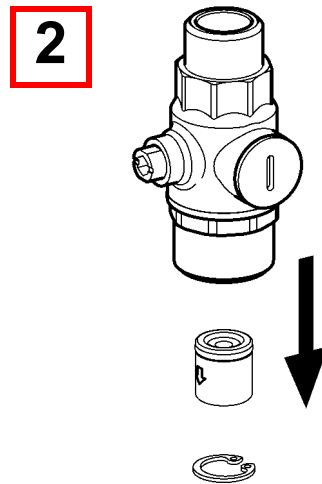
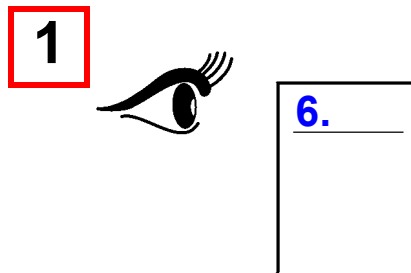

12. Ersatzteile

EN Replacement parts
FR Pièces de rechange
ES Piezas de recambio
IT Pezzi di ricambio

NL Reserveonderdelen
PL Części zamienne
SV Reservdelar

CS Náhradní díly
FI Varaosat
RU Запчасти

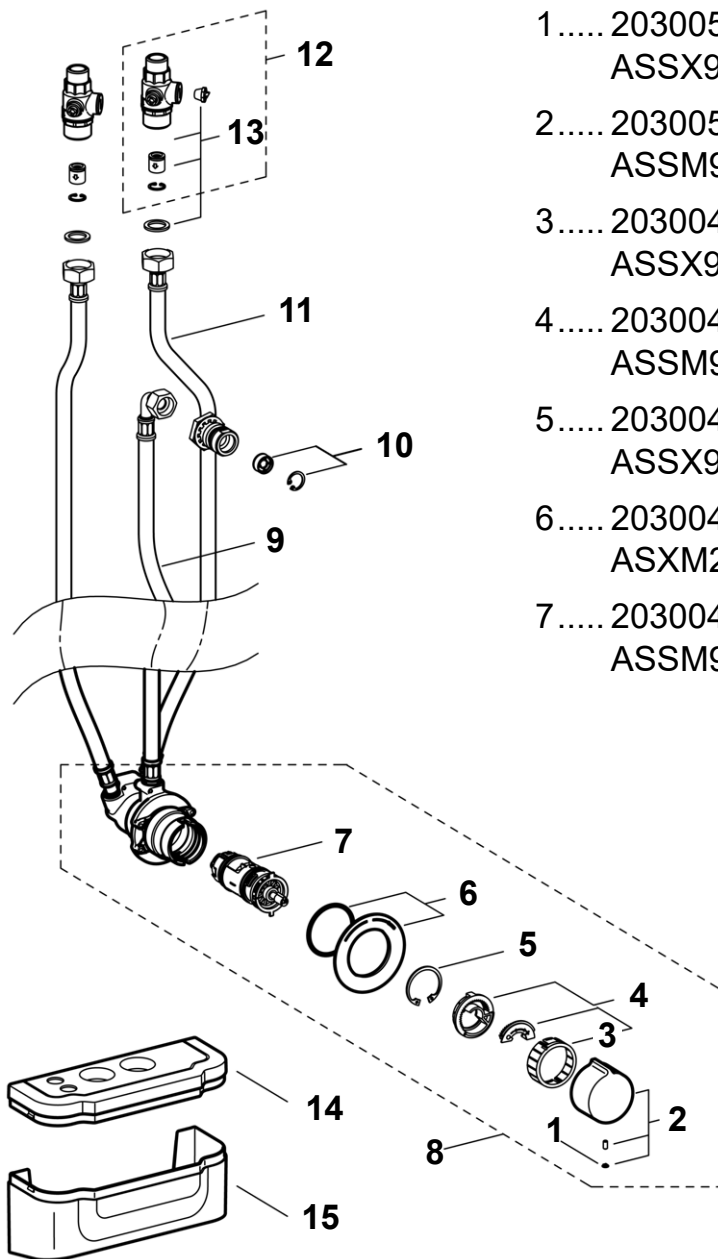

1..... 2030053006 ^{c)} ASSX9004	8 2030062702 ASSM2005
2..... 2030050753 ASSM9004	9 2030060323 ASXX2008
3..... 2030048356 ASSX9002	10 .. 9 l/min: 2000104782 ESHHE0001
4..... 2030046189 ASSM9002	11... 2030060321 ASXX2007
5..... 2030048357 ^{b)} ASSX9003	12 .. 2030060314 ASXX2005
6..... 2030045510 ASXM2003	13 .. 2030060824 ^{a)} ASXX2006
7..... 2030046185 ASSM9001	14 .. 2030062350 ASXX2013
	15 .. 2030062351 ASXX2014

EN a) 2 pieces
b) 5 pieces
c) 10 pieces

ES a) 2 piezas
b) 5 piezas
c) 10 piezas

PL a) 2 sztuk
b) 5 sztuk
c) 10 sztuk

FI a) 2 kappaletta
b) 5 kappaletta
c) 10 kappaletta

DE a) 2 Stück
b) 5 Stück
c) 10 Stück

IT a) 2 pezzi
b) 5 pezzi
c) 10 pezzi

SV a) 2 styck
b) 5 styck
c) 10 styck

RU a) 2 штук
b) 5 штук
c) 10 штук

FR a) 2 pièces
b) 5 pièces
c) 10 pièces

NL a) 2 stuk
b) 5 stuk
c) 10 stuk

CS a) 2 kusů
b) 5 kusů
c) 10 kusů

13. Zubehör

EN Accessories
FR Accessoire
ES Accesorios
IT Accessori

NL Toebehoren
PL Akcesoria
SV Tillbehör

CS Příslušenství
FI Lisävarusteet
RU принадлежности

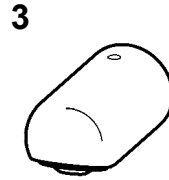
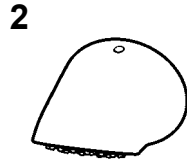
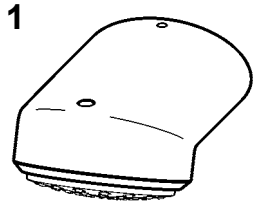

1..... 2030054254
SHAC0011

2..... **19°**
2030054255
SHAS0011

3..... 2030054793
SHMU0011

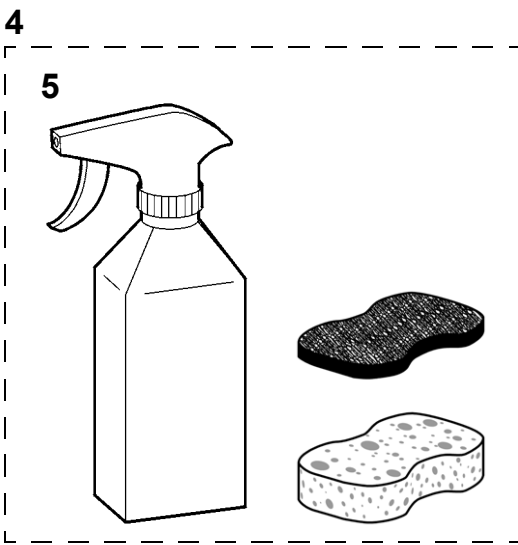

4..... 2000109019
ZWSPL0024

5..... **0,5 l:**
2000105091
ZWSPL0023

6..... **110-170 mm:**
2030057066
ACXX2011

160-250 mm:
2030057067
ACXX2012

240-410 mm:
2030057068
ACXX2013

400-660 mm:
2030057069
ACXX2014

650-960 mm:
2030057070
ACXX2015

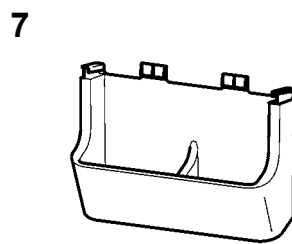
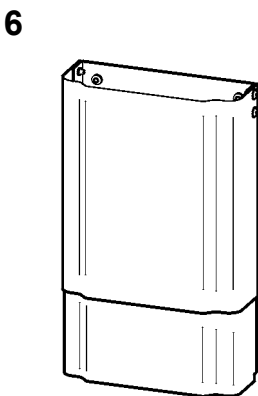

7..... 2030057077
ACXX2021

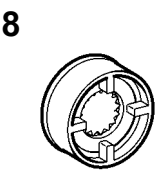

8..... **6 l/min:**
2030027586
ESHHE0004

12 l/min:
2000104783
ESHHE0002

9..... 2030047203
ACXX9003

Australia

PR Kitchen and
Water Systems Pty Ltd
Dandenong South VIC 3175
Phone +61 3 9700 9100

Austria

KWC Austria GmbH
6971 Hard, Austria
Phone +43 5574 6735 0

**Belgium, Netherlands &
Luxembourg**

KWC Aquarotter GmbH
9320 Aalst; Belgium
Phone NL +31 (0) 492 728 224
BE/LU +32 (0) 53 60 31 50

Czech Republic

KWC Aquarotter GmbH
14974 Ludwigsfelde, Germany
Phone +49 3378 818 309

France

KWC Austria GmbH
6971 Hard, Austria
Phone +33 800 909 216

Germany

KWC Aquarotter GmbH
14974 Ludwigsfelde
Phone +49 3378 818 0

Italy

KWC Austria GmbH
6971 Hard, Austria
Numero Verde +39 800 789 233

Middle East

KWC ME LLC Ras Al Khaimah,
United Arab Emirates
Phone +971 7 2034 700

Poland

KWC Aquarotter GmbH
14974 Ludwigsfelde, Germany
Phone +48 58 35 19 700

Spain

KWC Austria GmbH
6971 Hard, Austria
Phone +43 5574 6735 211

Switzerland & Liechtenstein

KWC Group AG
5726 Unterkulm, Switzerland
Phone +41 62 768 69 00

Turkey

KWC ME LLC Ras Al Khaimah,
United Arab Emirates
Phone +971 7 2034 700

United Kingdom

KWC DVS Ltd - Northern Office
Barlborough S43 4PZ
Phone +44 1246 450 255

KWC DVS Ltd - Southern Office
Paignton TQ4 7TW
Phone +44 1803 529 021

EAST EUROPE

Bosnia Herzegovina
Bulgaria | Croatia
Hungary | Latvia
Lithuania | Romania
Russia | Serbia | Slovakia
Slovenia | Ukraine

KWC Aquarotter GmbH
14974 Ludwigsfelde, Germany
Phone +49 3378 818 261

SCANDINAVIA & ESTONIA

Finland | Sweden | Norway
Denmark | Estonia

KWC Nordics Oy
76850 Naarajärvi, Finland
Phone +358 15 34 111

OTHER COUNTRIES

KWC Austria GmbH
6971 Hard, Austria
Phone +43 5574 6735 0

