

F5

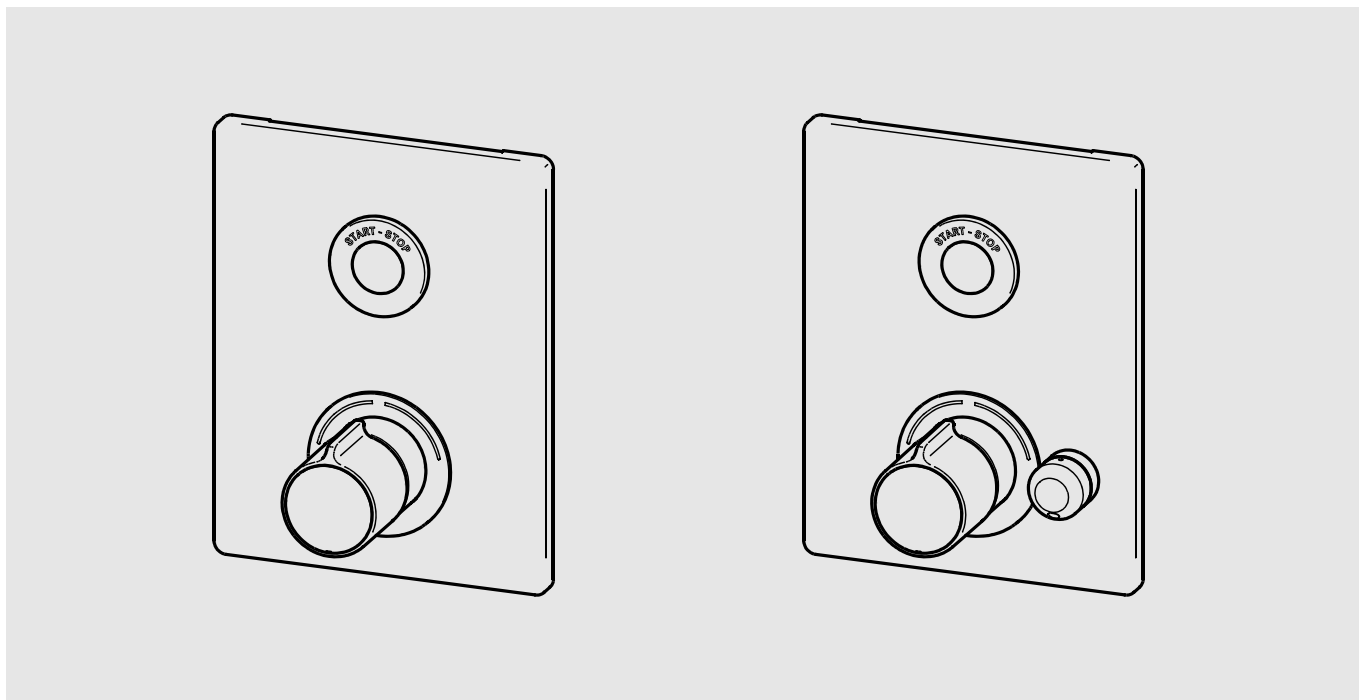

F5ET2031
2030067151

F5ET2033
2030067172

DE	Montage- und Betriebsanleitung	Elektronik-Thermostatbatterie
EN	Installation and operating instructions	Electronic thermostatic mixer
FR	Notice de montage et de mise en service	Mitigeur thermostatique électronique
ES	Instrucciones de montaje y servicio	Batería de termostato con sistema electrónico
IT	Istruzioni per il montaggio e l'uso	Miscelatore termostatico-elettronico
NL	Montage- en bedrijfsinstructies	Elektronische thermostaatmengkraan
PL	Instrukcja montażu i obsługi	Elektroniczna bateria termostat
SV	Monterings- och driftinstruktion	Elektronisk termostatenhet
CS	Návod pro montáž a provoz	Elektronická termostatická bate
FI	Asennus- ja käyttöohje	Elektroninen termostaattihana
RU	Инструкция по монтажу и вводу в эксплуатацию	



F5ET2031

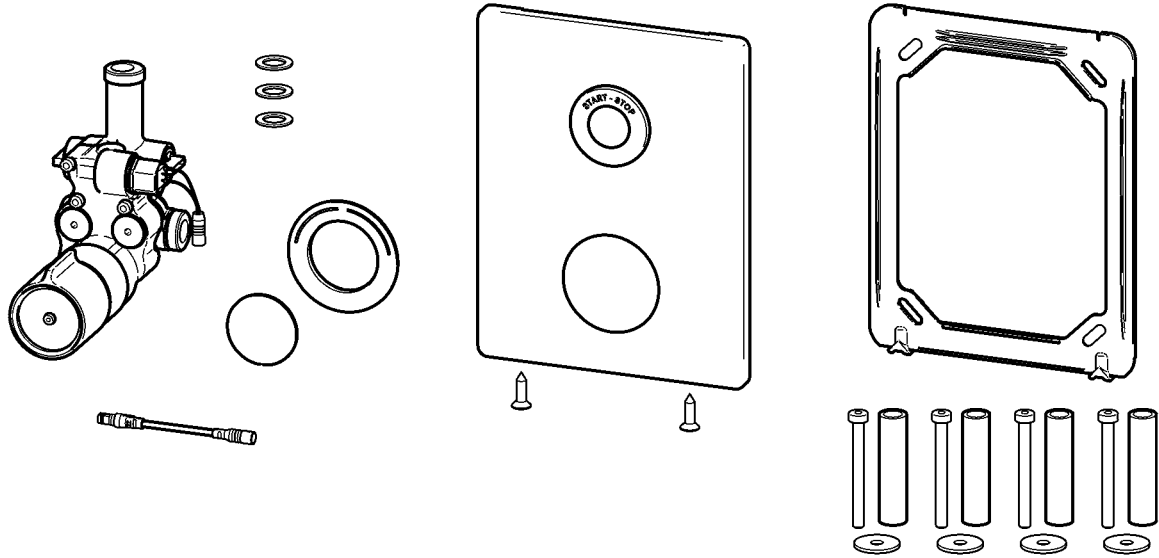

F5ET2033

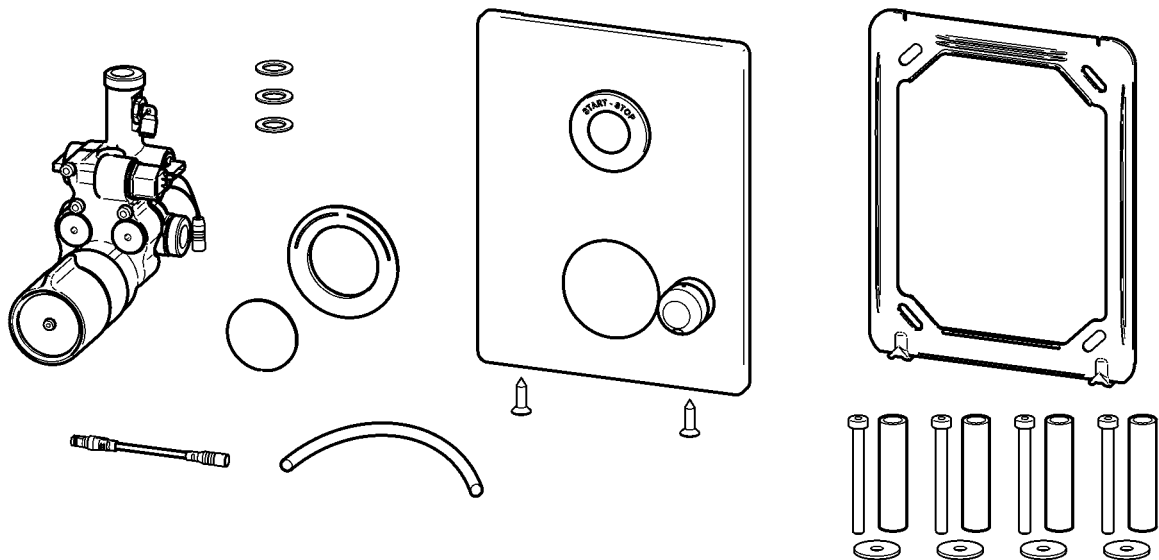



F5ET2031

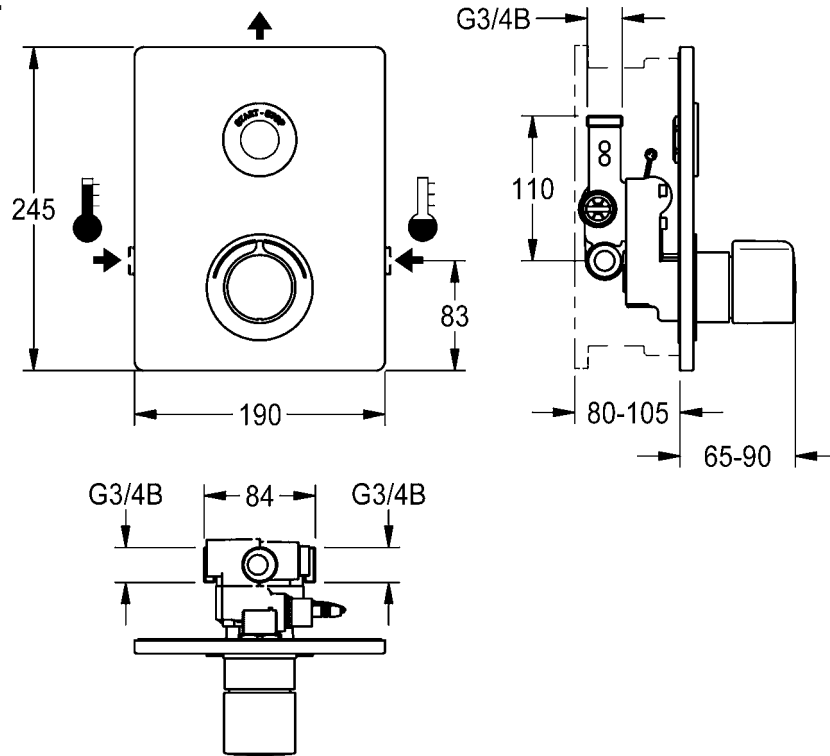

F5ET2033

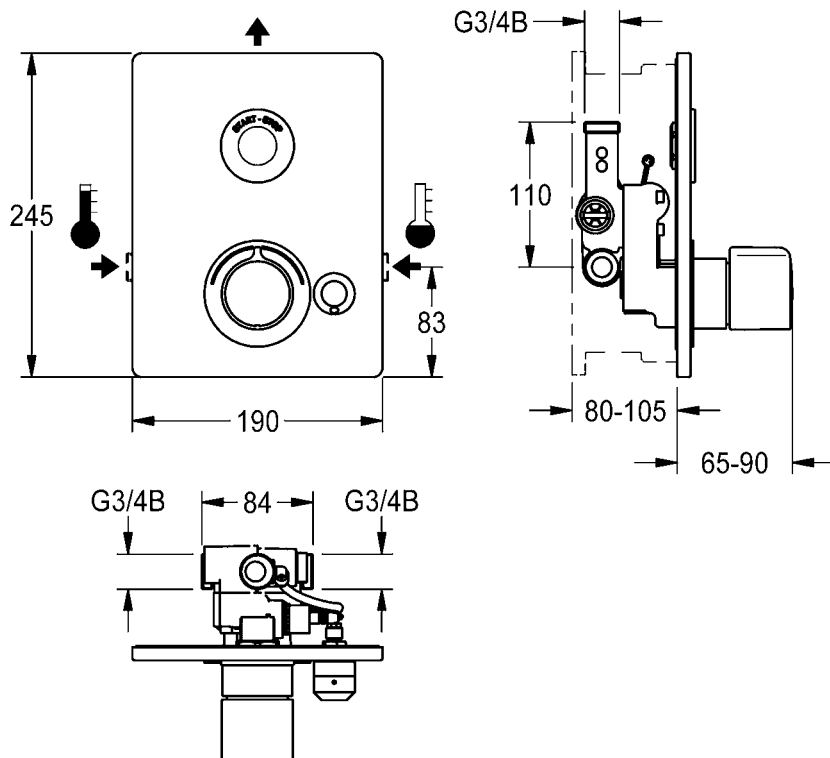

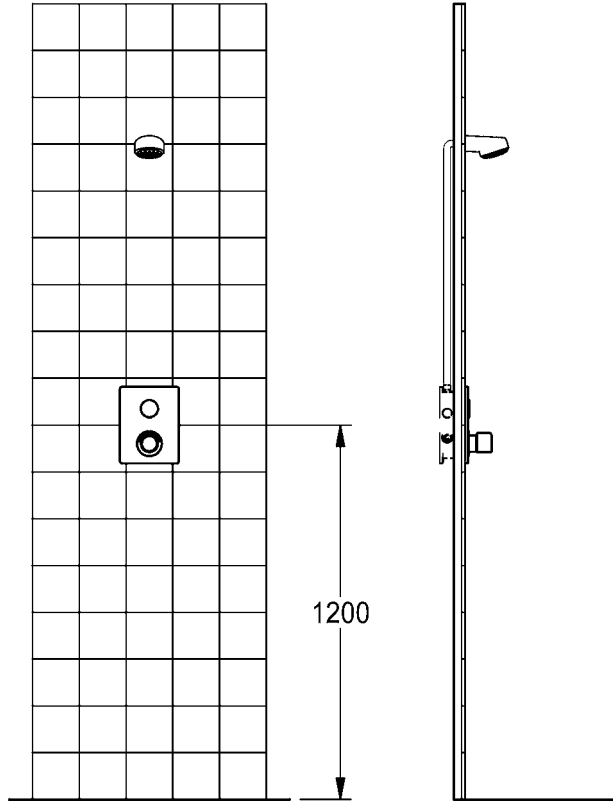

EN

Installation and operating instructions

Important notes

- ▶ All work must be carried out in a de-energised state.
- ▶ Before installing flush piping system!
- ▶ After completing the installation, set the temperature limiter!
- ▶ The fitting must be operated only with original mesh filters and return flow inhibitors!
- ▶ The fitting must be checked and maintained at regular intervals depending on the water quality and in accordance with the local conditions, and rules and regulations applicable at the site.
- ▶ The power supply must be ordered separately.

Technical data

- ▶ Minimum flow pressure 1.0 bar
- ▶ Maximum operating pressure 10 bar
- ▶ Recommended flow pressure 1-5 bar
- ▶ Volume flow at 3 bar flow pressure 13 l/min
- ▶ Thermostatic scald-protection in compliance with DIN EN 1111.
- ▶ maximum operating temperature
 - continuous operation 70 °C
 - short-term (<10 min) 80 °C
- ▶ Flow duration 30 s adjustable
- ▶ Supply voltage 6 – 24 V DC
- ▶ Power consumption 1,5 W
- ▶ Type of protection IP 59k (in assembled condition)

DE

Montage- und Betriebsanleitung

Wichtige Hinweise

- ▶ Alle Arbeiten im spannungsfreien Zustand durchführen.
- ▶ Vor Installation Rohrleitungen spülen!
- ▶ Nach erfolgter Montage die Temperaturbegrenzung einstellen!
- ▶ Armatur nur mit original Sieben und Rückflussverhinderern betreiben!
- ▶ In Abhängigkeit von der Wasserqualität, den örtlichen Gegebenheiten und den vor Ort geltenden Bestimmungen die Armatur in regelmäßigen Abständen prüfen und warten.
- ▶ Die Spannungsversorgung muss separat bestellt werden.

Technische Daten

- ▶ Mindestfließdruck 1,0 bar
- ▶ Maximaler Betriebsdruck 10 bar
- ▶ Empfohlener Fließdruck 1-5 bar
- ▶ Volumenstrom bei 3 bar Fließdruck 13 l/min
- ▶ Thermostatischer Verbrühungsschutz laut DIN EN 1111.
- ▶ maximale Betriebstemperatur
 - Dauerbetrieb 70 °C
 - Kurzzeit (<10 min) 80 °C
- ▶ Fließzeit 30 s einstellbar
- ▶ Anschlussspannung 6 – 24 V DC
- ▶ Leistungsaufnahme 1,5 W
- ▶ Schutzart IP 59k (im zusammengebauten Zustand)

Ważne wskazówki

- ▶ Wszystkie prace przeprowadzać po odłączeniu zasilania elektrycznego.
- ▶ Przed instalacją przepłukać rury!
- ▶ Po zakończeniu montażu ustawić ograniczenie temperatury!
- ▶ Armatury należy używać wyłącznie z oryginalnymi sitkami i zaworami zwrotnymi!
- ▶ Armaturę należy poddawać regularnej kontroli i konserwacji w zależności od jakości wody, warunków lokalnych i obowiązujących przepisów.
- ▶ Zasilanie elektryczne należy zamawiać oddzielnie.

Dane techniczne

- ▶ Minimalne ciśnienie przepływu 1,0 bar
- ▶ Maksymalne ciśnienie robocze 10 barów
- ▶ Zalecane ciśnienie przepływu 1-5 barów
- ▶ Objętościowe natężenie przepływu przy ciśnieniu 3 barów 13 l/min
- ▶ Termostatyczne zabezpieczenie przed poparzeniem zgodnie z DIN EN 1111.
- ▶ Maksymalna temperatura eksploatacji
 - Praca stała 70 °C
 - Czas krótki (<10 min) 80 °C
- ▶ Czas przepływu 30 s z możliwością ustawienia
- ▶ Napięcie przyłączeniowe 6 – 24 V DC
- ▶ Pobór mocy 1,5 W
- ▶ Rodzaj ochrony IP 59k (w zmontowanym stanie)

Viktiga informationer

- ▶ Genomför alla arbeten i spänningslöst tillstånd.
- ▶ Spola igenom rörledningarna före installation!
- ▶ När monteringen har gjorts skall temperaturbegränsningen ställas in!
- ▶ Använd armaturen endast med originalsilar och originalåterflödesförhindrare!
- ▶ Kontrollera och serva armaturen med intervaller som bestäms av vattenkvaliteten samt de lokala förhållandena och de bestämmelser som gäller där.
- ▶ Spänningsförsörjningen måste beställas separat.

Tekniska data

- ▶ Minsta hydrauliska tryck 1,0 bar
- ▶ Maximalt driftryck 10 bar
- ▶ Rekommenderat hydrauliskt tryck 1-5 bar
- ▶ Volymstrom vid 3 bar hydrauliskt tryck 13 l/min
- ▶ Termostatiskt skällningskydd enligt DIN EN 1111.
- ▶ Maximal driftstemperatur
 - Kontinuerlig drift 70 °C
 - Kort tid (< 10 min) 80 °C
- ▶ Flyttid 30 s inställbar
- ▶ Anslutningsspänning 6 – 24 V DC
- ▶ Effektbehov 1,5 W
- ▶ Skyddsklass IP 59k (i hopsatt tillstånd)

FR

Notice de montage et de mise en service

Remarques importantes

- ▶ Effectuez tous les travaux quand le dispositif est hors tension.
- ▶ Rincer les conduites avant d'installer !
- ▶ Une fois le montage terminé, régler la limitation de température !
- ▶ Ne faire fonctionner la robinetterie qu'avec les filtres et clapets de non retour d'origine !
- ▶ En fonction de la qualité de l'eau, ainsi que des conditions et des dispositions locales, il convient de contrôler et d'entretenir la robinetterie à intervalles réguliers.
- ▶ L'alimentation électrique doit être commandée séparément.

Données techniques

- ▶ Pression dynamique minimale 1,0 bar
- ▶ Pression de service maximale 10 bars
- ▶ Pression dynamique recommandée 1-5 bars
- ▶ Débit volumique pour 3 bars de pression dynamique 13 l/min
- ▶ Protection thermostatique contre les échaudures selon DIN EN 1111.
- ▶ Température de fonctionnement maximale
 - Fonctionnement continu 70 °C
 - Courte période (< 10 min) 80 °C
- ▶ Durée d'écoulement 30 s réglable
- ▶ Tension de raccordement 6 – 24 V DC
- ▶ Puissance absorbée 1,5 W
- ▶ Type de protection IP 59k (à l'état assemblé)

CS

Návod pro montáž a provoz

Důležité pokyny

- ▶ Veškeré práce vykonávejte ve stavu bez napětí.
- ▶ Před instalací potrubí propláchněte!
- ▶ Po provedené montáži nastavit omezení teploty!
- ▶ Provozovat armaturu jen s originálními sítky a zařízeními proti zpětnému toku!
- ▶ V závislosti na kvalitě vody, místních podmínkách a předpisech platných v místě instalace je nutné provádět v pravidelných intervalech kontrolu a údržbu armatury.
- ▶ Napájení je nutno objednat zvlášť.

Technické údaje

- ▶ Minimální průtočný tlak 1,0 bar
- ▶ Maximální provozní tlak 10 bar
- ▶ Doporučený průtočný tlak 1-5 bar
- ▶ Průtok $p_{\text{øi}}$ průtočném tlaku 3 bar 13 l/min
- ▶ Termostatická ochrana proti opažení podle normy DIN EN 1111.
- ▶ Maximální provozní teplota
 - Doba provozu 70 °C
 - Krátký čas (< 10 min.) 80 °C
- ▶ Doba průtoku nastavitelná 30 s
- ▶ Přípojné napětí 6 – 24 V DC
- ▶ Příkon 1,5 W
- ▶ Krytí IP 59k (ve smontovaném stavu)

ES

Instrucciones de montaje y servicio

Indicaciones importantes

- ▶ Todos los trabajos deben realizarse con la tensión de alimentación desconectada.
- ▶ ¡Enjuagar las tuberías antes de instalar!
- ▶ ¡Ajuste el límite de temperatura tras realizar el montaje!
- ▶ ¡La grifería debe hacerse funcionar únicamente con los tamices y las válvulas antiretorno originales!
- ▶ En función de la calidad del agua, las condiciones locales y la legislación vigente, realizar las inspecciones y el mantenimiento de la grifería a intervalos regulares.
- ▶ La fuente de alimentación debe pedirse por separado.

Datos técnicos

- ▶ Presión mínima de flujo 1,0 bar
- ▶ Presión máxima de servicio 10 bares
- ▶ Presión de flujo recomendada 1-5 bares
- ▶ Flujo volumétrico con 3 bares de presión de flujo 13 l/min
- ▶ Protección termostática frente a escaldaduras según DIN EN 1111.
- ▶ Temperatura de servicio máxima
 - Funcionamiento continuo 70 °C
 - Tiempo breve (< 10 min) 80 °C
- ▶ Tiempo de corriente 30 s ajustable
- ▶ Tensión de conexión 6 – 24 V DC
- ▶ Consumo de potencia 1,5 W
- ▶ Modo de protección IP 59k (en estado montado)

FI

Asennus- ja käyttöohje

Tärkeitä ohjeita

- ▶ Kaikki työt on tehtävä jännitteettömälle järjestelmälle.
- ▶ Huuhtelee putkijohdot ennen asennusta!
- ▶ Säädä asennuksen jälkeen lämpötilan rajoitus!
- ▶ Käytä varusteet vain alkuperäisten sihtien ja takaisinvirtauksen eston kanssa!
- ▶ Hana tulee tarkistaa ja huoltaa säännöllisin väliajoin veden laadusta, paikallisista oloista ja paikalla voimassa olevista määräyksistä riippuen.
- ▶ Jännitesyöttö on tilattava erikseen.

Tekniset tiedot

- ▶ Vähimmäisvirtauspaine 1,0 bar
- ▶ Suurin käyttöpaine 10 bar
- ▶ Suositeltava virtauspaine 1-5 bar
- ▶ Tilavuusvirta 3 barin virtauspaineella 13 l/min
- ▶ Termostaattinen kuumavesisuoja DIN EN 1111 mukaan
- ▶ Maksimaalinen käyttölämpötila
 - Jatkuva käyttö 70 °C
 - Lyhyt aika (<10 min) 80 °C
- ▶ Juoksuaika 30 s säädettävissä
- ▶ Verkkojännite 6 – 24 V DC
- ▶ Tehonkulutus 1,5 W
- ▶ Suojaustapa IP 59k (kootussa tilassa)

IT

Istruzioni per il montaggio e l'uso

Avvertenze importanti

- ▶ Eseguire tutti i lavori fuori tensione.
- ▶ Sciacquare le tubazioni prima di installare!
- ▶ Una volta terminata l'installazione, impostare la limitazione di temperatura!
- ▶ Utilizzare la rubinetteria esclusivamente con i filtri e le valvole antiriflusso originali!
- ▶ Controllare e sottoporre a manutenzione l'apparecchio ad intervalli regolari, in funzione della qualità dell'acqua, delle caratteristiche locali e delle vigenti disposizioni locali.
- ▶ L'alimentazione di tensione doccetta va ordinata a parte.

Specifiche tecniche

- ▶ Pressione idraulica min. 1,0 bar
- ▶ Pressione di esercizio max. 10 bar
- ▶ Pressione idraulica consigliata 1-5 bar
- ▶ Portata volumetrica a 3 bar di pressione idraulica 13 l/min
- ▶ Protezione antiscottatura termostatica secondo DIN EN 1111.
- ▶ Temperatura massima di esercizio
 - Funzionamento continuo 70 °C
 - Brevemente (<10 min) 80 °C
- ▶ Durata di flusso impostabile da 30 s
- ▶ Tensione di allacciamento 6 – 24 V DC
- ▶ Potenza assorbita 1,5 W
- ▶ Tipo di protezione IP 59k (Nello stato montato)

RU

Инструкция по монтажу и вводу в эксплуатацию

Важные указания

- ▶ Выполняйте все работы при отключенном напряжении.
- ▶ Перед инсталляцией промыть трубки!
- ▶ После монтажа отрегулировать температурный предел!
- ▶ Эксплуатировать арматуру только с оригинальными фильтрами и клапанами обратного течения!
- ▶ Арматуру необходимо регулярно чистить и обслуживать в зависимости от качества воды, местных условий и действующих в месте эксплуатации предписаний.
- ▶ Источник питания заказывается отдельно.

Технические характеристики

- ▶ Минимальный гидравлический напор 1,0 бар
- ▶ Максимальное рабочее давление 10 бар
- ▶ Рекомендуемый гидравлический напор 1-5 бар
- ▶ Объёмный расход при гидравлическом напоре 3 бар 13 л/мин
- ▶ Термостатическая система защиты от ожога горячим паром/жидкостью согласно стандарту DIN EN 1111.
- ▶ Максимальная рабочая температура
 - Непрерывный режим работы 70 °C
 - Короткое время (<10 мин) 80 °C
- ▶ Время протекания 30 сек. регулируемое
- ▶ Напряжение питающей сети 6 – 24 В постоянного тока
- ▶ Потребляемая мощность 1,5 Вт
- ▶ Вид защиты IP 59k (в собранном состоянии)

Belangrijke aanwijzingen

- ▶ Alle werkzaamheden in spanningsloze toestand uitvoeren.
- ▶ Voor installatie buisleidingen spoelen!
- ▶ Na de montage de temperatuurbegrenzing instellen!
- ▶ Armatuur alleen met originele zeven en terugstroomkleppen gebruiken!
- ▶ Afhankelijk van de waterkwaliteit, de plaatselijke omstandigheden en de plaatselijke voorschriften de armatuur regelmatig controleren en onderhouden.
- ▶ De stroomvoorziening moet apart worden besteld.

Technische gegevens

- ▶ Minimale dynamische druk 1,0 bar
- ▶ Maximale werkdruk 10 bar
- ▶ Aanbevolen dynamische druk 1-5 bar
- ▶ Volumestroom bij 3 bar dynamische druk 13 l/min
- ▶ Thermostatische beveiliging tegen verbranding volgens DIN EN 1111.
- ▶ Maximale bedrijfstemperatuur
 - Continubedrijf 70 °C
 - Kortstondig (<10 min) 80 °C
- ▶ Stromingstijd 30 s instelbaar
- ▶ Aansluitspanning 6 – 24 V DC
- ▶ Opgenomen vermogen 1,5 W
- ▶ Veiligheidsgraad IP 59k (in gemonteerde toestand)



1. Montage

EN Installation
FR Montage
ES Montaje
IT Montaggio

NL Montage
PL Montaż
SV Montering

CS Montáž
FI Asennus
RU Монтаж



19 mm
27 mm
30 mm

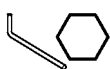

2,5 mm
3 mm
5 mm



3 mm

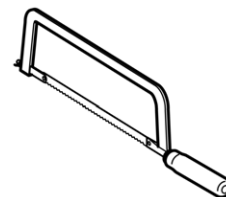
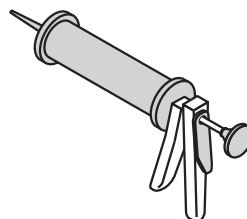
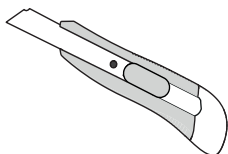
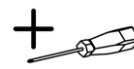

1

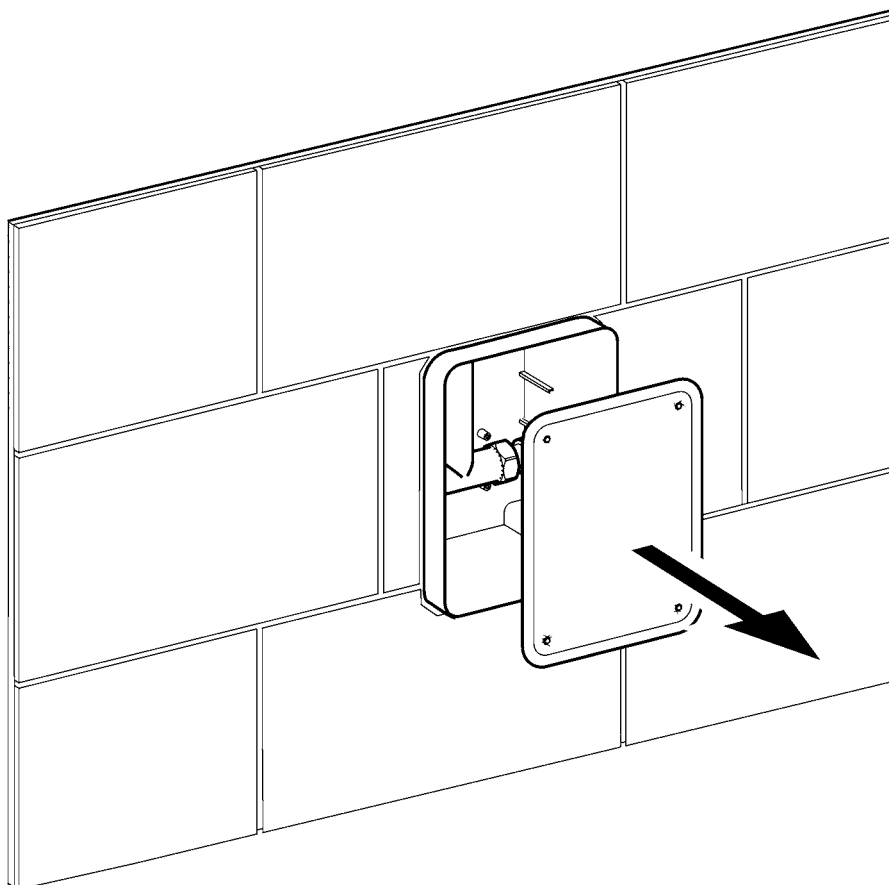

2

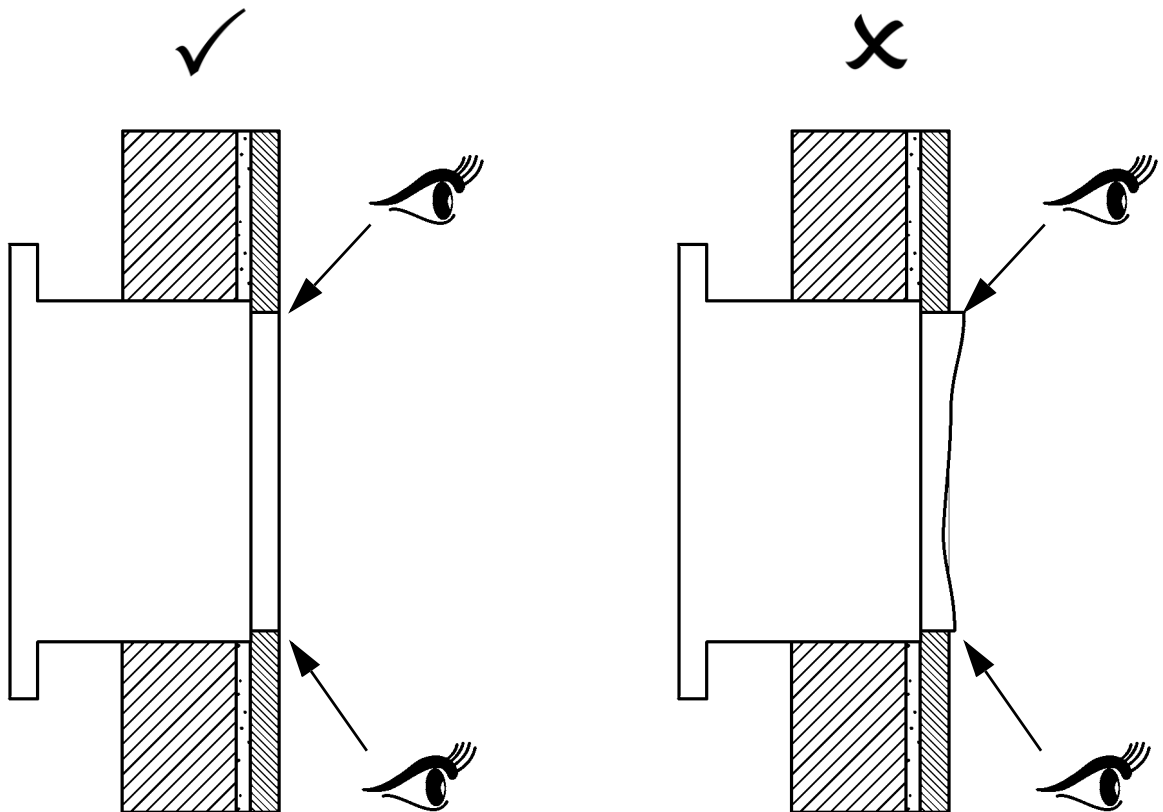
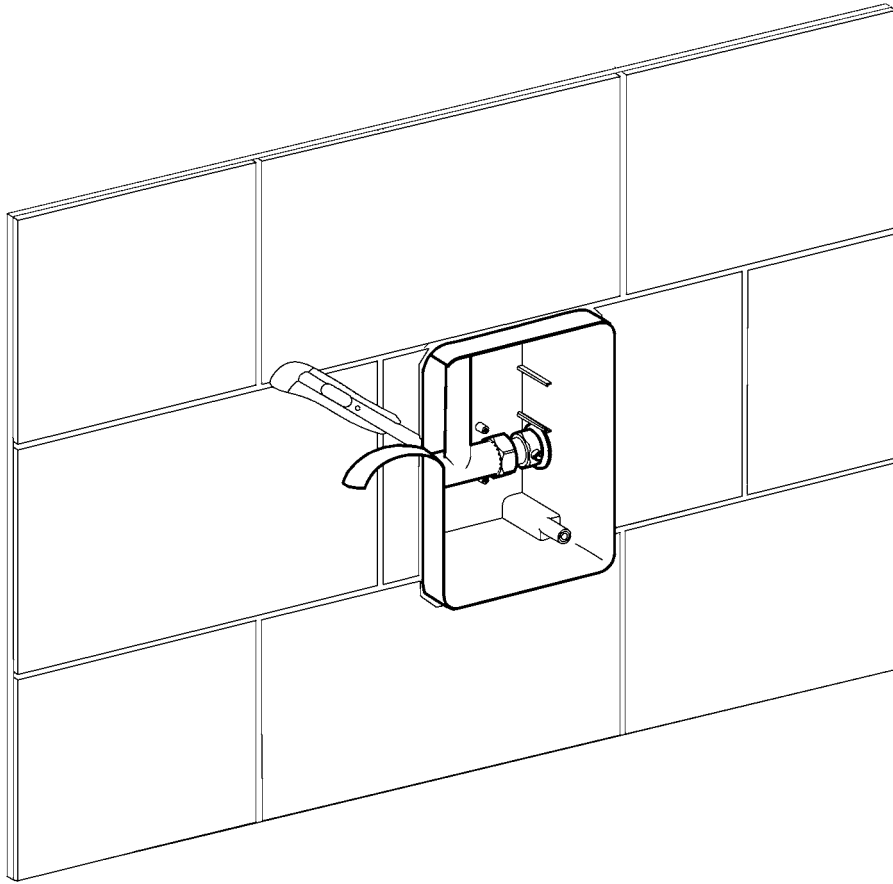

3

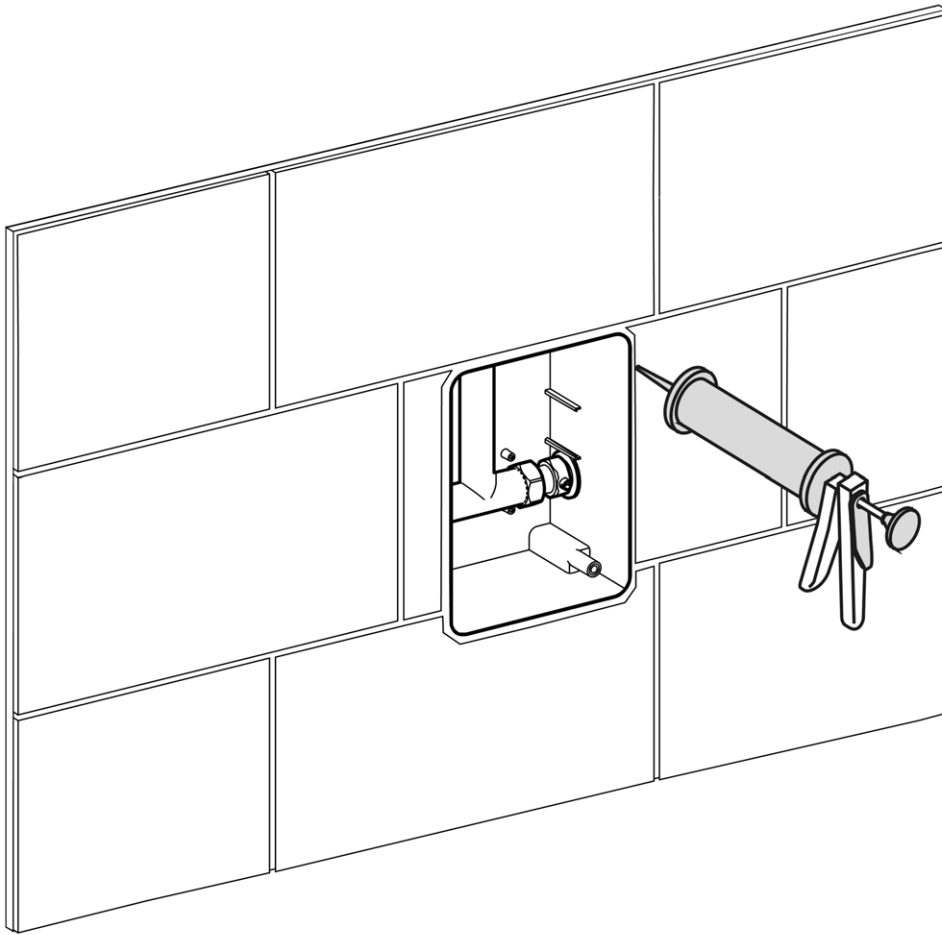

4

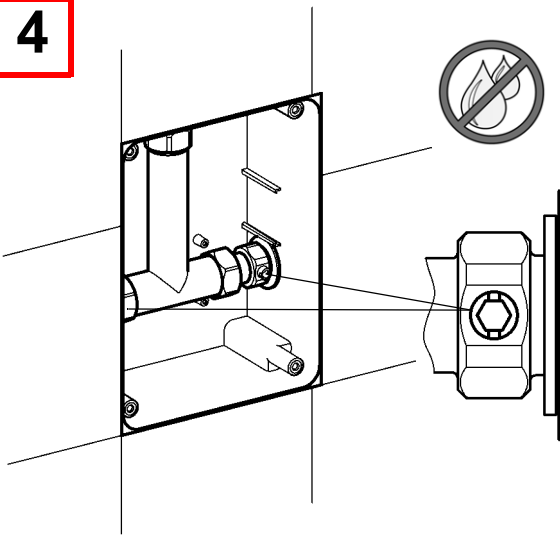

5

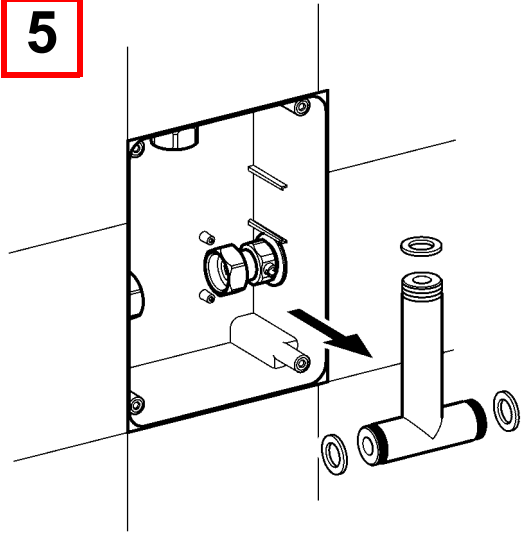

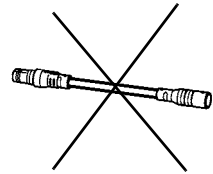
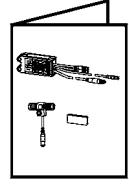
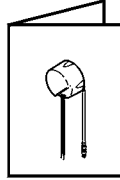
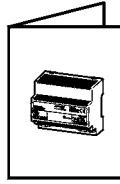
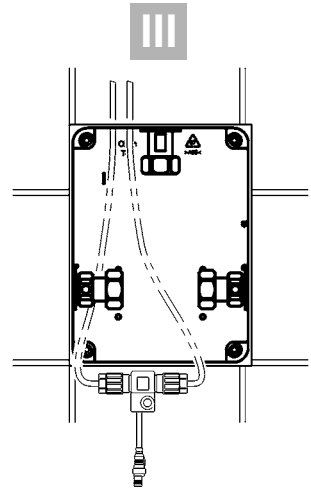
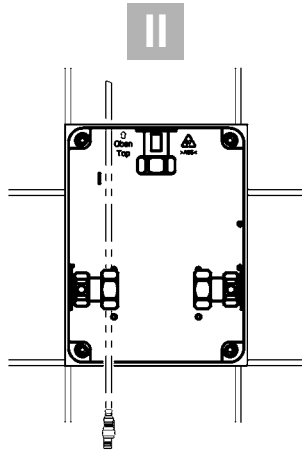
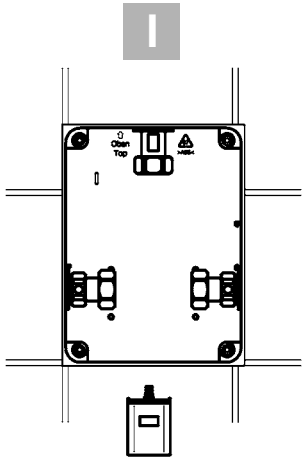

6

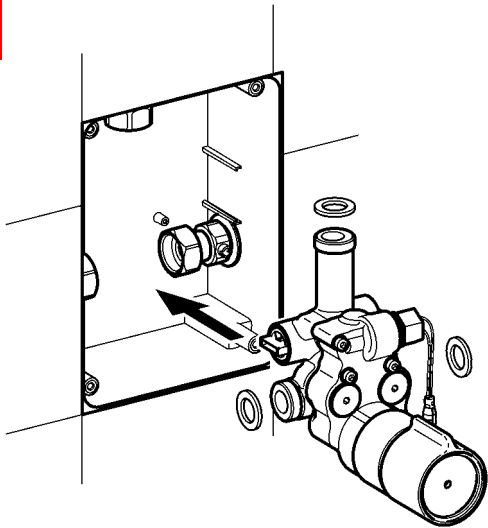

7

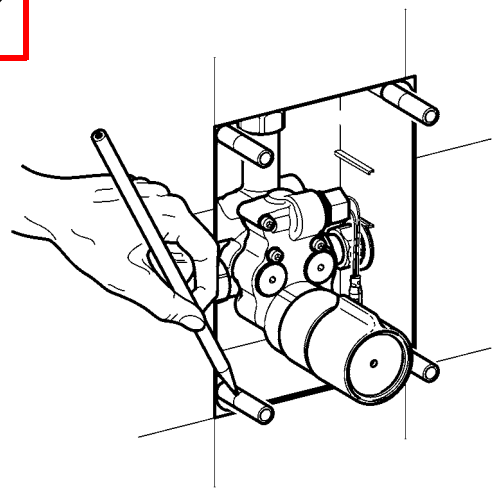

8

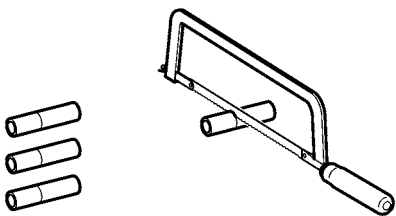

9

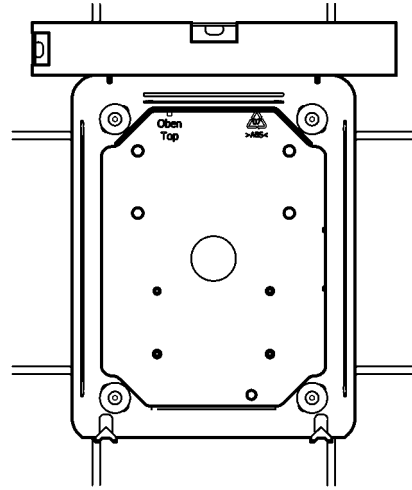
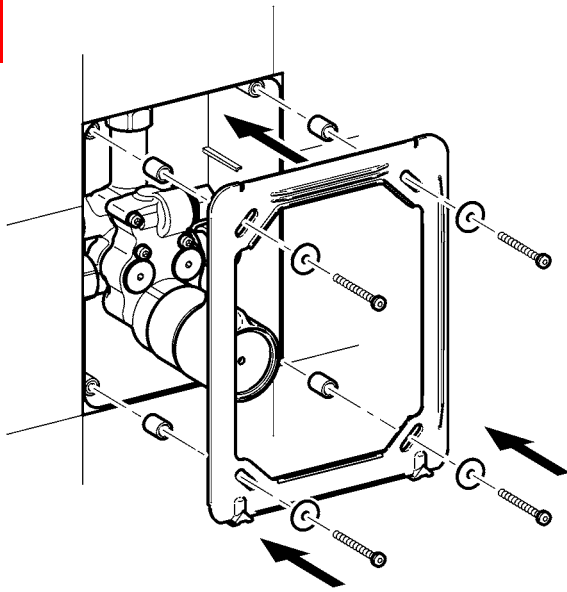

10

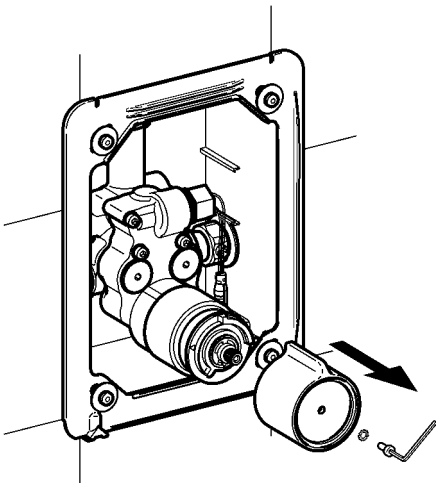

11

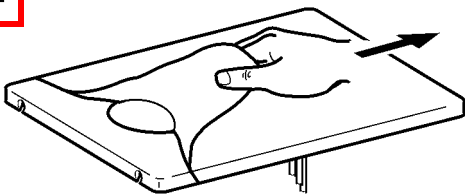

12

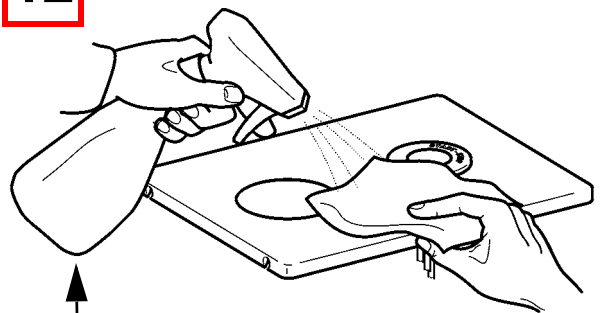

23.

F5ET2033

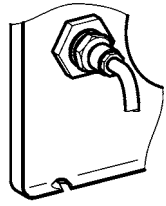

13 - 17

13

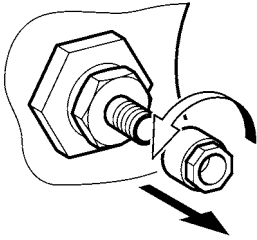

14

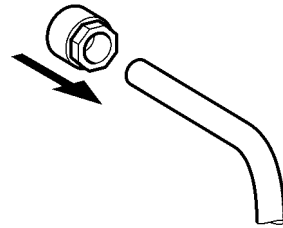

15

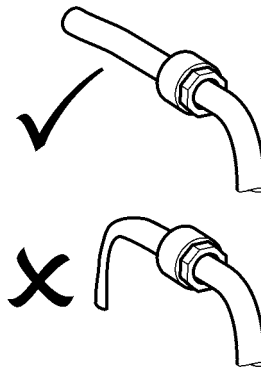
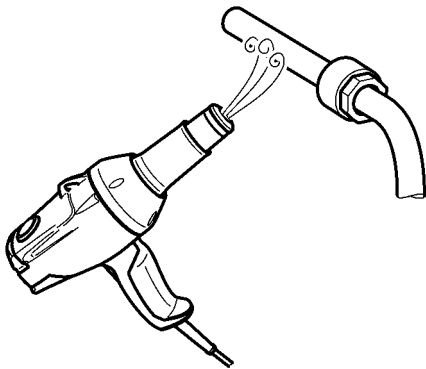

16

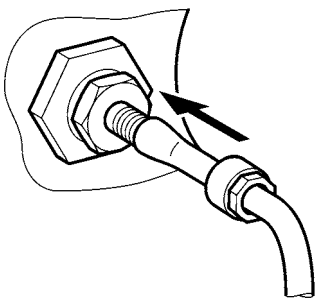

17

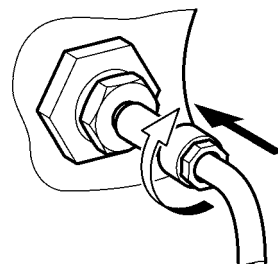

18

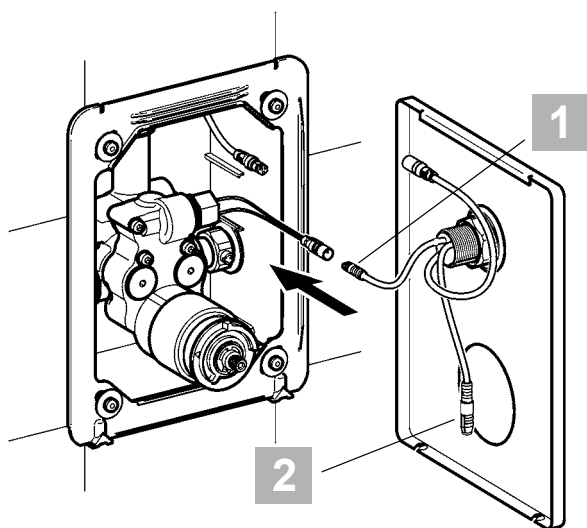

EN 1: Black
2: Red

PL 1: Czarny
2: Czerwony

DE 1: Schwarz
2: Rot

SV 1: Svart
2: Röd

FR 1: Noir
2: Rouge

CS 1: černá
2: Červený

ES 1: Negro
2: Rojo

FI 1: Musta
2: Punainen

IT 1: Nero
2: Rosso

RU 1: черный
2: красный

NL 1: Zwart
2: Rood

19

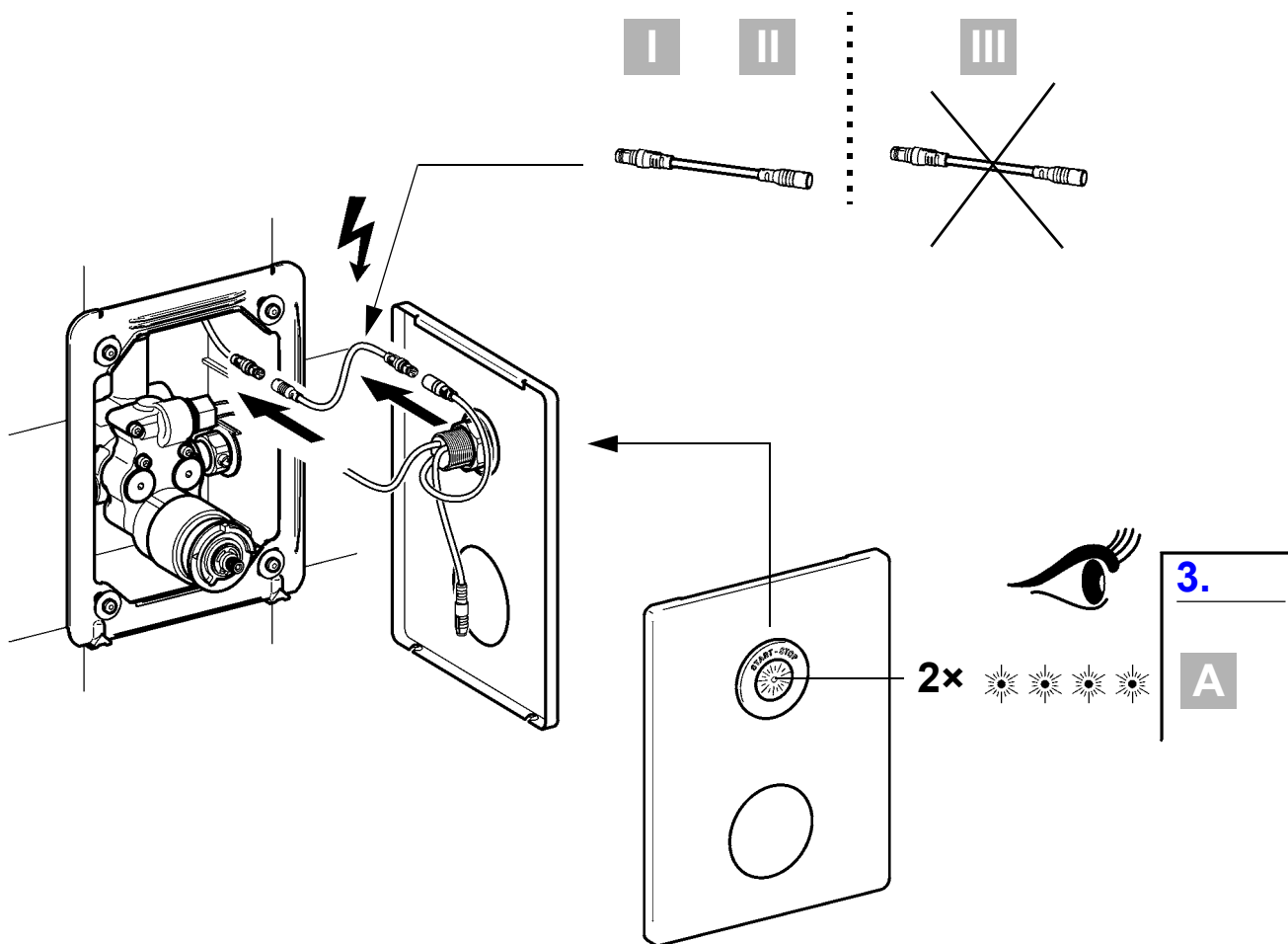

20

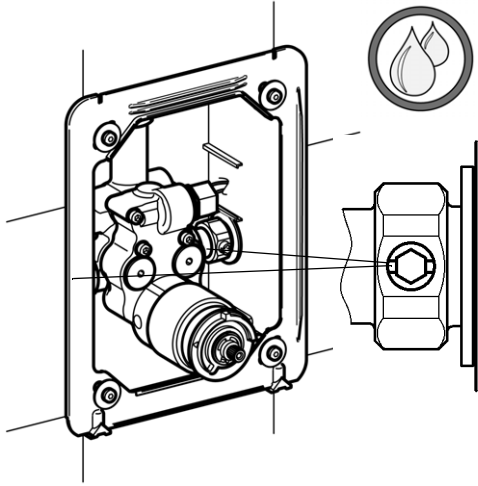

F5ET2033

21

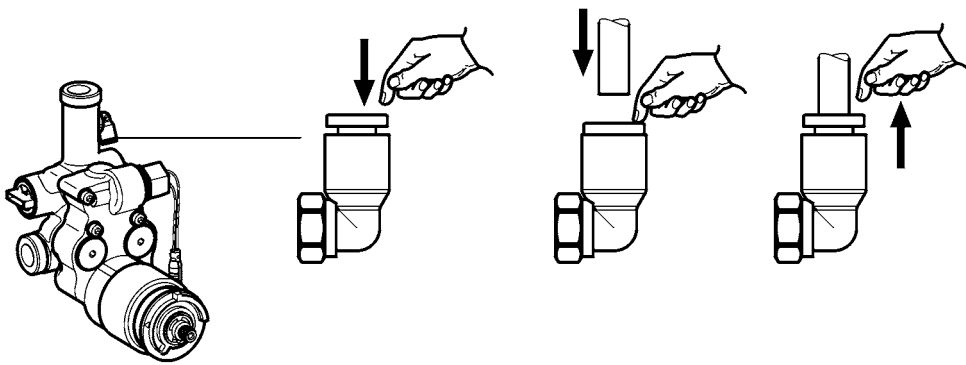

22

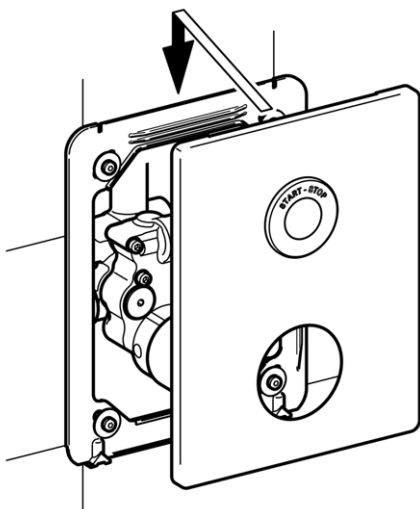

23

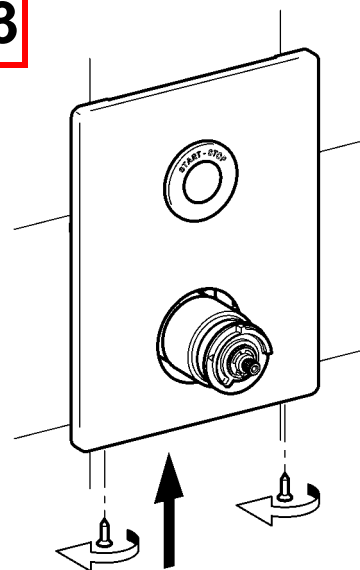

24

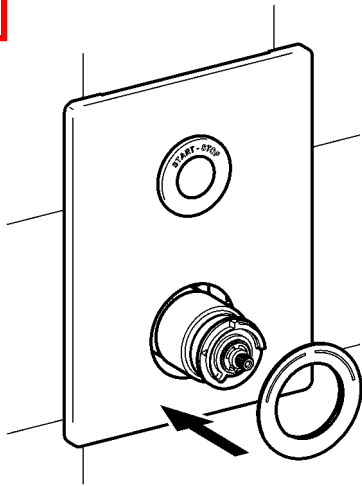

25

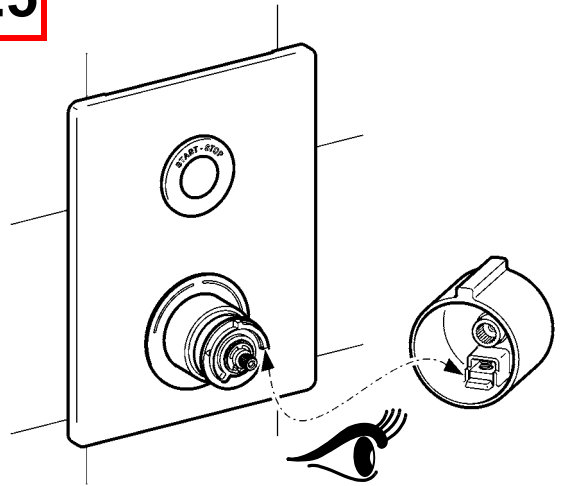

26

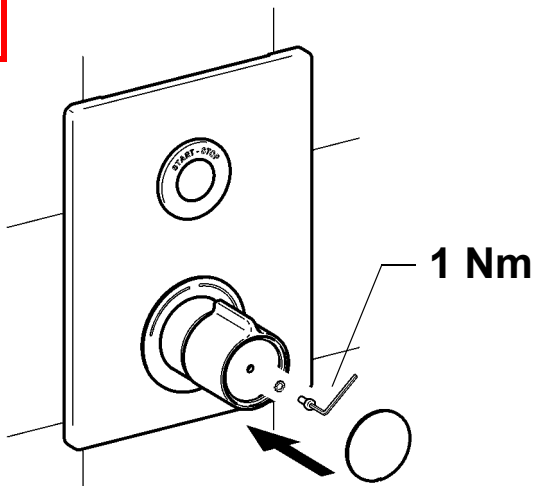

2. Funktion

EN Function
FR Fonctionnement
ES Función
IT Funzionamento

NL Werking
PL Funkcja
SV Funktion

CS Funkce
FI Toiminto
RU Функционирование

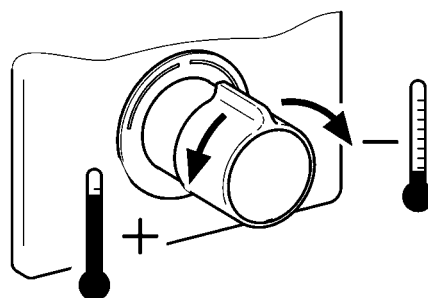
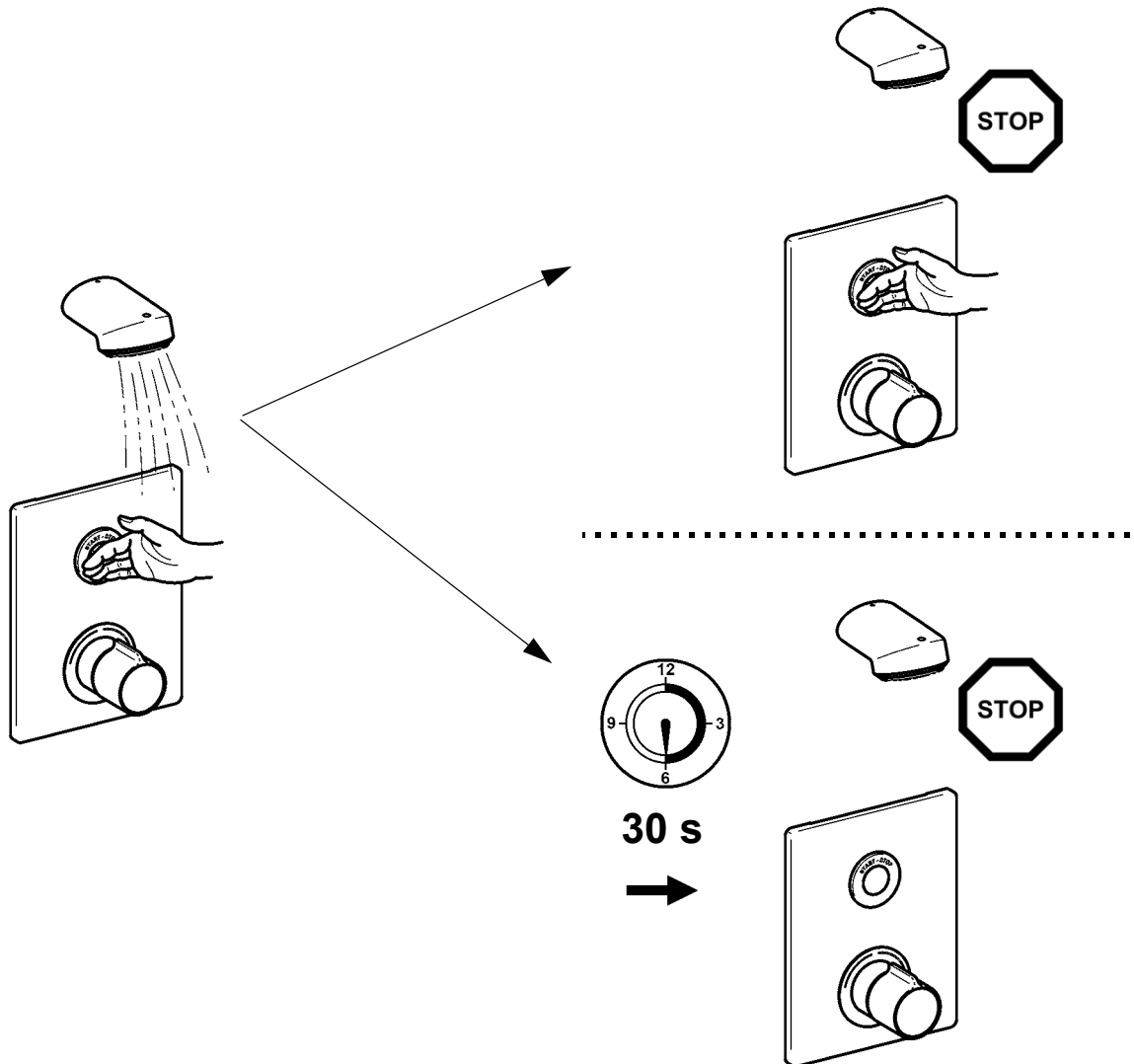

3. Hygienspülung ein- / ausschalten

EN Switching hygiene flushing on/off	NL Hygiënische spoeling in-/uitschakelen	CS Zapněte/vypněte hygienické propláchnutí
FR Activer/désactiver le rinçage hygiénique	PL Włączyć/wyłączyć spłukiwanie higieniczne	FI HygieniahuuhTELun päälle-/ pois päältä kytkeminen
ES Activar/Desactivar el aclarado higiénico	SV Koppla hygienspolningen till / från	RU Гигиеническое промывание включить/выключить
IT Attivare/disattivare lo sciacquo igienico		

- EN**
- ▶ Ensure open outlet.
 - ▶ After 24h of non-use, water flows 30 s
- DE**
- ▶ Freien Auslauf gewährleisten.
 - ▶ Nach 24 h Nichtbenutzung fließt 30 s Wasser.
- FR**
- ▶ Garantir un écoulement libre.
 - ▶ L'eau s'écoule pendant 30 s. après 24 h de non utilisation.
- ES**
- ▶ Garantizar una salida libre.
 - ▶ Si no se realiza ningún uso durante 24 horas, fluye agua durante 30 segundos.
- IT**
- ▶ Garantire l'erogazione libera.
 - ▶ Dopo 24h di inutilizzo scorre acqua per 30 s.
- NL**
- ▶ Vrije uitloop garanderen.
 - ▶ Na 24 uur niet te zijn gebruikt stroomt er gedurende 30 s. water.
- PL**
- ▶ Zapewnić swobodny wylot.
 - ▶ Po 24 godz. niekorzystania przez 30 s. wypływa woda.
- SV**
- ▶ Garantera fritt avlopp.
 - ▶ Vatten flyter 30 s efter 24 timmars användningspaus.
- CS**
- ▶ Zajistěte volný odtok.
 - ▶ Při nepoužívání 24 h nechte 30 s téct vodu.
- FI**
- ▶ Vapaan virtauksen takaaminen.
 - ▶ Käyttämättömänä 24 h jälkeen virtaa vettä 30 s.
- RU**
- ▶ Обеспечить беспрепятственный слив
 - ▶ После того, как устройство не используется в течение 24 ч, в течение 30 сек течёт вода.

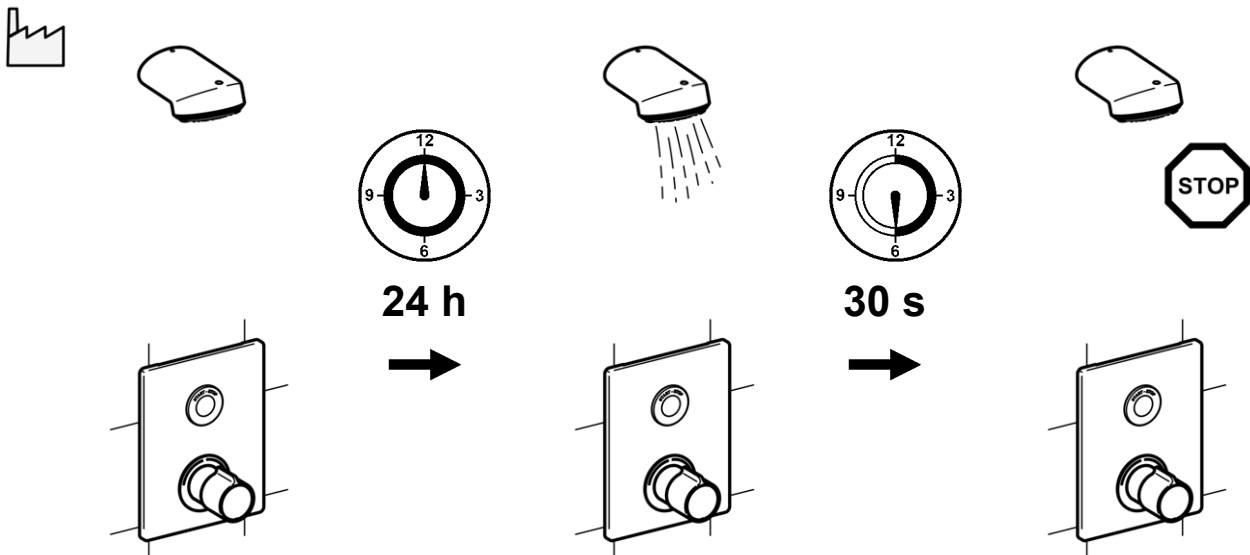

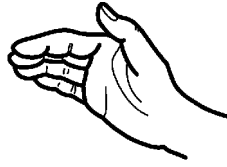
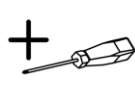
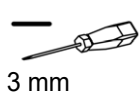
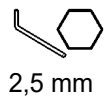

1 - 13

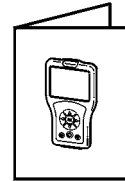
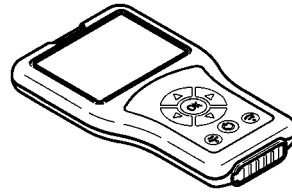
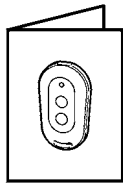
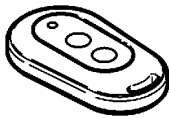

1

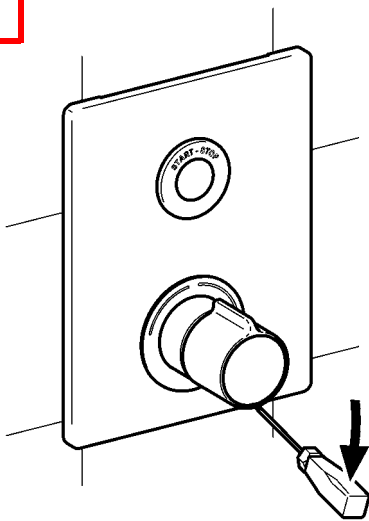

2

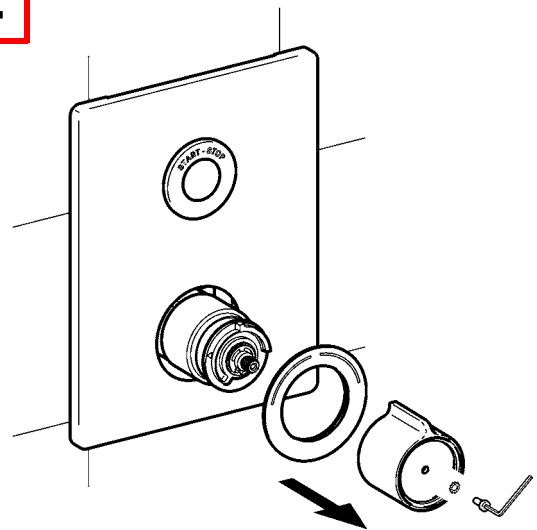

3

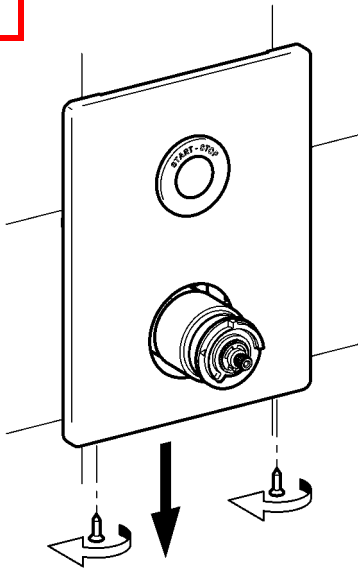

4

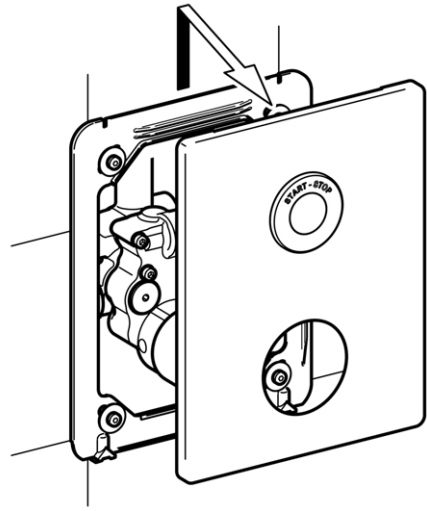



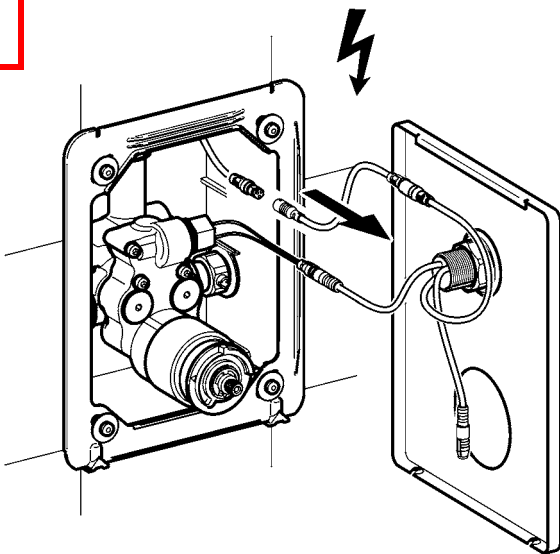



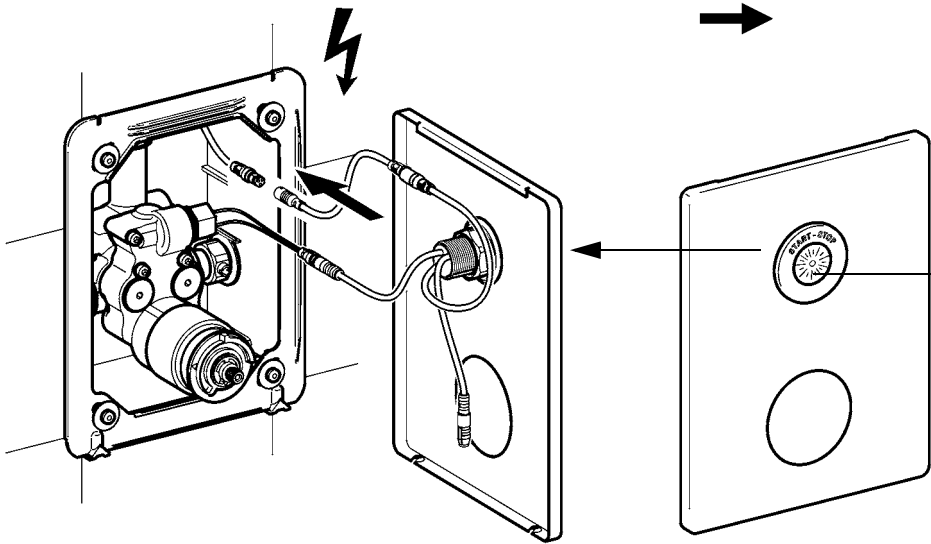
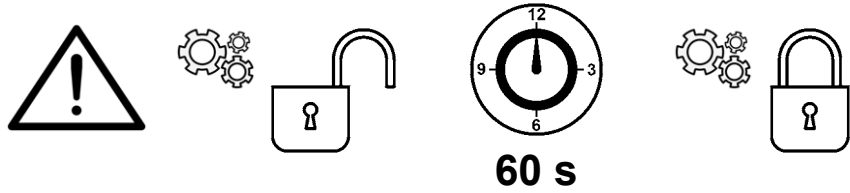

5



6



- A** 2x    
- B** 1x    

A

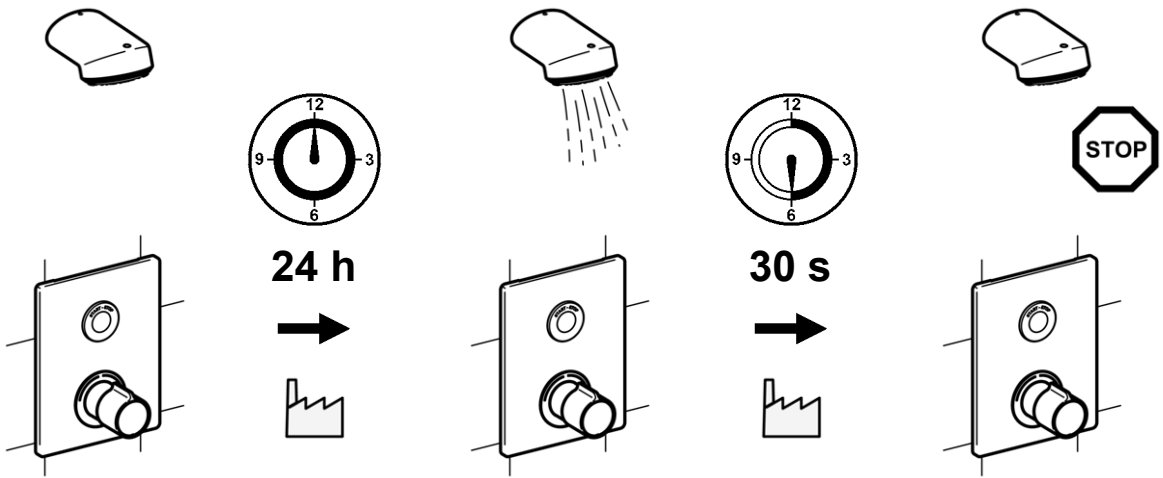

B

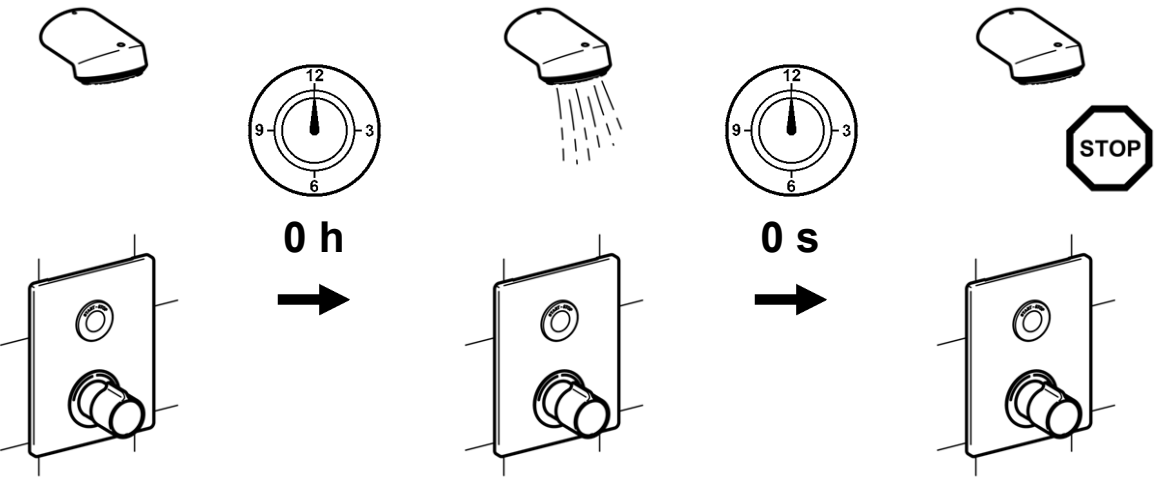

7

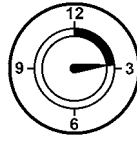
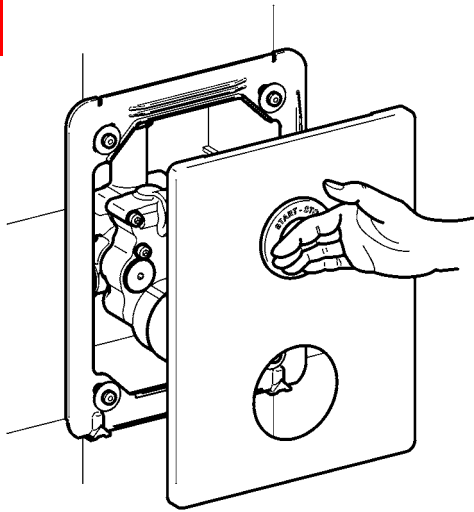

>12 s

8

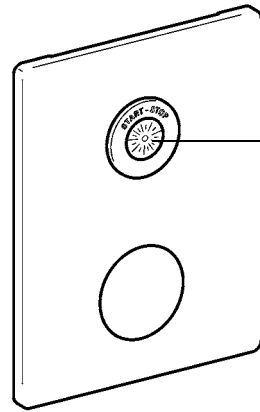
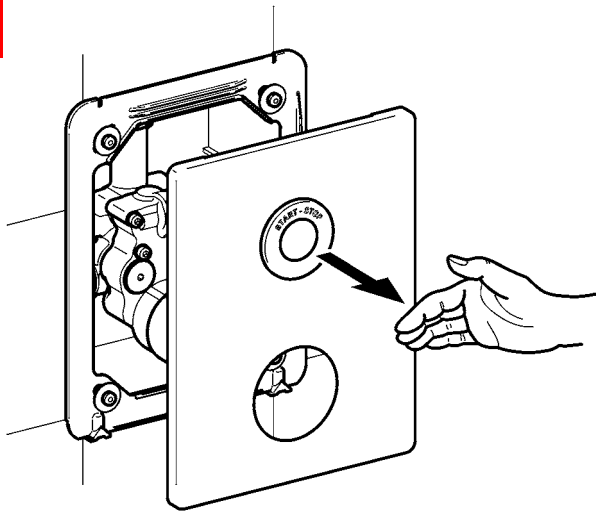

1x

9

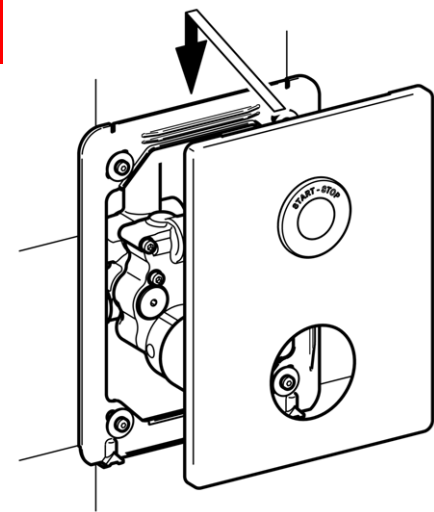

10

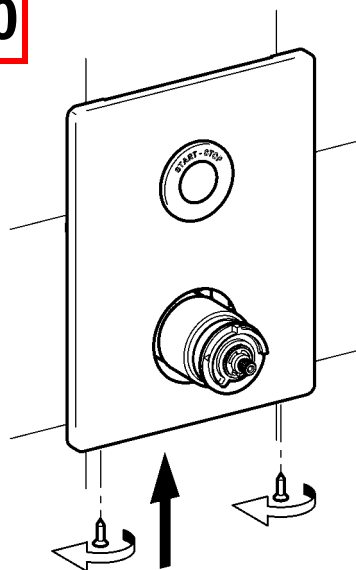

11

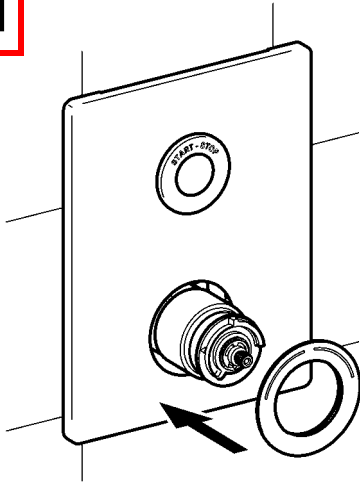

12

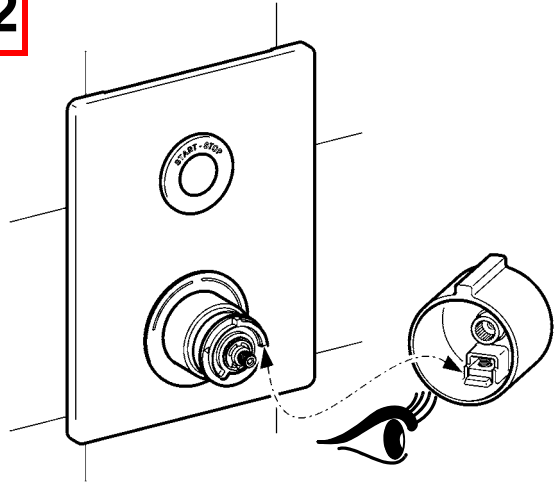

13

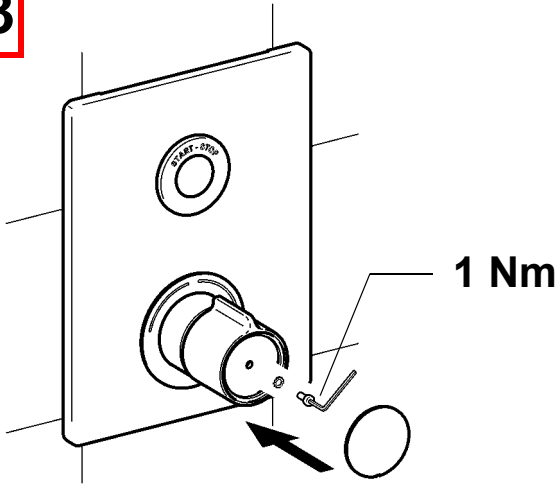

4. Thermische Desinfektion

EN Thermal disinfection
FR Désinfection thermique
ES Desinfección térmica
IT Disinfezione termica

NL Thermische desinfectie
PL Dezynfekcja termiczna
SV Termisk desinfektion

CS Tepelná dezinfekce
FI Terminen desinfiointi
RU Термическая дезинфекция

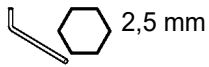

1

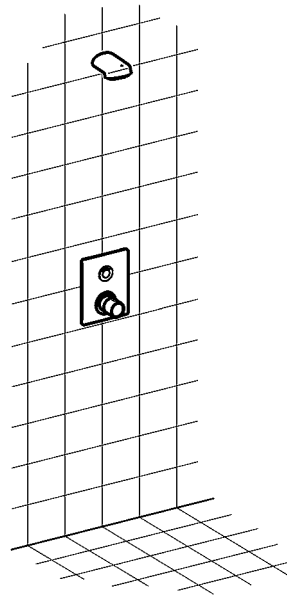
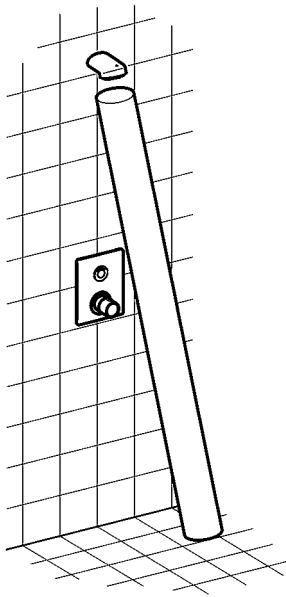

2

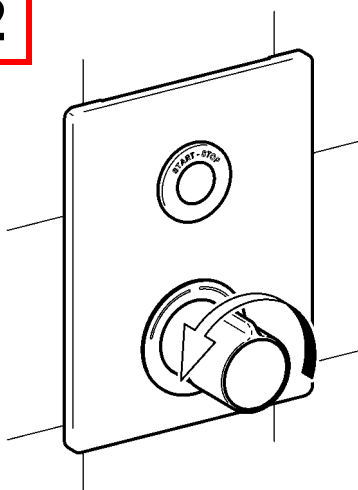

3

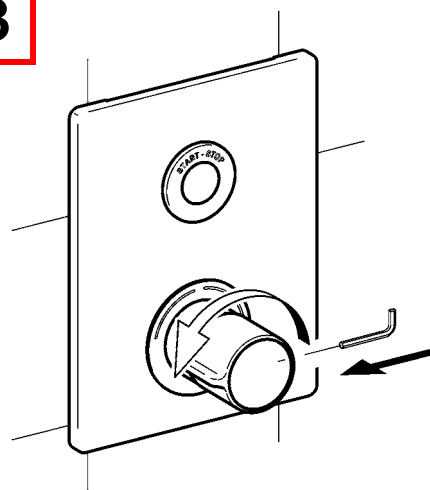

4

> 70 °C

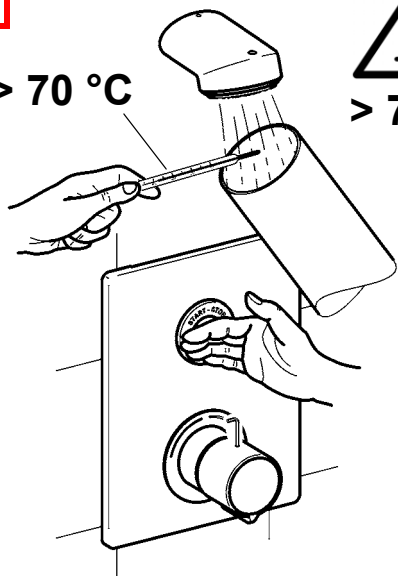

5

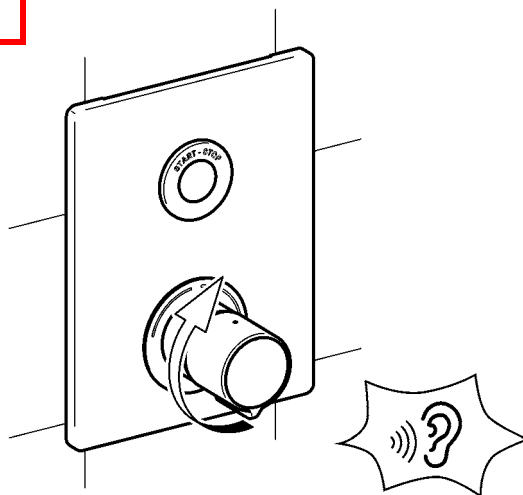

6

< 43 °C

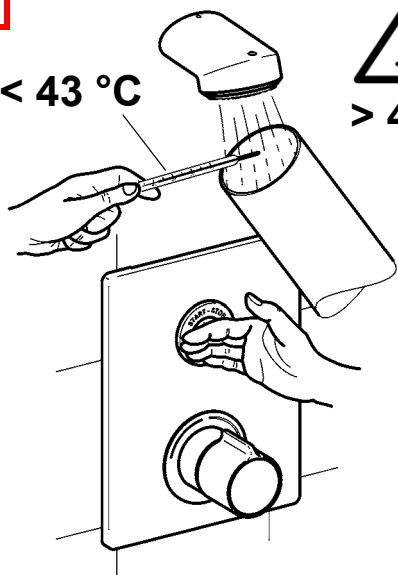

5. Reinigungsabschaltung einschalten

EN Switch on cleaning switch-off	NL Inschakelen van de reiniging shutdown	CS Vypínač pro čištění
FR Activer l'arrêt de nettoyage	PL Włączanie wyłączenia na czas czyszczenia	FI Aktivoida pesuseisokkien
ES Activar el apagado de limpieza	SV Aktivera rengörings avstängning	RU активировать чистка завершение работы
IT Attivare dello spegnimento per pulizia		

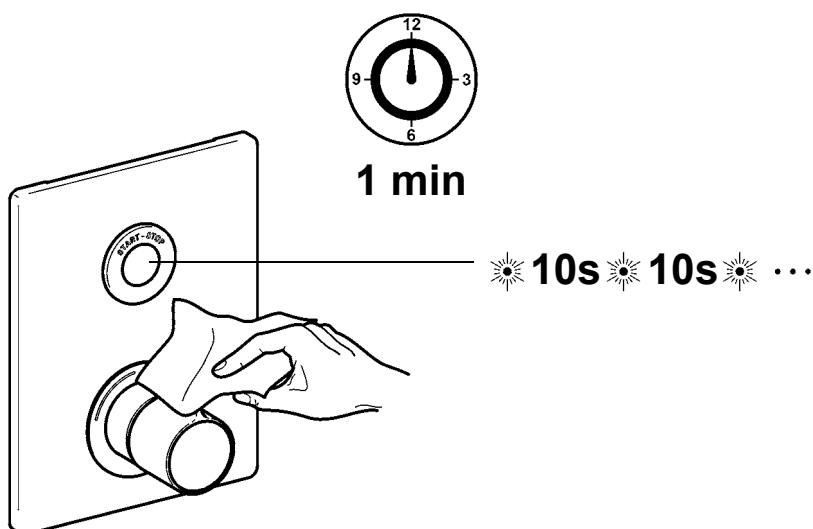
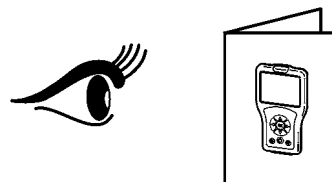
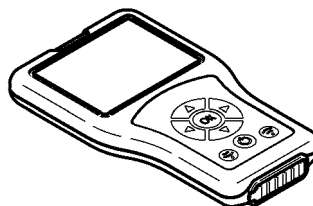
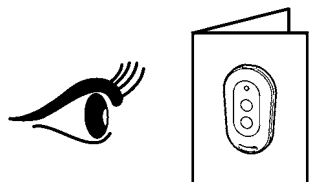

6. Fließzeit einstellen

EN Adjust flow duration

NL Stroomingstijd instellen

CS Nastavit dobu průtoku

FR Régler la durée d'écoulement

PL Ustawić czas przepływu

FI Aseta virtausaika

ES Ajustar el tiempo de flujo

SV Ställa in flytförmågan

RU Регулировка времени истечения

IT Impostazione della durata di flusso

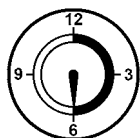
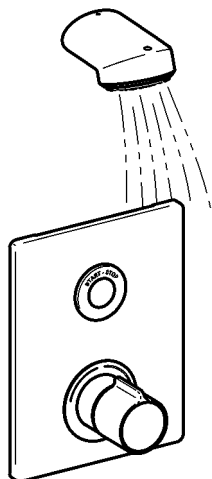

30 s

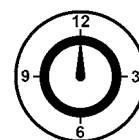
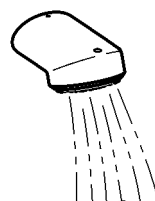
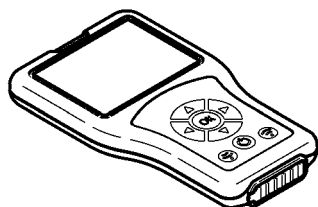

1 – 255 s

7. Hygienespülung einstellen

EN Setting the hygiene flush	NL Instellen van de hygiënespoeling	CS Nastavení hygienického proplachování
FR Réglage de la rinçage d'hygiène	PL Ustawianie spłukiwania higienicznego	FI Hygieniahuuhtelun säätäminen
ES Ajuste del higiene enjuague	SV Ställa in hygienspolning	RU установив гигиена смыва
IT Impostare lo igiene risciacquo		

- EN**
- ▶ C: Interval adjustable in h
 - ▶ D: Flow duration adjustable in s
- DE**
- ▶ C: Intervall einstellbar in h
 - ▶ D: Fließzeit einstellbar in s
- FR**
- ▶ C: intervalle réglable en h
 - ▶ D: durée d'écoulement réglable en s
- ES**
- ▶ C: Intervalo ajustable en horas
 - ▶ D: Tiempo de flujo activable en seg
- IT**
- ▶ C: intervallo impostabile in h
 - ▶ D: durata di flusso impostabile in s
- NL**
- ▶ C: Interval instelbaar in u
 - ▶ D: Stromingstijd instelbaar in s
- PL**
- ▶ C: odstęp czasu regulowany w godzinach
 - ▶ D: czas przepływu regulowany w sekundach
- SV**
- ▶ C: Intervall kan ställas in i timmar
 - ▶ D: Flödestid kan ställas in i sekunder
- CS**
- ▶ C: Interval s nastavením v h
 - ▶ D: Doba průtoku s nastavením v s
- FI**
- ▶ C: Aikaväli, asetettavissa h
 - ▶ D: Virtausaika, asetettavissa s
- RU**
- ▶ C: интервал задается в ч
 - ▶ D: время течения задается в сек

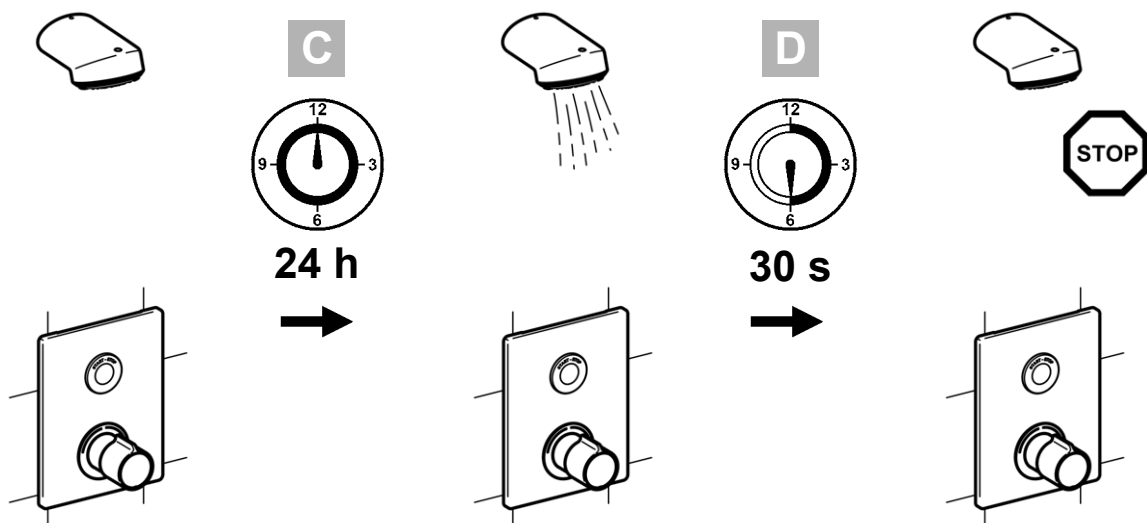

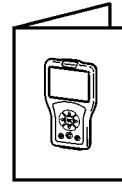
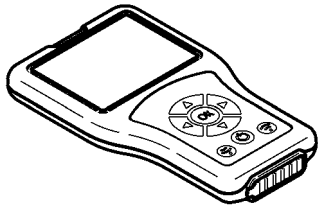

C

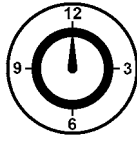

1 - 255 h

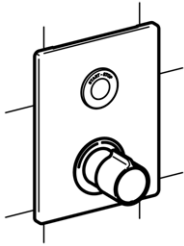

D

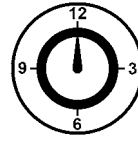

1 - 255 s

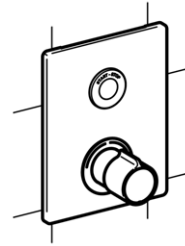
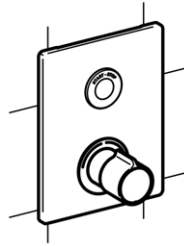

8. Reinigungsabschaltung einstellen

EN Set the range
FR Régler le rayon d'action
ES Regular el alcance
IT Impostare la portata

NL Actieradius instellen
PL Ustawienie zasięgu
SV Ställa in räckvidden

CS Nastavení dosahu
FI Aseta ulottuma
RU установить диапазон значений

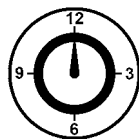
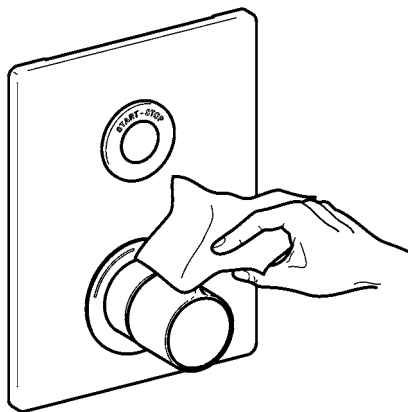

1 min

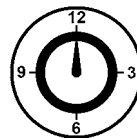
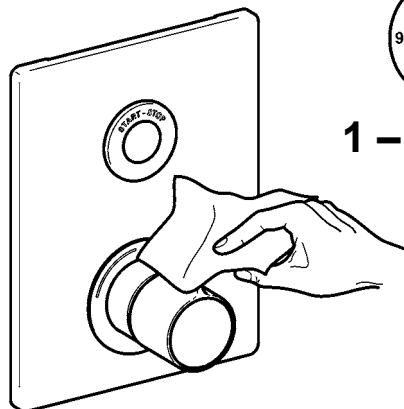
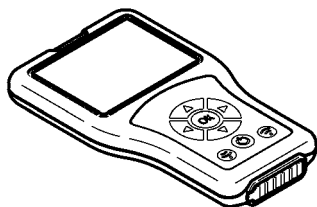

1 – 255 min

9. Verbrühungsschutz einstellen

EN Adjust scald protection	NL Bescherming tegen verbranding instellen	CS Nastavte ochranu proti opaření
FR Réglage du dispositif de protection contre les échaudures	PL Ustawianie zabezpieczenia przed poparzeniem	FI Palovammasuojan asettaminen
ES Ajustar la protección contra escaldaduras	SV Inställning av skållningsskydd	RU Настройка защиты от ошпаривания
IT Impostare la protezione antiscottatura		



EN

Warning

If the hot-water supply temperature is greater than 43 °C, set the scald-protector.

Failure to observe can cause bodily harm due to scalding.

DE

Warnung

Wenn die Temperatur der Warmwasserversorgung mehr als 43 °C beträgt, den Verbrühungsschutz einstellen.

Nichtbeachtung kann Körperverletzung durch Verbrühung bewirken.

FR

Avertissement

Si la température de l'alimentation eau chaude dépasse 43 °C, il convient de régler le dispositif de protection contre les échaudures.

Le non-respect est susceptible de provoquer des blessures corporelles par échaudure.

ES

Aviso

Si la temperatura del suministro de agua caliente es superior a 43 °C, de ajusta la protección contra escaldaduras.

La no observación puede tener como consecuencia escaldaduras.

IT

Avvertenza

Se la temperatura dell'alimentazione acqua calda è superiore a 43 °C, impostare la protezione antiscottatura.

La non osservanza può causare ustioni.

NL

Waarschuwing

Indien de temperatuur van de watervoorziening hoger is dan 43 °C, de bescherming tegen verbranding instellen. Veronachtzaming kan letsel door verbranden veroorzaken.

PL

Ostrzeżenie

Jeśli temperatura wody w instalacji doprowadzającej przekracza 43 °C, należy ustawić zabezpieczenie przed poparzeniem.

Nieprzestrzeganie tego zalecenia może prowadzić do urazów ciała spowodowanych poparzeniem.

SV

Varning

Skållningsskyddet ska ställas in om varmvattnet blir varmare än 43 °C. Inställning av skållningsskydd.

Om detta inte efterföljs finns det risk för skållningsskador.

CS

Varování

Když teplota přiváděné teplé vody činí více než 43 °C, nastavte ochranu proti opaření.

Nerespektování může vést k poranění opařením.

FI

Varoitus

Kun lämminvesisyötön lämpötila on enemmän kuin 43 °C, aseta palovammasuoja.

Huomioon ottamatta jättäminen voi saada aikaan vartalovamman palovammasta.

RU

Предупреждение

Если температура в линии подачи горячей воды больше 43 °C, настройте защиту от ошпаривания.

Вследствие несоблюдения данного указания возможно нанесение вреда здоровью в результате ошпаривания.

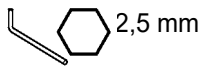

1

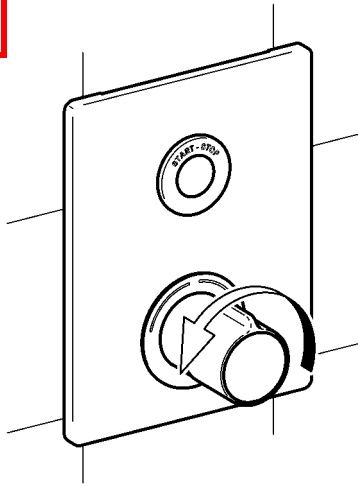

2

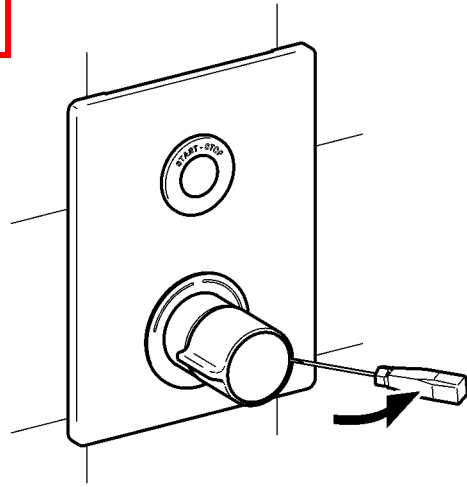

3

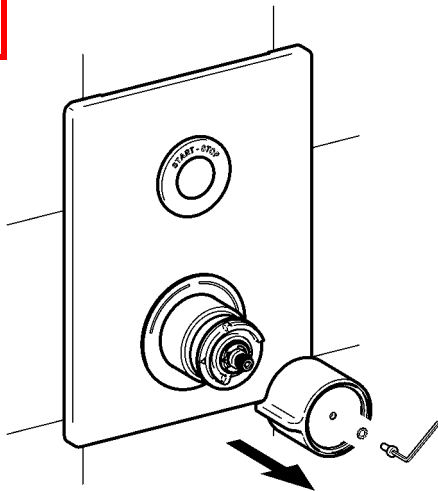

4

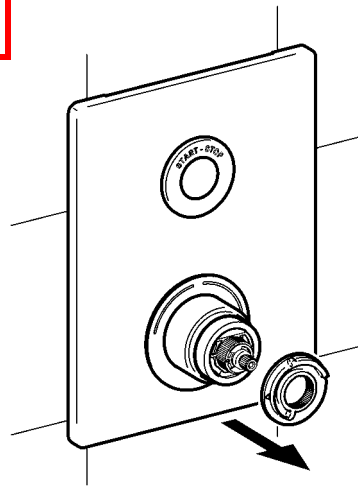

5

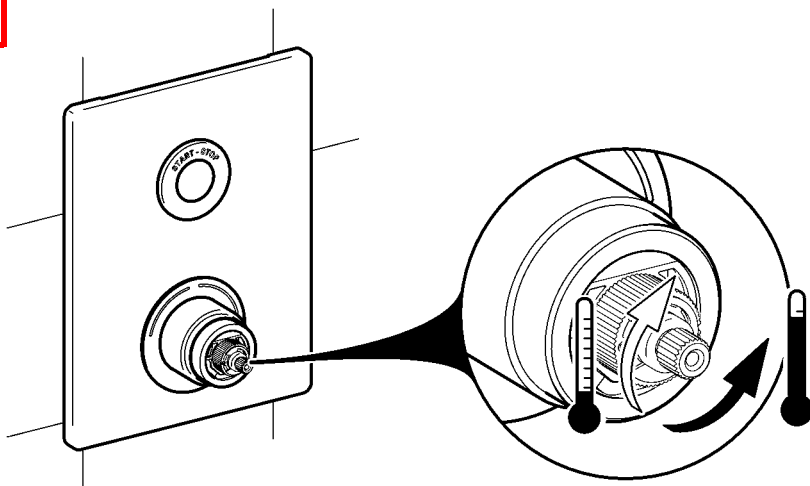

6

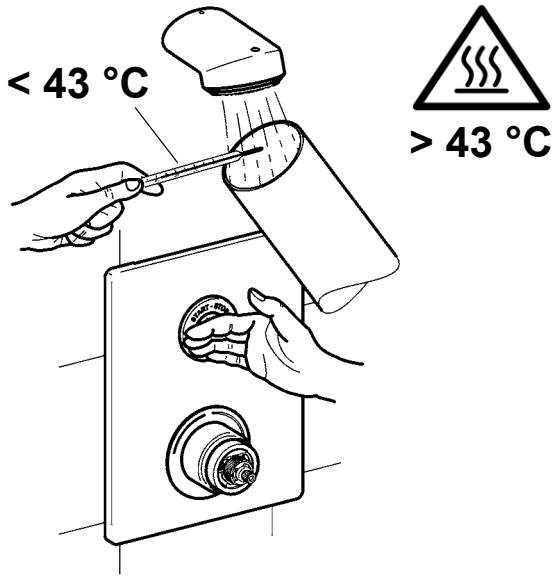

7

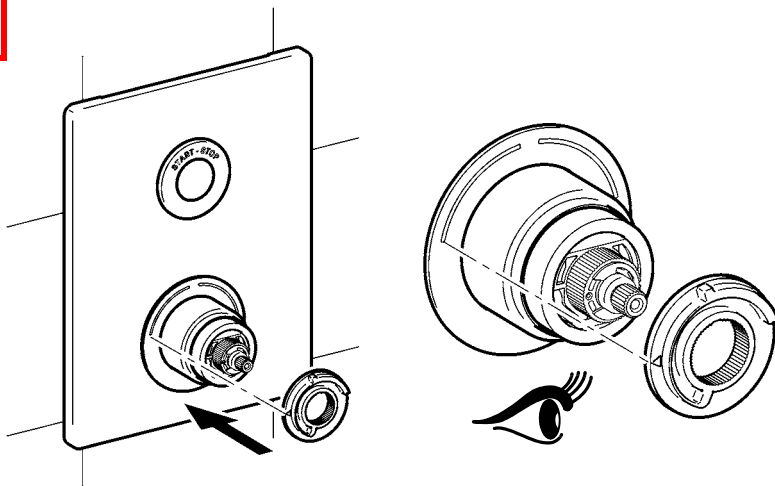

8

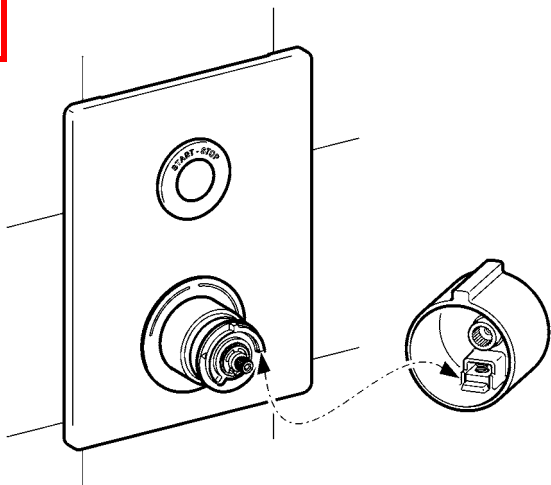

9

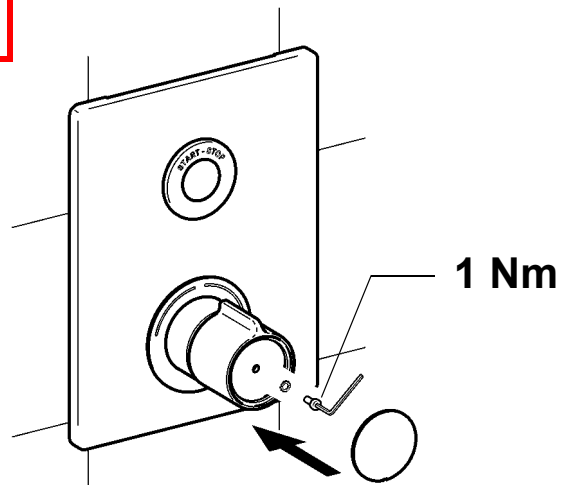

10. Thermische Desinfektion nachrüsten – elektrisch

EN Retrofit thermal disinfection	NL Thermische desinfectie monteren	CS Dodatečné vybavení tepelnou dezinfekcí
FR Montage ultérieure de la désinfection thermique	PL Doposażyc dezynfekcję termiczną	FI Lämpödesinfiointin jälkivarustelu
ES Reequipar la desinfección térmica	SV Eftermontera termisk desinfektion	RU Дооснащение термической дезинфекции
IT Montaggio successivo disinfezione termica		



24.

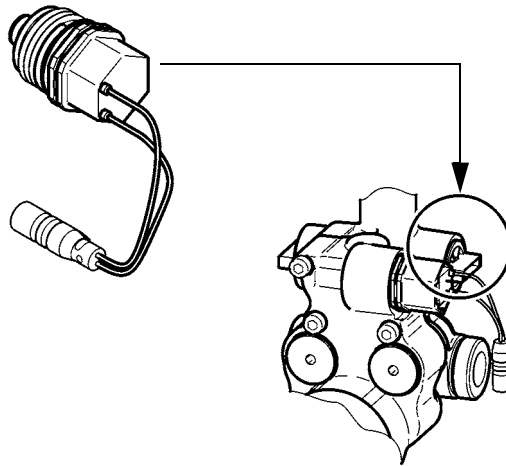

EN Not included in scope of delivery

PL poza zakresem dostawy

FR non compris dans la livraison

ES no forma parte del volumen de suministro

IT Non compreso nella fornitura

NL niet bij levering inbegrepen

DE nicht Lieferumfang

SV ngår ej i leveransen

CS Není součástí dodávky

FI ei kuulu toimitukseen

RU Не входит в объём поставки

11. Kaltwasserspülung nachrüsten

EN Retrofit cold water flush	NL Koudwaterspoeling monteren	CS Dodatečné vybavení proplachování studenou vodou
FR Montage le système de rinçage à l'eau froide	PL Doposażyc splukiwania wodą zimną	FI Kylmävesihuuhtelun jälkivarustelu
ES Reequipar el enjuague de agua fría	SV Eftermontera spolning med kallt vatten	RU Дооснащение промывку холодной водой
IT Montaggio successivo del risciacquo con acqua fredda		

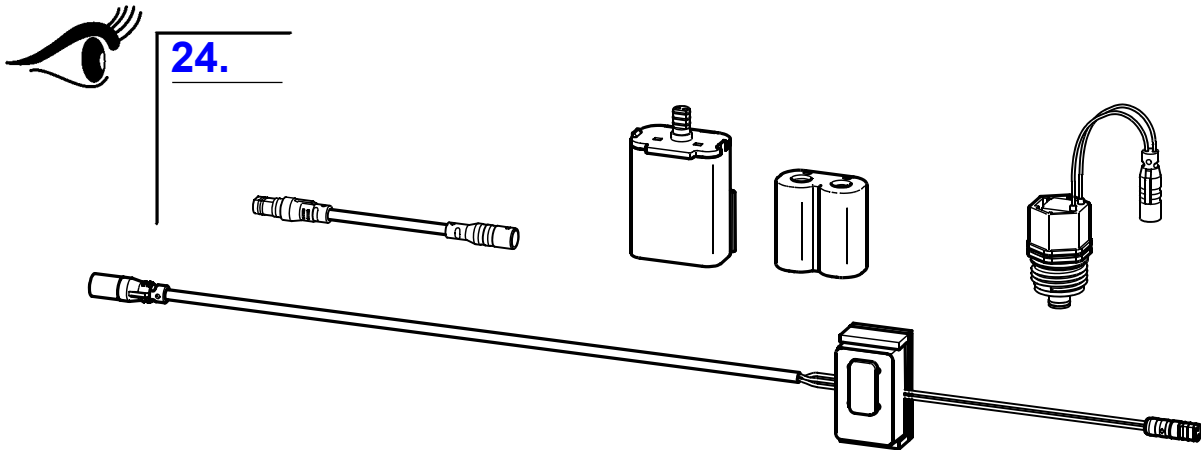

EN Not included in scope of delivery	DE nicht Lieferumfang
PL poza zakresem dostawy	SV ngår ej i leveransen
FR non compris dans la livraison	CS Není součástí dodávky
ES no forma parte del volumen de suministro	FI ei kuulu toimitukseen
IT Non compreso nella fornitura	RU Не входит в объём поставки
NL niet bij levering inbegrepen	

12. Wartung

EN Maintenance
FR Maintenance
ES Mantenimiento
IT Manutenzione

NL Onderhoud
PL Konserwacja
SV Underhåll

CS Varování
FI Huolto
RU Техническое обслуживание



15.

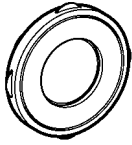

16.

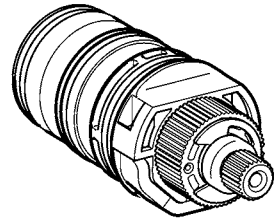

17.

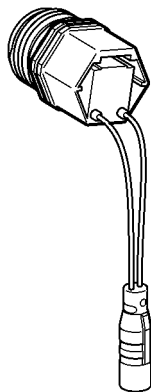

18.

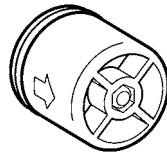

19.

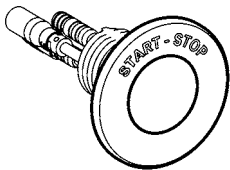

20.

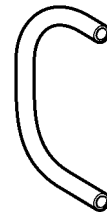

13. Abdeckplatte abnehmen

EN Remove the cover plate

NL Afdekplaat weghalen

CS Sejmutí krycí desky

FR Retrait de la plaque de protection

PL Zdejmowanie płytki maskującej

FI Peitelevyn irrottaminen

ES Retirar la placa cobertora

SV Avlägsna täckplattan

RU Демонтаж крышки

IT Rimozione della piastrina di copertura

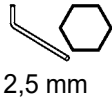

2,5 mm

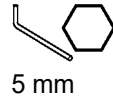

5 mm

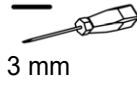

3 mm

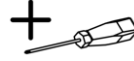

1

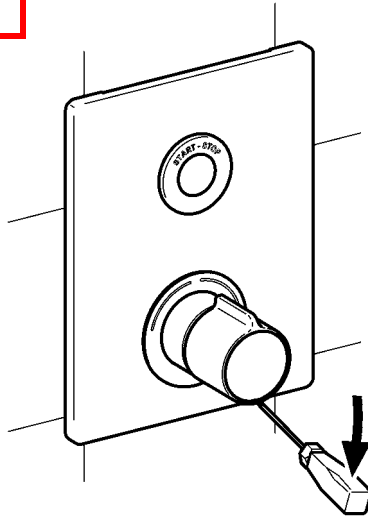

2

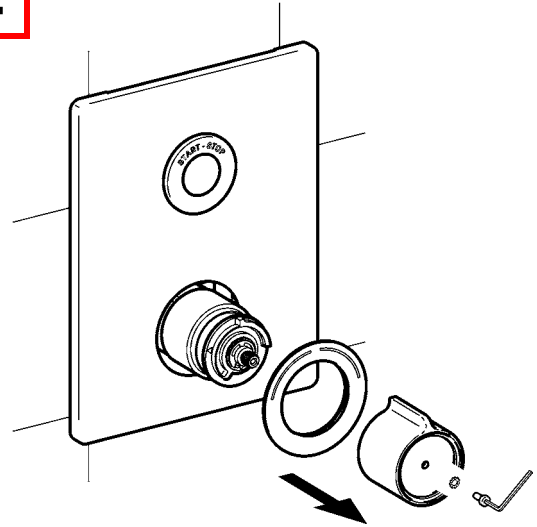

3

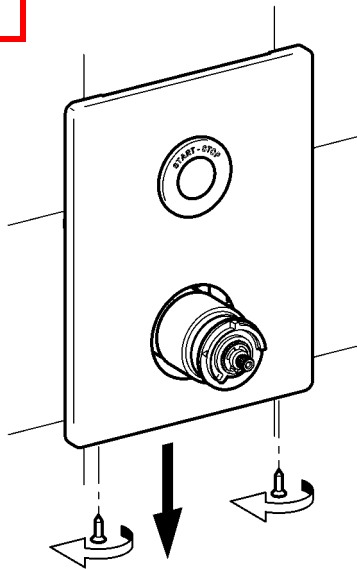

4

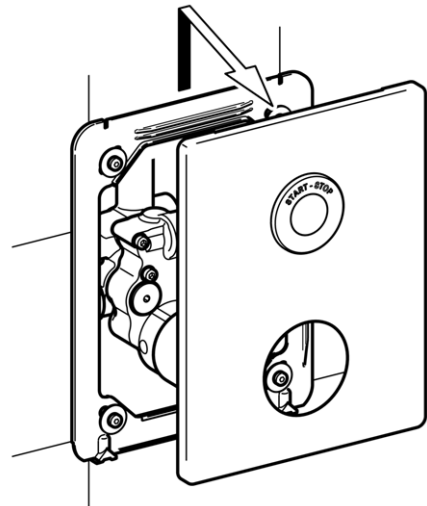

F5ET2033

5

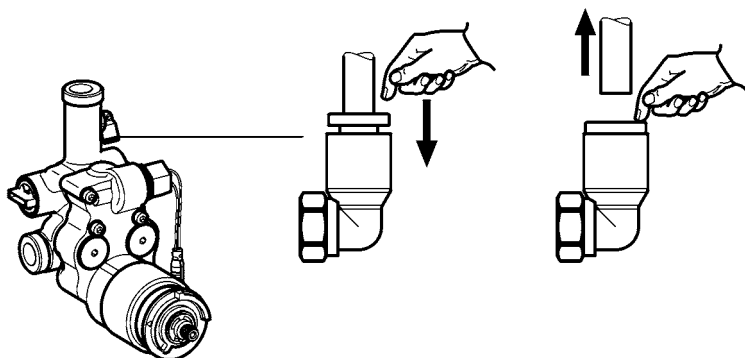

6

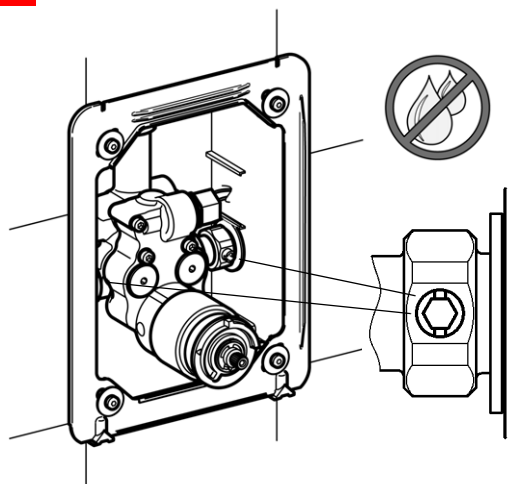

7

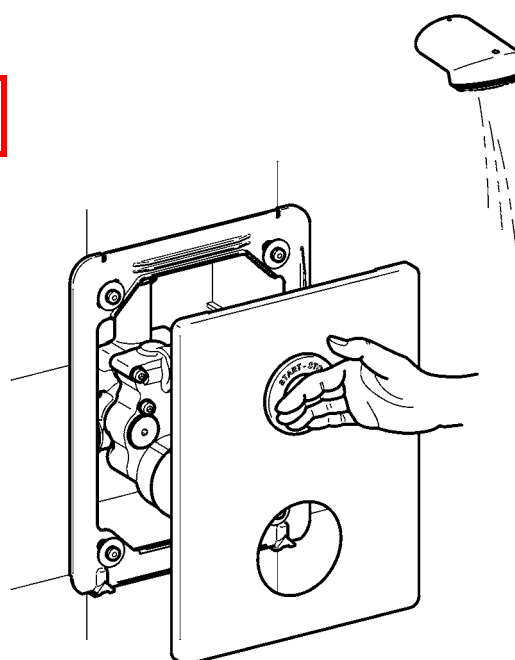

8

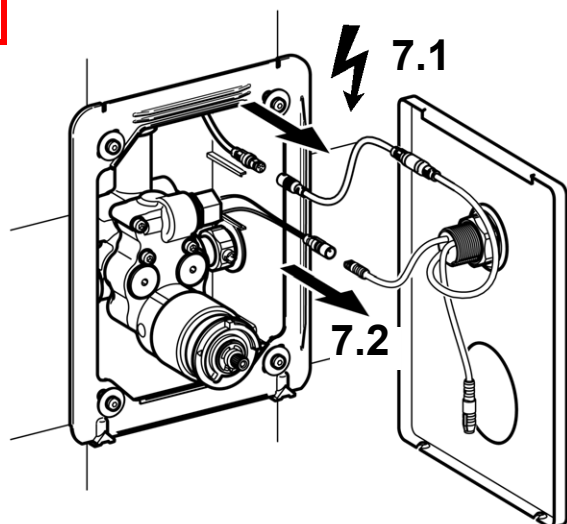

14. Abdeckplatte montieren

EN Install the cover plate

NL Afdekplaat monteren

CS Montáž krycí desky

FR Montage de la plaque de protection

PL Montaż płytki maskującej

FI Peitelevyn asennus

ES Montar la placa cobertora

SV Montera täckplattan

RU Установка крышки

IT Montaggio della piastrina di copertura

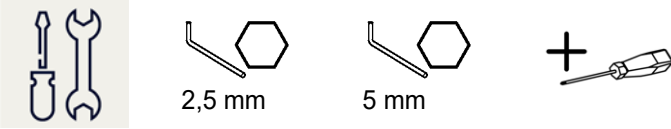

1

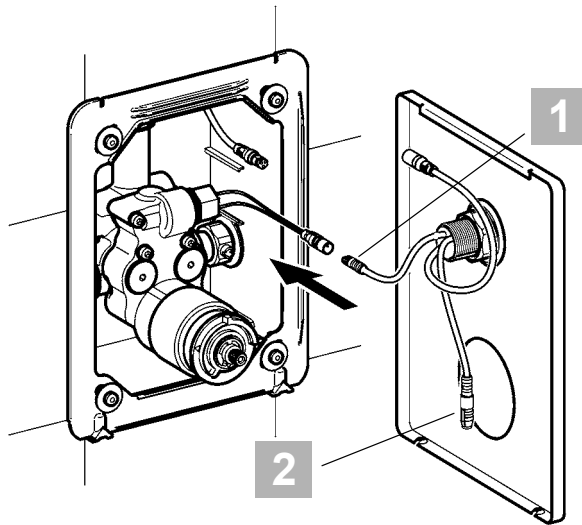

EN 1: Black
2: Red

PL 1: Czarny
2: Czerwony

DE 1: Schwarz
2: Rot

SV 1: Svart
2: Röd

FR 1: Noir
2: Rouge

CS 1: černá
2: Červený

ES 1: Negro
2: Rojo

FI 1: Musta
2: Punainen

IT 1: Nero
2: Rosso

RU 1: черный
2: красный

NL 1: Zwart
2: Rood

2

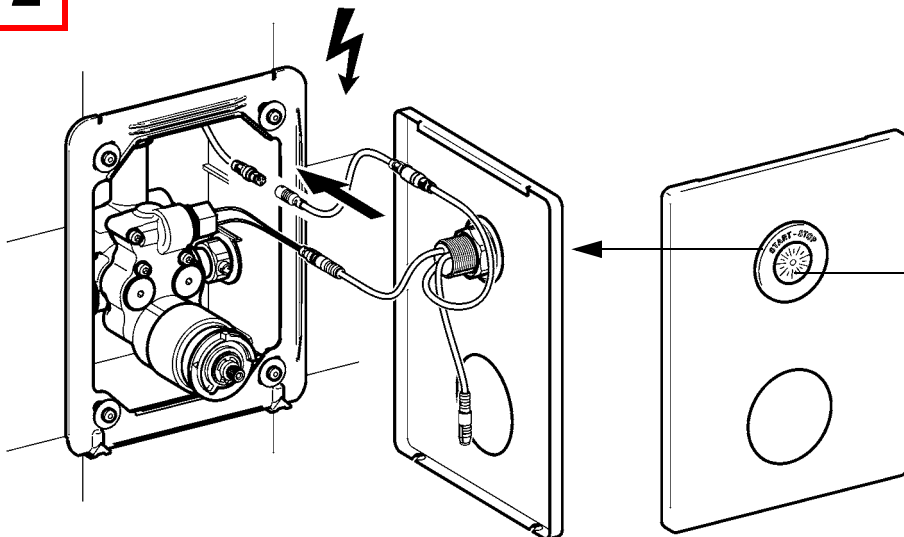

2x 

1x 



3.

A

B

3

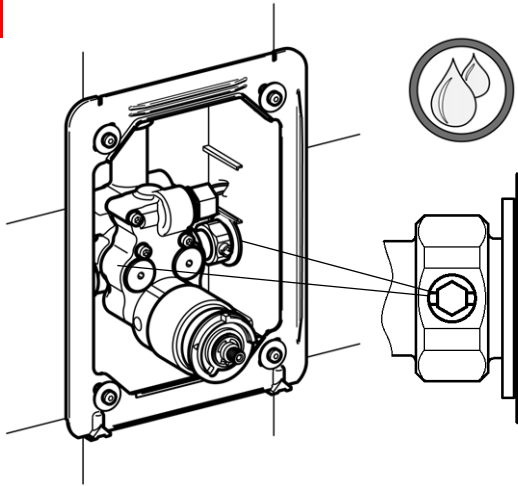

F5ET2033

4

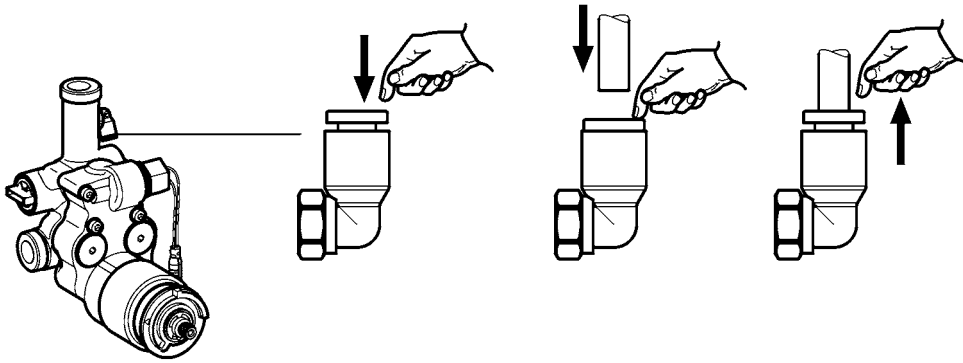

5

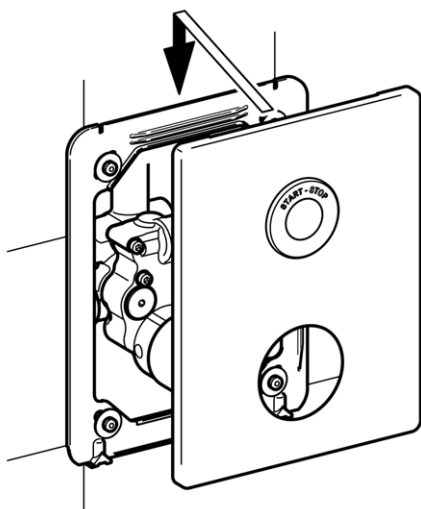

6

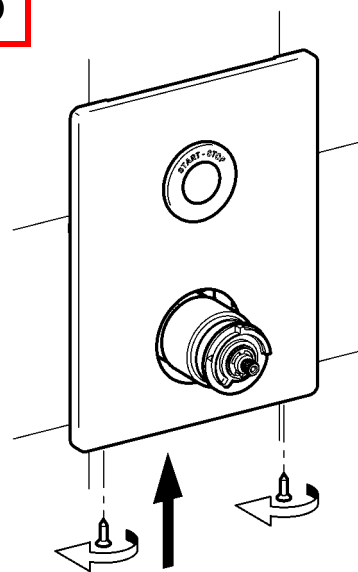

7

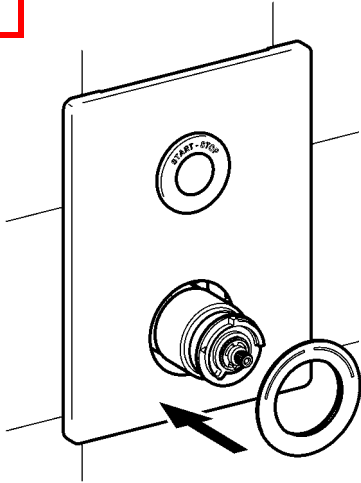

8

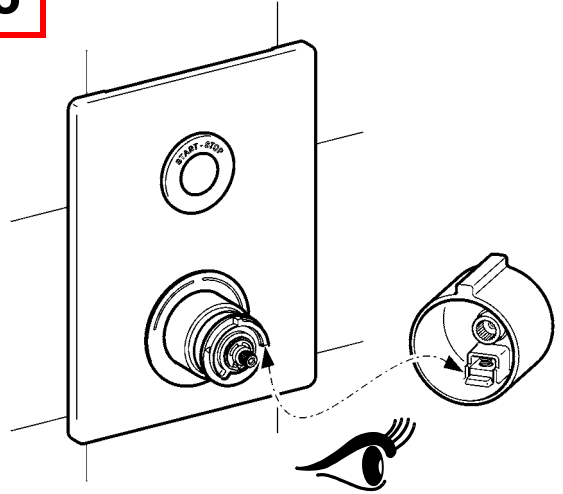

9

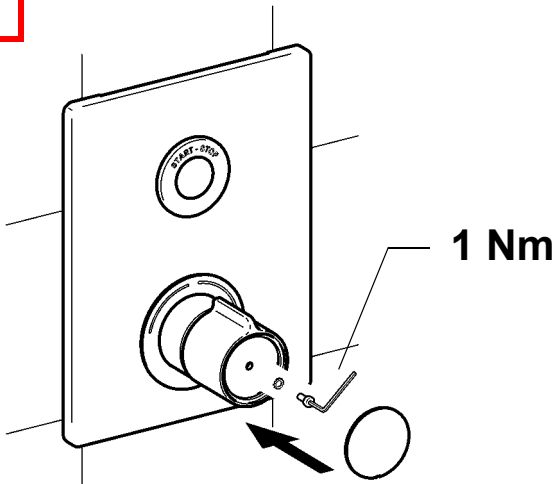

15. Siebe wechseln

EN Replace the filters
 FR Remplacement les filtres
 ES Cambiar los tamices
 IT Sostituire i filtri

NL Zeven vervangen
 PL Wymiana sit
 SV Byt filter

CS Vyměňte síto
 FI Siivilän vaihto
 RU Сменить сеточки

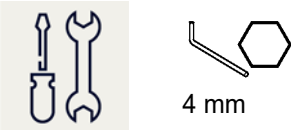

1

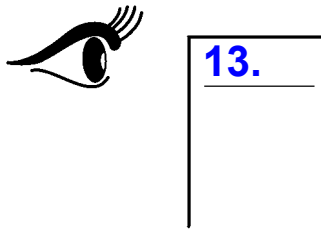

2

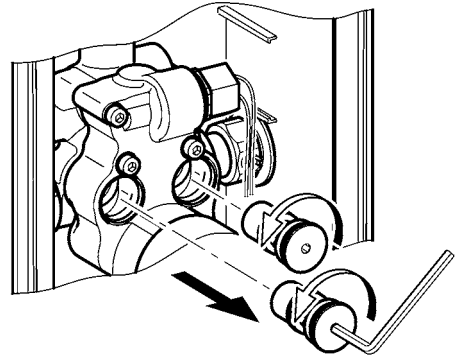

3

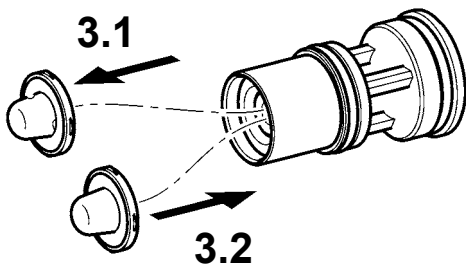

4

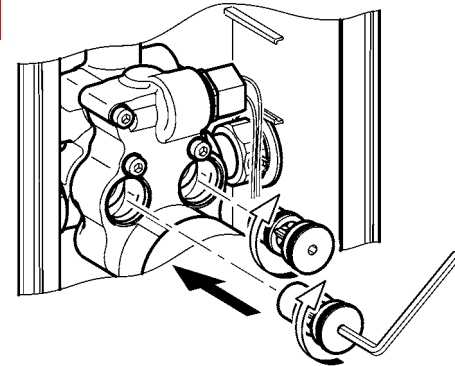

5

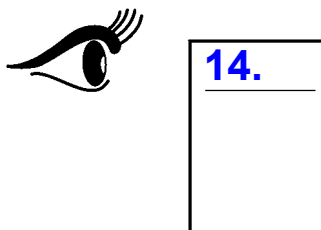

16. Thermostatkartusche wechseln

EN Changing the thermostat cartridge	NL Thermostaatcartridge vervangen	CS Výměna zásobníku termostatu
FR Remplacement de la cartouche du thermostat	PL Wymiana głowicy termostatycznej	FI Termostaattipatruunan vaihtaminen
ES Cambio del cartucho de termostato	SV Byta termostatpatron	RU Замена картриджа термостата
IT Sostituzione della cartuccia termostatica		



EN

Warning

After installing the fitting or removing the thermocouple, adjust the scald protector. Failure to observe can cause bodily harm due to scalding.

DE

Warnung

Nach Montage der Armatur oder Demontage des Thermoelements den Verbrühungsschutz einstellen. Nichtbeachtung kann Körperverletzung durch Verbrühung bewirken.

FR

Avertissement

Après le montage du robinet ou le démontage du thermocouple, régler la protection contre les échaudures. Le non-respect est susceptible de provoquer des blessures corporelles par échaudure.

ES

Aviso

Tras montar la grifería o después de desmontar el termoelemento, ajustar la protección contra escaldaduras. La no observación puede tener como consecuencia escaldaduras.

IT

Avvertenza

Al termine del montaggio della rubinetteria o dopo lo smontaggio del termoelemento, impostare la protezione antiscottatura. La non osservanza può causare ustioni.

NL

Waarschuwing

Na de montage van de armatuur of demontage van het thermische element de bescherming tegen verbranding instellen. Veronachtzaming kan letsel door verbranden veroorzaken.

PL

Ostrzeżenie

Po zamontowaniu baterii lub demontażu termoogniwa należy ustawić zabezpieczenie przed poparzeniem. Nieprzestrzeganie tego zalecenia może prowadzić do urazów ciała spowodowanych poparzeniem.

SV

Varning

Ställ in skållningsskyddet efter montering av armaturen eller demontering av termoelementet. Om detta inte efterföljs finns det risk för skållningsskador.

CS

Varování

Po montáži armatury nebo demontáži termočlánku nastavte ochranu proti opaření. Nerespektování může vést k poranění opařením.

FI

Varoitus

Laitteiston asennuksen tai lämpöelementin purkamisen jälkeen asenna palovammasuoja. Huomioon ottamatta jättäminen voi saada aikaan vartalovamman palovammasta.

RU

Предупреждение

После монтажа арматуры или демонтажа термoelementa настроить защиту от ошпаривания. Вследствие несоблюдения данного указания возможно нанесение вреда здоровью в результате ошпаривания.

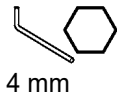

4 mm

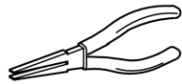

1



13.

2

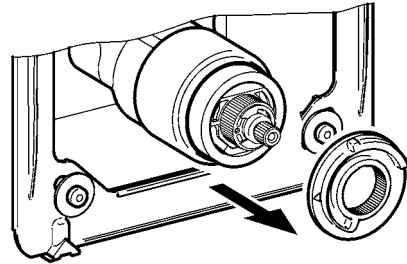

3

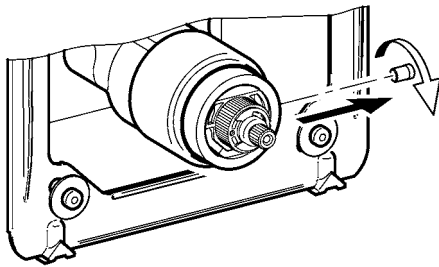

4

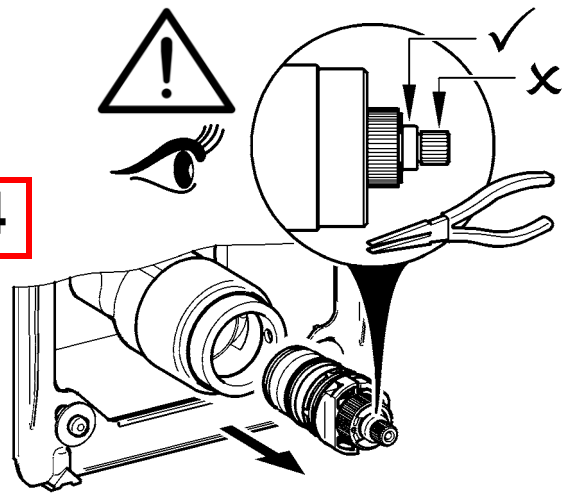

5

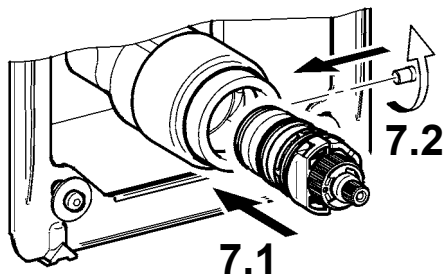

6



14.

1 - 7

7



9.

5 - 9



> 43 °C

17. Magnetventilkartusche wechseln

EN Replacing the solenoid valve cartridge	NL Magneetventielpatroon verandering	CS Výměna kartuše s magnetickým ventilem
FR Remplacement de la cartouche d'électrovanne	PL Wymiana wkładu zaworu elektromagnetycznego	FI Magneettiventtiilipanosen vaihtaminen
ES Cambiar cartucho de la válvula electromagnética	SV Byta magnetventilpatron	RU Замена картриджа электромагнитного клапана
IT Sostituzione della cartuccia della valvola elettromagnetica		



1



13.

2

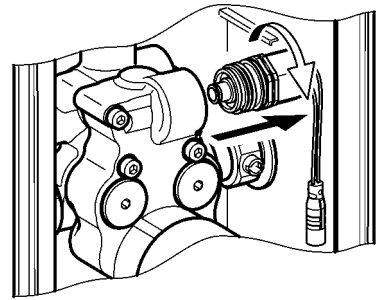

3

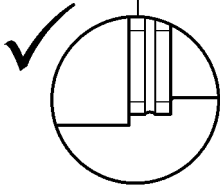
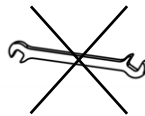
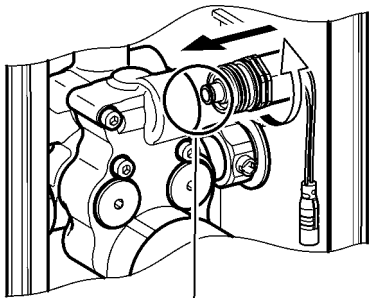

X

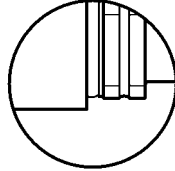

4



14.

18. Rückflussverhinderer wechseln

EN Replace the return flow inhibitor

NL Terugstroomklep vervangen

CS Vyměňte zábranu zpětného průtoku

FR Remplacement du clapet de non-retour

PL Wymiana zaworu zwrotnego

FI Paluuvirtausestäjän vaihto

ES Reemplazar la válvula antiretorno

SV Byt återströmningskydd

RU Заменить клапан обратного течения

IT Sostituire la valvola antiriflusso

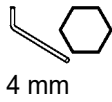

4 mm

1



13.

2

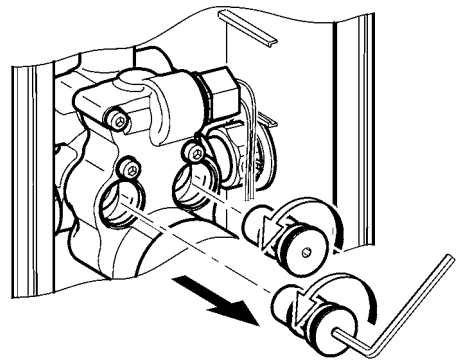

3

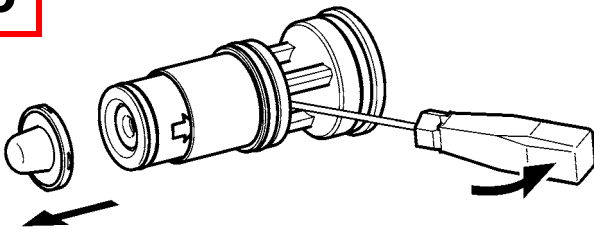

4

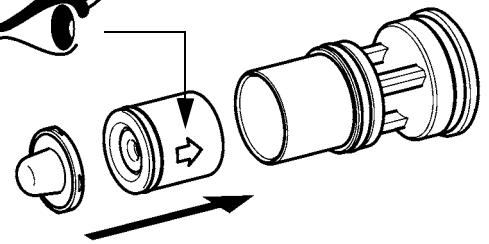

5

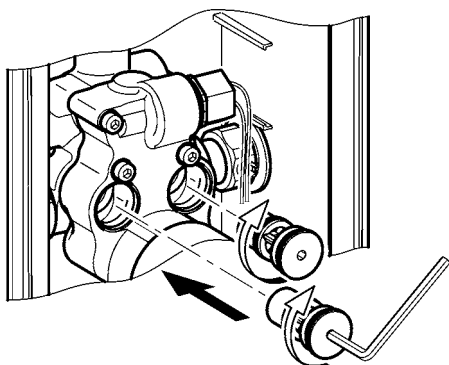

6



14.

19. Sensor wechseln

EN Replace sensor
FR Changer le capteur
ES Cambiar el sensor
IT Cambiare il sensore

NL Sensor vervangen
PL Wymienić czujnik
SV Byt sensor

CS Vyměňte snímač
FI Anturi vaihto
RU Замена Датчик



32 mm

1



13.

2

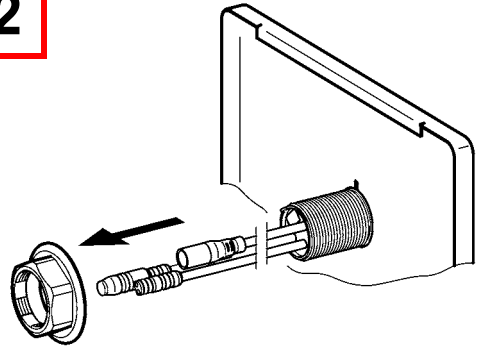

3

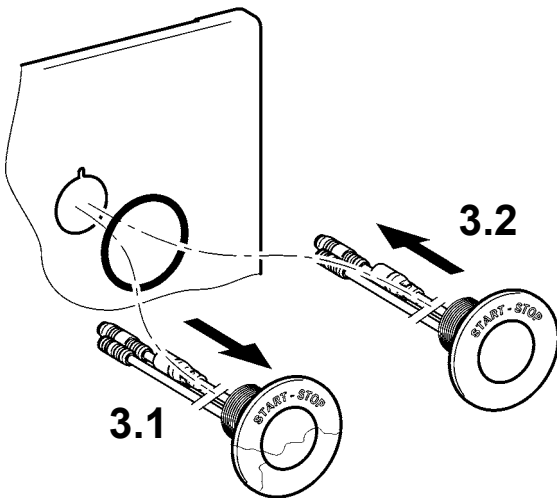

4

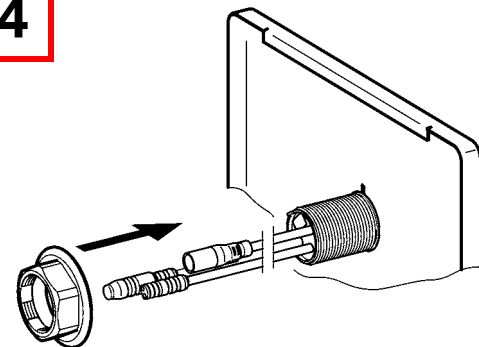

5



14.

20. Schlauch wechseln

EN Replace the hose

FR Remplacement du flexible

ES Cambio del tubo

IT Sostituzione del flessibile

NL Slang vervangen

PL Wymiana węża

SV Byta slang

CS Výměna hadice

FI Letkun vaihto

RU Замена шланга



1



13.

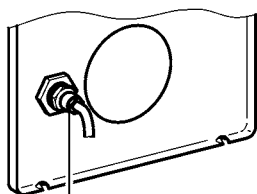

2

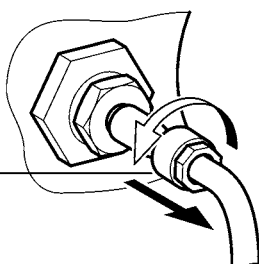

3

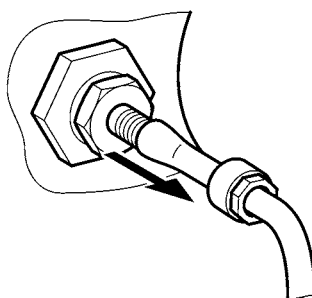

4

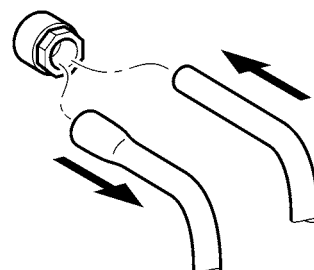

5

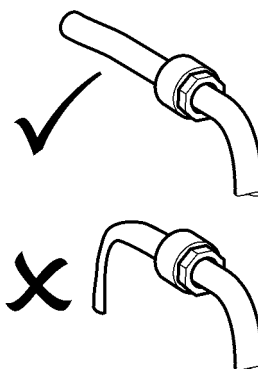
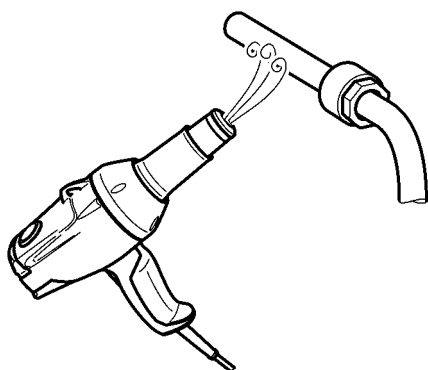

6

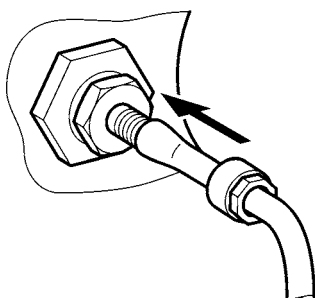

7

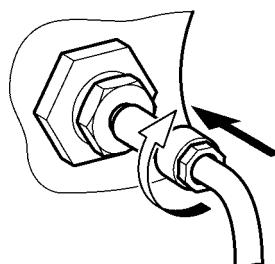

8



14.

21. Ersatzteile I

EN Replacement parts
FR Pièces de rechange
ES Piezas de recambio
IT Pezzi di ricambio

NL Reserveonderdelen
PL Części zamienne
SV Reservdelar

CS Náhradní díly
FI Varaosat
RU Запчасти

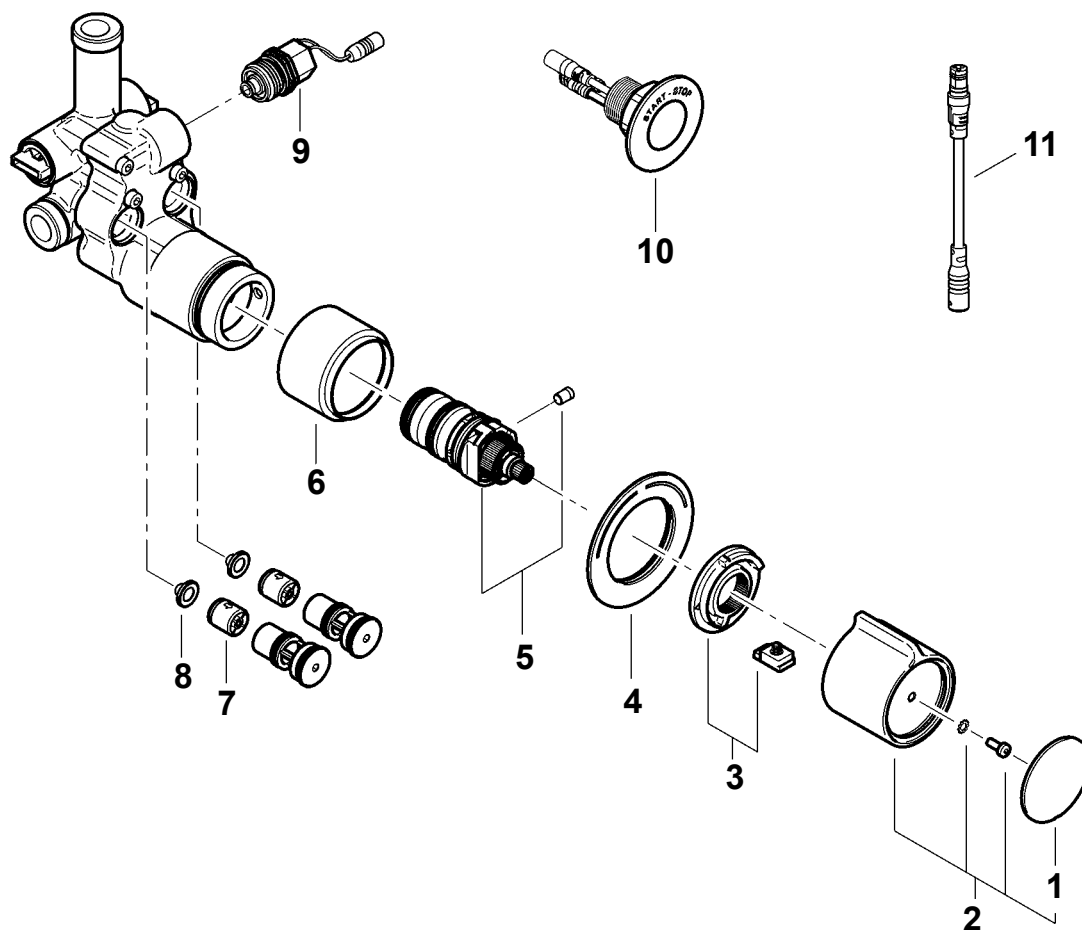

1..... 2030003258
EAQLT0002
2..... 2030047082
ASXT9003
3..... 2030003296
EAQLT0003
4..... 2030068479
ASXT9006

5 2030061611
ASXT2002
6 2030072234
ASXT2004
7 2000104687 a)
ASXX9010
8 2000104720 b)
ASXX1012

9 2030003033
EAQFU0001
10 .. 2030060302
ASET2013
11 .. 2030055550
ACEX9012

EN a) 2 pieces
b) 10 pieces

ES a) 2 piezas
b) 10 piezas

PL a) 2 sztuk
b) 10 sztuk

FI a) 2 kappaletta
b) 10 kappaletta

DE a) 2 Stück
b) 10 Stück

IT a) 2 pezzi
b) 10 pezzi

SV a) 2 styck
b) 10 styck

RU a) 2 штук
b) 10 штук

FR a) 2 pièces
b) 10 pièces

NL b) 2 stuk
b) 10 stuk

CS a) 2 kusů
b) 10 kusů

22. Ersatzteile II

EN Replacement parts
FR Pièces de rechange
ES Piezas de recambio
IT Pezzi di ricambio

NL Reserveonderdelen
PL Części zamienne
SV Reservdelar

CS Náhradní díly
FI Varaosat
RU Запчасти

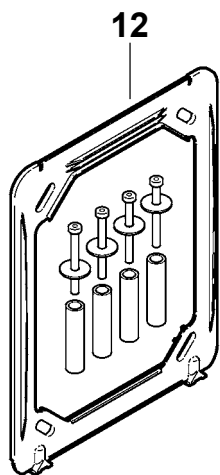

12 ...2030045472
ASXX9001

13 ...2030072723
ASET2024

14 ...2030068503
ASET2017

15 ...2000105133
ESHOW0069

16 ...1m:
2000106114
ESHOW0070

F5ET2031

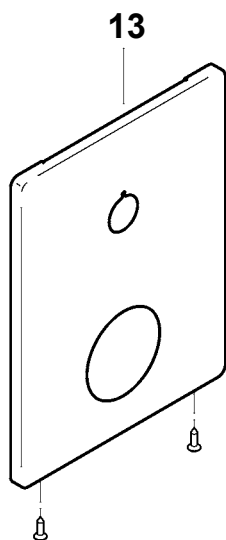

F5ET2033

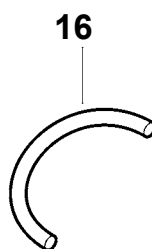
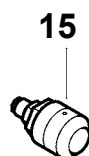
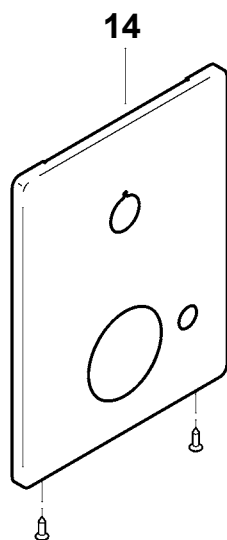

23. Zubehör I

EN Accessories
FR Accessoire
ES Accesorios
IT Accessori

NL Toebehoren
PL Akcesoria
SV Tillbehör

CS Příslušenství
FI Lisävarusteet
RU принадлежности

1

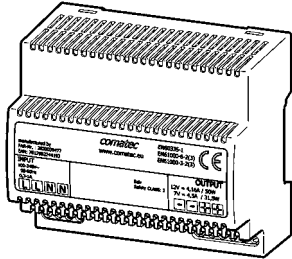

2

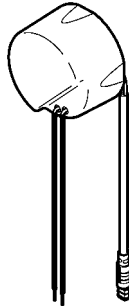

1 2030039477
ACEX9001

2 2030039825
ACEX9003

3 2000104846
EPRTR0008

4 2000109466
ZAQCT0003

5 2030041918
ACET2001

6 **5 m:**
2030043814
ACEX9010

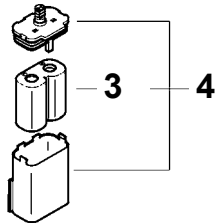

5

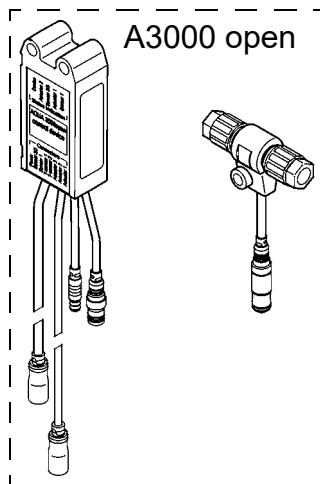

6

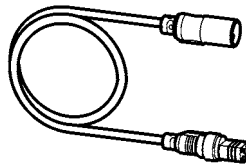

24. Zubehör II

EN Accessories
FR Accessoire
ES Accesorios
IT Accessori

NL Toebehoren
PL Akcesoria
SV Tillbehör

CS Příslušenství
FI Lisävarusteet
RU принадлежности

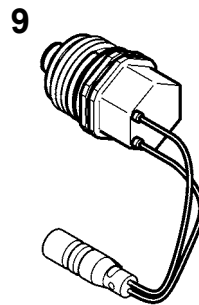
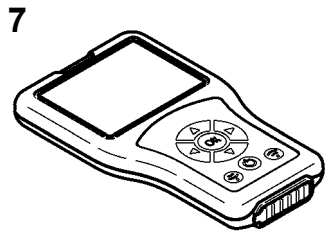

7 2030036654
ACEX9005

8 2030036849
ACEX9004

9 2030003033
EAQFU0001

10 .. 2030067889
ACXT9001

11... 2000109019
ZWSPL0024

12 .. **0,5 l:**
2000105091
ZWSPL0023

13 .. 2030071564
ACXT2005

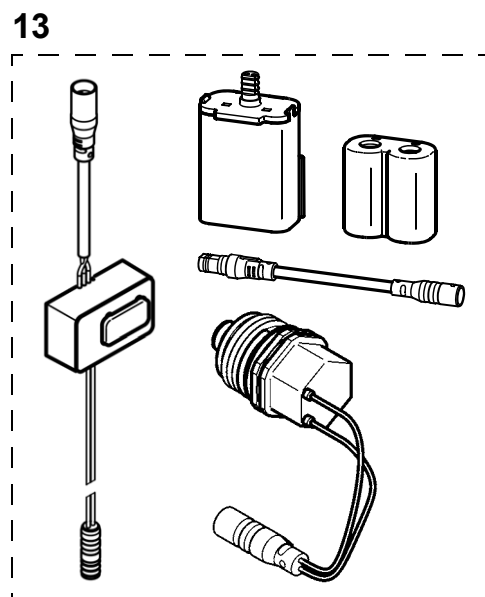
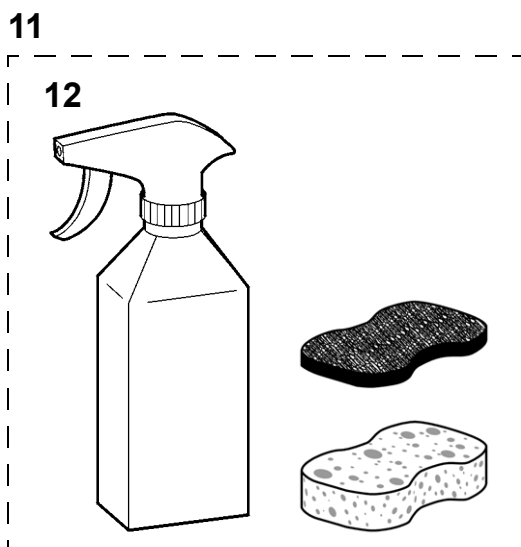
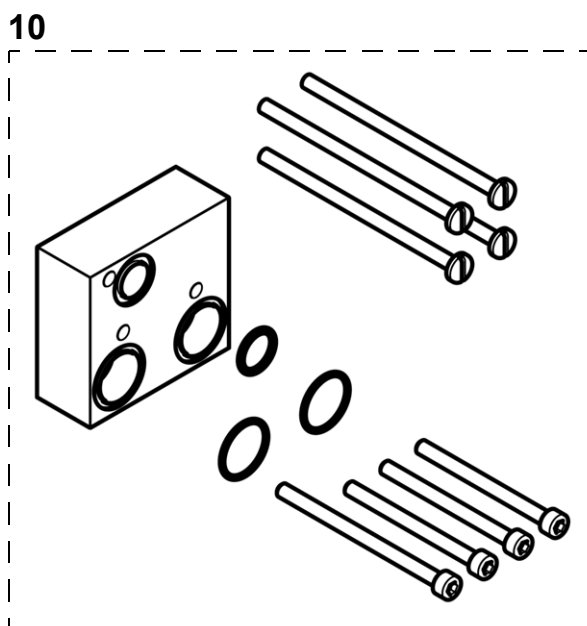

Australia

PR Kitchen and
Water Systems Pty Ltd
Dandenong South VIC 3175
Phone +61 3 9700 9100

Austria

KWC Austria GmbH
6971 Hard, Austria
Phone +43 5574 6735 0

**Belgium, Netherlands &
Luxembourg**

KWC Aquarotter GmbH
9320 Aalst; Belgium
Phone +31 (0) 492 728 224

Czech Republic

KWC Aquarotter GmbH
14974 Ludwigsfelde, Germany
Phone +49 3378 818 309

France

KWC Austria GmbH
6971 Hard, Austria
Phone +33 800 909 216

Germany

KWC Aquarotter GmbH
14974 Ludwigsfelde
Phone +49 3378 818 0

Italy

KWC Austria GmbH
6971 Hard, Austria
Numero Verde +39 800 789 233

Middle East

KWC ME LLC Ras Al Khaimah,
United Arab Emirates
Phone +971 7 2034 700

Poland

KWC Aquarotter GmbH
14974 Ludwigsfelde, Germany
Phone +48 58 35 19 700

Spain

KWC Austria GmbH
6971 Hard, Austria
Phone +43 5574 6735 211

Switzerland & Liechtenstein

KWC Group AG
5726 Unterkulm, Switzerland
Phone +41 62 768 69 00

Turkey

KWC ME LLC Ras Al Khaimah,
United Arab Emirates
Phone +971 7 2034 700

United Kingdom

KWC DVS Ltd - Northern Office
Barlborough S43 4PZ
Phone +44 1246 450 255

KWC DVS Ltd - Southern Office
Paignton TQ4 7TW
Phone +44 1803 529 021

EAST EUROPE

Bosnia Herzegovina
Bulgaria | Croatia
Hungary | Latvia
Lithuania | Romania
Russia | Serbia | Slovakia
Slovenia | Ukraine

KWC Aquarotter GmbH
14974 Ludwigsfelde, Germany
Phone +49 3378 818 261

SCANDINAVIA & ESTONIA

Finland | Sweden | Norway
Denmark | Estonia

KWC Nordics Oy
76850 Naarajärvi, Finland
Phone +358 15 34 111

OTHER COUNTRIES

KWC Austria GmbH
6971 Hard, Austria
Phone +43 5574 6735 0

