

F5

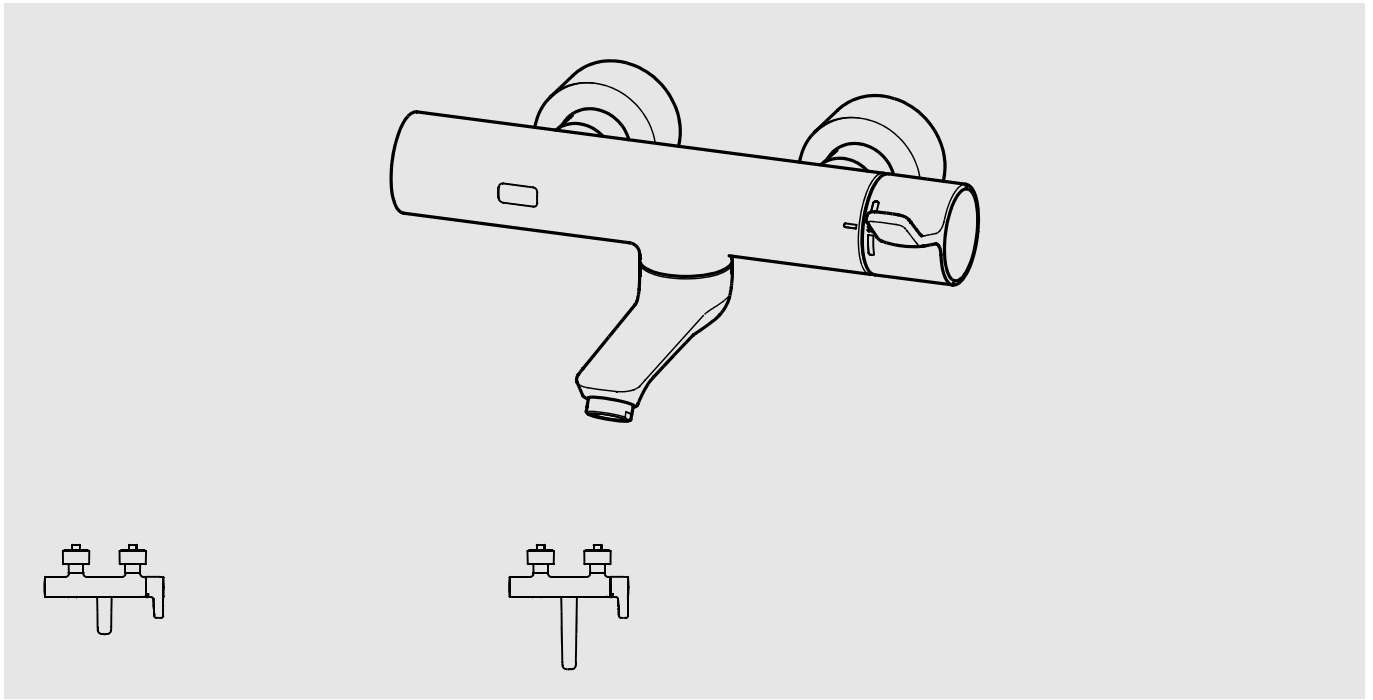

F4ET1001
2030072424

F4ET1002
2030072425

DE	Montage- und Betriebsanleitung	Elektronik-Thermostatbatterie
EN	Installation and operating instructions	Electronic thermostatic mixer
FR	Notice de montage et de mise en service	Mitigeur thermostatique électronique
ES	Instrucciones de montaje y servicio	Batería de termostato con sistema electrónico
IT	Istruzioni per il montaggio e l'uso	Miscelatore termostatico-elettronico
NL	Montage- en bedrijfsinstructies	Elektronische thermostaatmengkraan
PL	Instrukcja montażu i obsługi	Elektroniczna bateria termostat
SV	Monterings- och driftinstruktion	
CS	Návod pro montáž a provoz	
FI	Asennus- ja käyttöohje	Elektroninen termostaattihana
RU	Инструкция по монтажу и вводу в эксплуатацию	

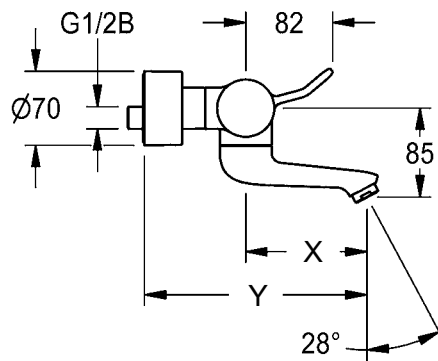
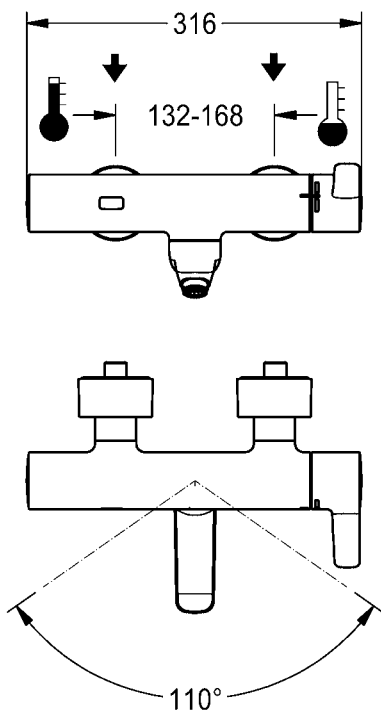
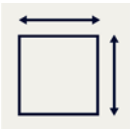
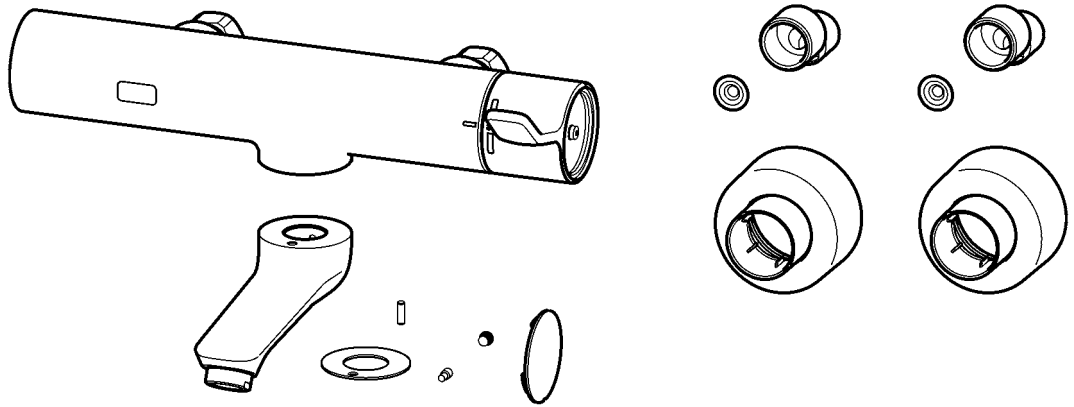

	X	Y
F4ET1001	115	210
F5ET1002	200	296

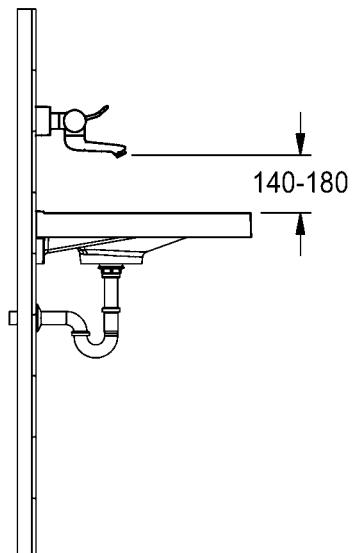
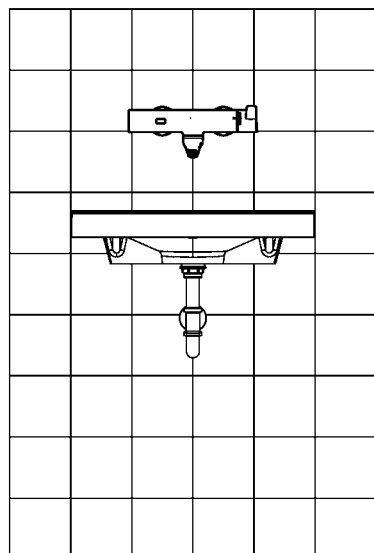

EN

Installation and operating instructions

Important notes

- ▶ Before installing flush piping system!
- ▶ Set the scald protection after assembly has been completed.
- ▶ The fitting must be operated only with original mesh filters and return flow inhibitors!
- ▶ The fitting must be checked and maintained at regular intervals depending on the water quality and in accordance with the local conditions, and rules and regulations applicable at the site.

Technical data

- ▶ Minimum flow pressure 1.0 bar
- ▶ Maximum operating pressure 10 bar
- ▶ Recommended flow pressure 1-5 bar
- ▶ Volume flow at 3 bar flow pressure 9 l/min
- ▶ Thermostatic scald protection according to DIN EN 1111
- ▶ maximum operating temperature
 - continuous operation 70 °C
 - short-term (<10 min) 80 °C
- ▶ Flow duration 10 s (adjustable)
- ▶ Voltage supply with lithium battery CRP2 6 V DC
- ▶ Power consumption 1,5 W
- ▶ Type of protection IP 59k

DE

Montage- und Betriebsanleitung

Wichtige Hinweise

- ▶ Vor Installation Rohrleitungen spülen!
- ▶ Nach erfolgter Montage den Verbrühungsschutz einstellen.
- ▶ Armatur nur mit original Sieben und Rückflussverhinderern betreiben!
- ▶ In Abhängigkeit von der Wasserqualität, den örtlichen Gegebenheiten und den vor Ort geltenden Bestimmungen die Armatur in regelmäßigen Abständen prüfen und warten.

Technische Daten

- ▶ Mindestfließdruck 1,0 bar
- ▶ Maximaler Betriebsdruck 10 bar
- ▶ Empfohlener Fließdruck 1-5 bar
- ▶ Volumenstrom bei 3 bar Fließdruck 9 l/min
- ▶ Thermostatischer Verbrühungsschutz laut DIN EN 1111
- ▶ maximale Betriebstemperatur
 - Dauerbetrieb 70 °C
 - Kurzzeit (<10 min) 80 °C
- ▶ Fließzeit 10 s (einstellbar)
- ▶ Spannungsversorgung
Lithium Batterie CRP2 6 V DC
- ▶ Leistungsaufnahme 1,5 W
- ▶ Schutzart IP 59k

Ważne wskazówki

- ▶ Przed instalacją przepłukać rury!
- ▶ Po przeprowadzeniu montażu ustawić zabezpieczenie przed poparzeniem.
- ▶ Armatury należy używać wyłącznie z oryginalnymi sitkami i zaworami zwrotnymi!
- ▶ Armaturę należy poddawać regularnej kontroli i konserwacji w zależności od jakości wody, warunków lokalnych i obowiązujących przepisów.

Dane techniczne

- ▶ Minimalne ciśnienie przepływu 1,0 bar
- ▶ Maksymalne ciśnienie robocze 10 barów
- ▶ Zalecane ciśnienie przepływu 1-5 barów
- ▶ Objętościowe natężenie przepływu przy ciśnieniu 3 barów 9 l/min
- ▶ Termostatyczne zabezpieczenie przed poparzeniem zgodnie z DIN EN 1111
- ▶ Maksymalna temperatura eksploatacji
 - Praca stała 70 °C
 - Czas krótki (<10 min) 80 °C
- ▶ Czas przepływu 10 s (z możliwością ustawienia)
- ▶ Zasilanie elektryczne baterią litową CRP2 6 V DC
- ▶ Pobór mocy 1,5 W
- ▶ Rodzaj ochrony IP 59k

Viktiga informationer

- ▶ Spola igenom rörledningarna före installation!
- ▶ Ställ in skållningsskyddet efter installationen!
- ▶ Använd armaturen endast med originalsilar och originalåterflödesförhindrare!
- ▶ Kontrollera och serva armaturen med intervaller som bestäms av vattenkvaliteten samt de lokala förhållandena och de bestämmelser som gäller där.

Tekniska data

- ▶ Minsta hydrauliska tryck 1,0 bar
- ▶ Maximalt drifttryck 10 bar
- ▶ Rekommenderat hydrauliskt tryck 1-5 bar
- ▶ Volymstrom vid 3 bar hydrauliskt tryck 9 l/min
- ▶ Termostatstyrt skållningsskydd enligt DIN EN 1111
- ▶ Maximal driftstemperatur
 - Kontinuerlig drift 70 °C
 - Kort tid (< 10 min) 80 °C
- ▶ Flyttid 10 s (inställbar)
- ▶ Spänningsförsörjning med litiumbatteri CRP2 6 V DC
- ▶ Effektbehov 1,5 W
- ▶ Skyddsklass IP 59k

FR

Notice de montage et de mise en service

Remarques importantes

- ▶ Rincer les conduites avant d'installer !
- ▶ Régler le dispositif de protection contre les brûlures après le montage.
- ▶ Ne faire fonctionner la robinetterie qu'avec les filtres et clapets de non retour d'origine !
- ▶ En fonction de la qualité de l'eau, ainsi que des conditions et des dispositions locales, il convient de contrôler et d'entretenir la robinetterie à intervalles réguliers.

Données techniques

- ▶ Pression dynamique minimale 1,0 bar
- ▶ Pression de service maximale 10 bars
- ▶ Pression dynamique recommandée 1-5 bars
- ▶ Débit volumique pour 3 bars de pression dynamique 9 l/min
- ▶ Protection thermostatique contre les échaudures selon DIN EN 1111.
- ▶ Température de fonctionnement maximale
 - Fonctionnement continu 70 °C
 - Courte période (< 10 min) 80 °C
- ▶ Durée d'écoulement 10 s (réglable)
- ▶ Alimentation en tension avec pile au lithium CRP2 6 V DC
- ▶ Puissance absorbée 1,5 W
- ▶ Type de protection IP 59k

CS

Návod pro montáž a provoz

Důležité pokyny

- ▶ Před instalací potrubí propláchněte!
- ▶ Po úspěšné montáži nastavte ochranu proti opaření.
- ▶ Provozovat armaturu jen s originálními sítky a zařízeními proti zpětnému toku!
- ▶ V závislosti na kvalitě vody, místních podmínkách a předpisech platných v místě instalace je nutné provádět v pravidelných intervalech kontrolu a údržbu armatury.

Technické údaje

- ▶ Minimální průtočný tlak 1,0 bar
- ▶ Maximální provozní tlak 10 bar
- ▶ Doporučený průtočný tlak 1-5 bar
- ▶ Průtok při průtočném tlaku 3 bar 9 l/min
- ▶ Termostatická ochrana proti opaření podle normy DIN EN 1111
- ▶ Maximální provozní teplota
 - Doba provozu 70 °C
 - Krátký čas (< 10 min.) 80 °C
- ▶ Doba průtoku 10 s (nastavitelná)
- ▶ Napájení lithiovou baterií CRP2 6 V DC
- ▶ Příkon 1,5 W
- ▶ Krytí IP 59k

ES

Instrucciones de montaje y servicio

Indicaciones importantes

- ▶ ¡Enjuagar las tuberías antes de instalar!
- ▶ Tras finalizar el montaje, ajustar la protección contra escaldaduras.
- ▶ ¡La grifería debe hacerse funcionar únicamente con los tamices y las válvulas antiretorno originales!
- ▶ En función de la calidad del agua, las condiciones locales y la legislación vigente, realizar las inspecciones y el mantenimiento de la grifería a intervalos regulares.

Datos técnicos

- ▶ Presión mínima de flujo 1,0 bar
- ▶ Presión máxima de servicio 10 bares
- ▶ Presión de flujo recomendada 1-5 bares
- ▶ Flujo volumétrico con 3 bares de presión de flujo 9 l/min
- ▶ Protección termostática frente a escaldaduras según DIN EN 1111.
- ▶ Temperatura de servicio máxima
 - Funcionamiento continuo 70 °C
 - Tiempo breve (< 10 min) 80 °C
- ▶ Tiempo de corriente 10 s (ajustable)
- ▶ Alimentación de corriente con batería de litio CRP2 6 V DC
- ▶ Consumo de potencia 1,5 W
- ▶ Modo de protección IP 59k

FI

Asennus- ja käyttöohje

Tärkeitä ohjeita

- ▶ Huuhtelee putkijohdot ennen asennusta!
- ▶ Kun asennus on tehty, säädä palovammasuoja.
- ▶ Käytä varusteet vain alkuperäisten sihtien ja takaisinvirtauksen eston kanssa!
- ▶ Hana tulee tarkistaa ja huoltaa säännöllisin väliajoin veden laadusta, paikallisista oloista ja paikalla voimassa olevista määräyksistä riippuen.

Tekniset tiedot

- ▶ Vähimmäisvirtauspaine 1,0 bar
- ▶ Suurin käyttöpaino 10 bar
- ▶ Suositeltava virtauspaine 1-5 bar
- ▶ Tilavuusvirta 3 barin virtauspaineella 9 l/min
- ▶ Termostaattinen kuumavesisuoja DIN EN 1111 mukaan
- ▶ Maksimaalinen käyttölämpötila
 - Jatkuva käyttö 70 °C
 - Lyhyt aika (<10 min) 80 °C
- ▶ Juoksuaika 10 s (säädettävissä)
- ▶ Jännitteensyöttö litiumparistolla CRP2 6 V DC
- ▶ Tehonkulutus 1,5 W
- ▶ Suojaustapa IP 59k

IT

Istruzioni per il montaggio e l'uso

Avvertenze importanti

- ▶ Sciacquare le tubazioni prima di installare!
- ▶ A montaggio avvenuto impostare la protezione dalle scottature.
- ▶ Utilizzare la rubinetteria esclusivamente con i filtri e le valvole antiriflusso originali!
- ▶ Controllare e sottoporre a manutenzione l'apparecchio ad intervalli regolari, in funzione della qualità dell'acqua, delle caratteristiche locali e delle vigenti disposizioni locali.

Specifiche tecniche

- ▶ Pressione idraulica min. 1,0 bar
- ▶ Pressione di esercizio max. 10 bar
- ▶ Pressione idraulica consigliata 1-5 bar
- ▶ Portata volumetrica a 3 bar di pressione idraulica 9 l/min
- ▶ Protezione antiscottatura termostatica secondo DIN EN 1111.
- ▶ Temperatura massima di esercizio
 - Funzionamento continuo 70 °C
 - Brevemente (<10 min) 80 °C
- ▶ Durata di flusso da 10 s (impostabile)
- ▶ Alimentazione di tensione con batteria al litio CRP 2 di 6 V DC
- ▶ Potenza assorbita 1,5 W
- ▶ Tipo di protezione IP 59k

RU

Инструкция по монтажу и вводу в эксплуатацию

Важные указания

- ▶ Перед инсталляцией промыть трубки!
- ▶ После произведенного монтажа настроить защиту от ожогов.
- ▶ Эксплуатировать арматуру только с оригинальными фильтрами и клапанами обратного течения!
- ▶ Арматуру необходимо регулярно чистить и обслуживать в зависимости от качества воды, местных условий и действующих в месте эксплуатации предписаний.

Технические характеристики

- ▶ Минимальный гидравлический напор 1,0 бар
- ▶ Максимальное рабочее давление 10 бар
- ▶ Рекомендуемый гидравлический напор 1-5 бар
- ▶ Объемный расход при гидравлическом напоре 3 бар 9 л/мин
- ▶ Термостатическая система защиты от ожога горячим паром/жидкостью согласно стандарту DIN EN 1111.
- ▶ Максимальная рабочая температура
 - Непрерывный режим работы 70 °C
 - Короткое время (<10 мин) 80 °C
- ▶ Время протекания 10 сек. (регулируемое)
- ▶ Источник питания - литиевая батарея CRP 2 6 В постоянного тока
- ▶ Потребляемая мощность 1,5 Вт
- ▶ Вид защиты IP 59k

Belangrijke aanwijzingen

- ▶ Voor installatie buisleidingen spoelen!
- ▶ Na de montage de beveiliging tegen verbranding door te heet water instellen.
- ▶ Armatuur alleen met originele zeven en terugstroomkleppen gebruiken!
- ▶ Afhankelijk van de waterkwaliteit, de plaatselijke omstandigheden en de plaatselijke voorschriften de armatuur regelmatig controleren en onderhouden.

Technische gegevens

- ▶ Minimale dynamische druk 1,0 bar
- ▶ Maximale werkdruk 10 bar
- ▶ Aanbevolen dynamische druk 1-5 bar
- ▶ Volumestroom bij 3 bar dynamische druk 9 l/min
- ▶ Thermostatische beveiliging tegen verbranding volgens DIN EN 1111.
- ▶ Maximale bedrijfstemperatuur
 - Continubedrijf 70 °C
 - Kortstondig (<10 min) 80 °C
- ▶ Stromingstijd 10 s (instelbaar)
- ▶ Spanningsvoorziening d.m.v. lithiumbatterij CRP2 6 V DC
- ▶ Opgenomen vermogen 1,5 W
- ▶ Veiligheidsgraad IP 59k



1. Montage

EN Installation
FR Montage
ES Montaje
IT Montaggio

NL Montage
PL Montaż
SV Montering

CS Montáž
FI Asennus
RU Монтаж

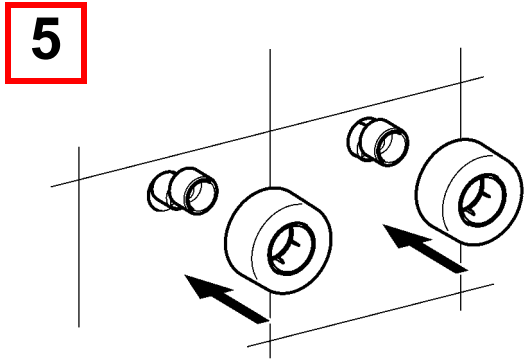
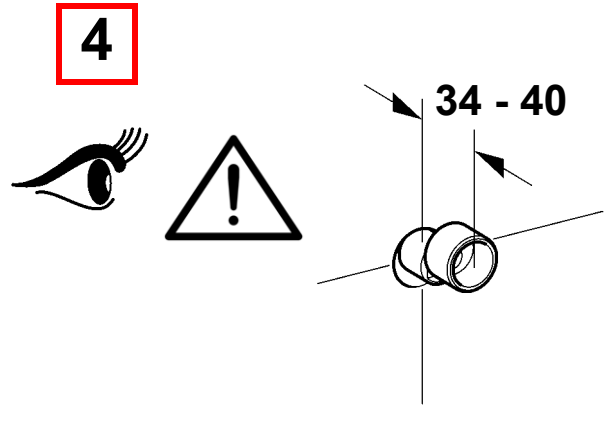
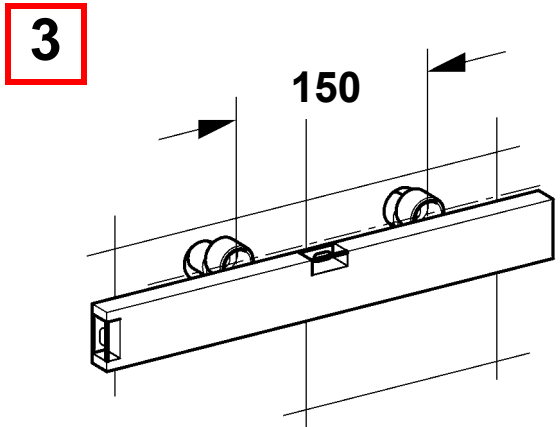
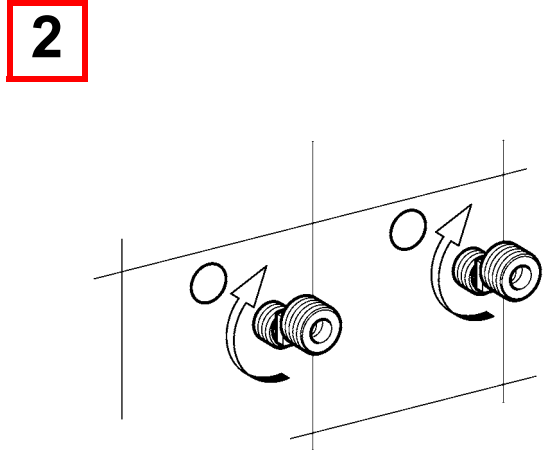
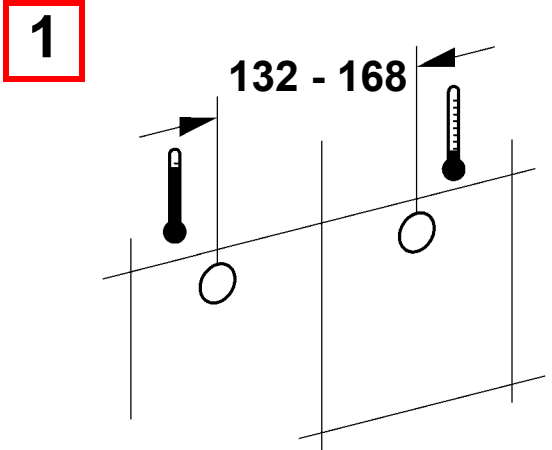

6

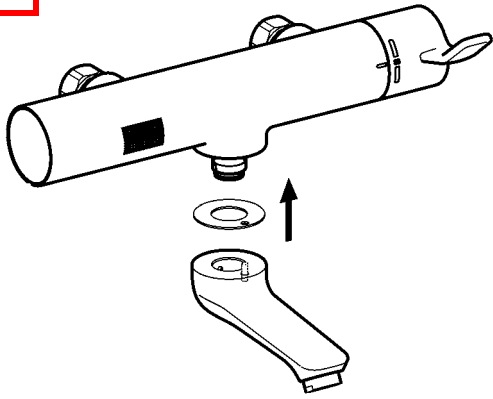

I

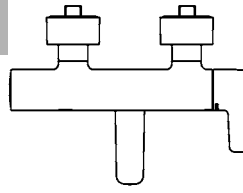

II

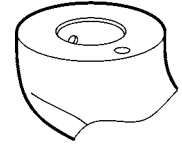
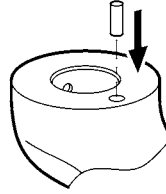
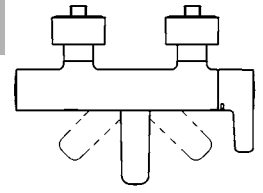

7

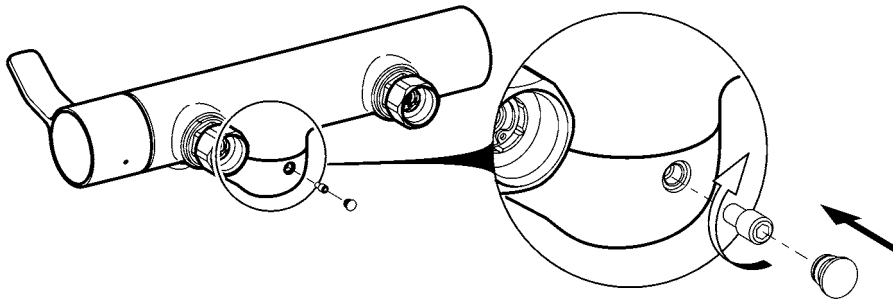

8

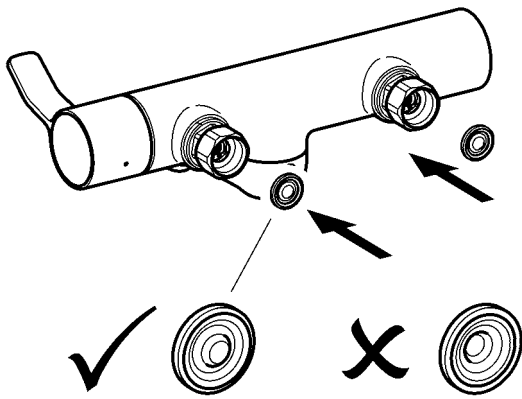

9

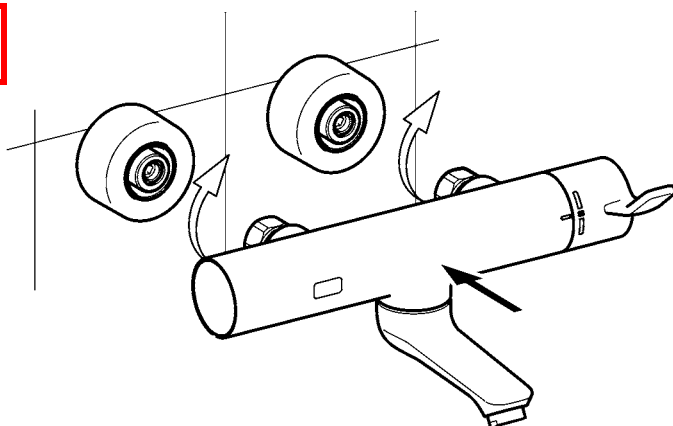

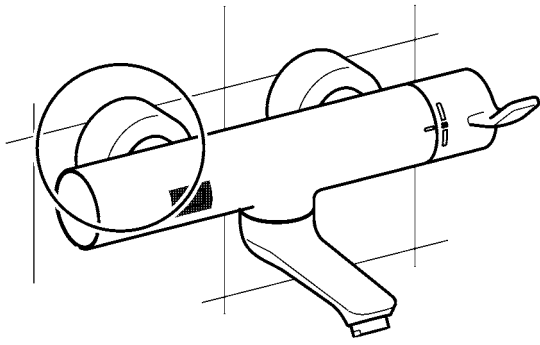

10

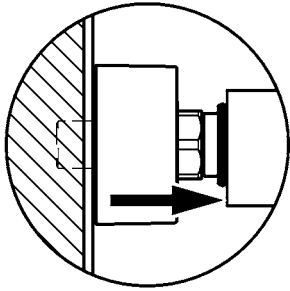

11

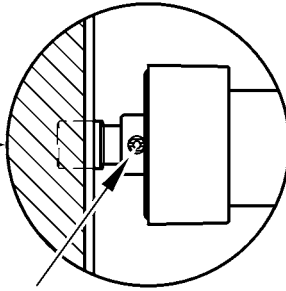

12

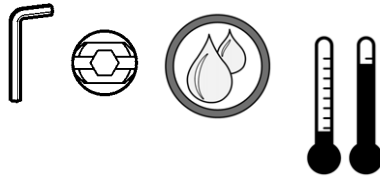
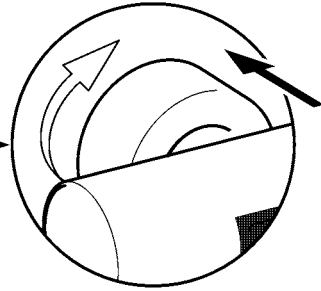

13

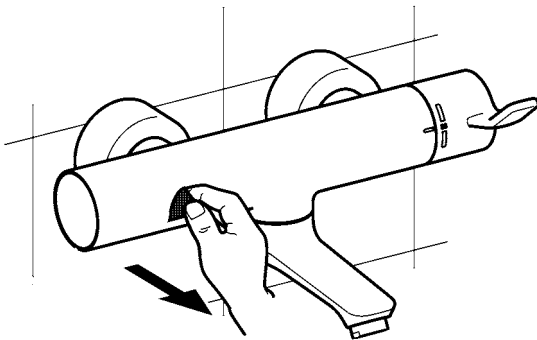

14



> 43 °C

12.

3 - 9

2. Funktion

EN Function
FR Fonctionnement
ES Función
IT Funzionamento

NL Werking
PL Funkcja
SV Funktion

CS Funkce
FI Toiminto
RU Функционирование

1

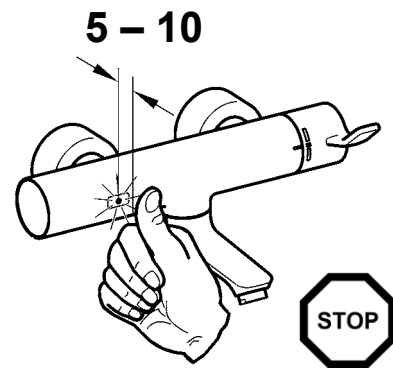
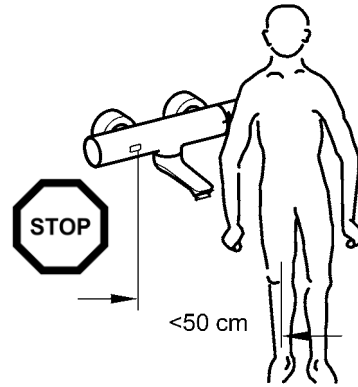
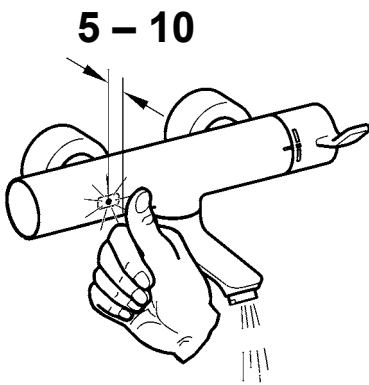

2 **A**  → 38 °C

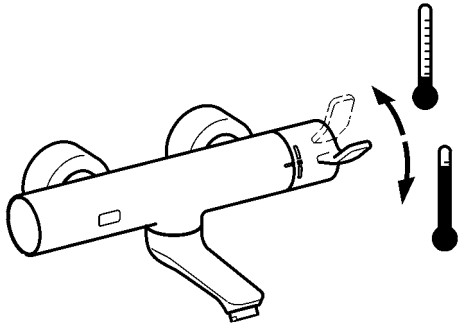

B  → > 38 °C

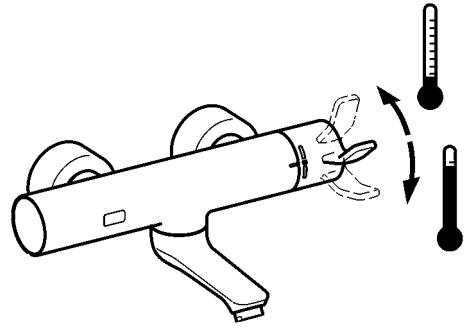

12.

3

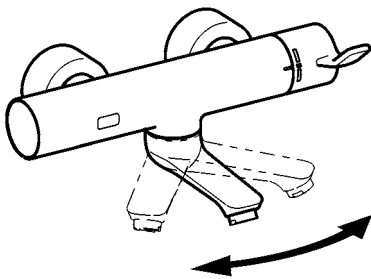

3. Hygienspülung ein- / ausschalten

EN Switching hygiene flushing on/off	NL Hygiënische spoeling in-/uitschakelen	CS Zapněte/vypněte hygienické propláchnutí
FR Activer/désactiver le rinçage hygiénique	PL Włączyć/wyłączyć splukiwanie higieniczne	FI Hygieniahuuhdelun päälle-/ pois päältä kytkeminen
ES Activar/Desactivar el aclarado higiénico	SV Koppla hygienspolningen till / från	RU Гигиеническое промывание включить/выключить
IT Attivare/disattivare lo sciacquo igienico		

- EN**
- ▶ Ensure open outlet.
 - ▶ After 24h of non-use, water flows 30 s
- DE**
- ▶ Freien Auslauf gewährleisten.
 - ▶ Nach 24 h Nichtbenutzung fließt 30 s Wasser.
- FR**
- ▶ Garantir un écoulement libre.
 - ▶ L'eau s'écoule pendant 30 s. après 24 h de non utilisation.
- ES**
- ▶ Garantizar una salida libre.
 - ▶ Si no se realiza ningún uso durante 24 horas, fluye agua durante 30 segundos.
- IT**
- ▶ Garantire l'erogazione libera.
 - ▶ Dopo 24h di inutilizzo scorre acqua per 30 s.
- NL**
- ▶ Vrije uitloop garanderen.
 - ▶ Na 24 uur niet te zijn gebruikt stroomt er gedurende 30 s. water.
- PL**
- ▶ Zapewnić swobodny wylot.
 - ▶ Po 24 godz. niekorzystania przez 30 s. wypływa woda.
- SV**
- ▶ Garantera fritt avlopp.
 - ▶ Vatten flyter 30 s efter 24 timmars användningspaus.
- CS**
- ▶ Zajistěte volný odtok.
 - ▶ Při nepoužívání 24 h nechte 30 s téct vodu.
- FI**
- ▶ Vapaan virtauksen takaaminen.
 - ▶ Käyttämättömänä 24 h jälkeen virtaa vettä 30 s.
- RU**
- ▶ Обеспечить беспрепятственный слив
 - ▶ После того, как устройство не используется в течение 24 ч, в течение 30 сек течёт вода.

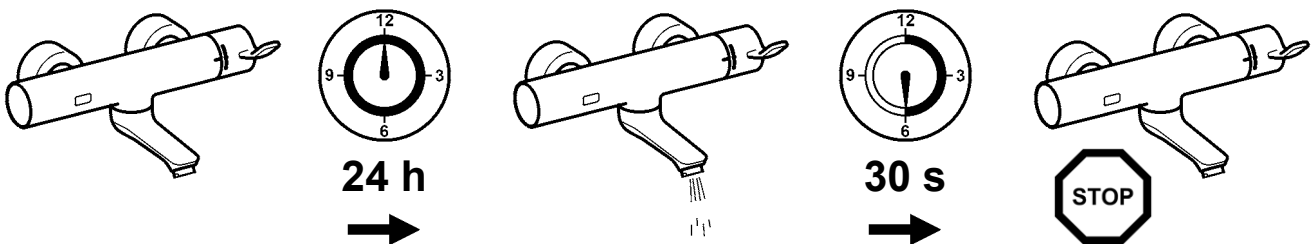

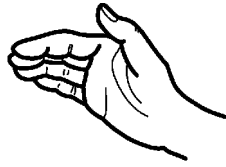
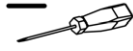

1 - 6

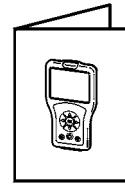
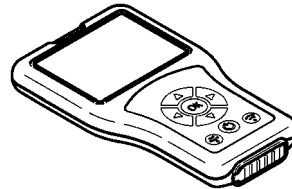
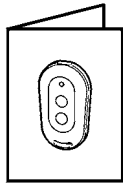
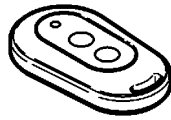

1

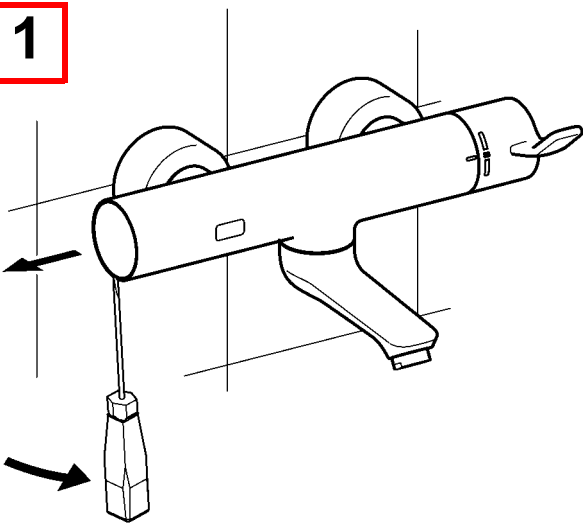

2

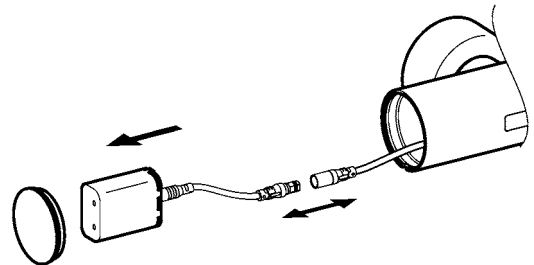

3

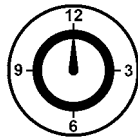

60 s

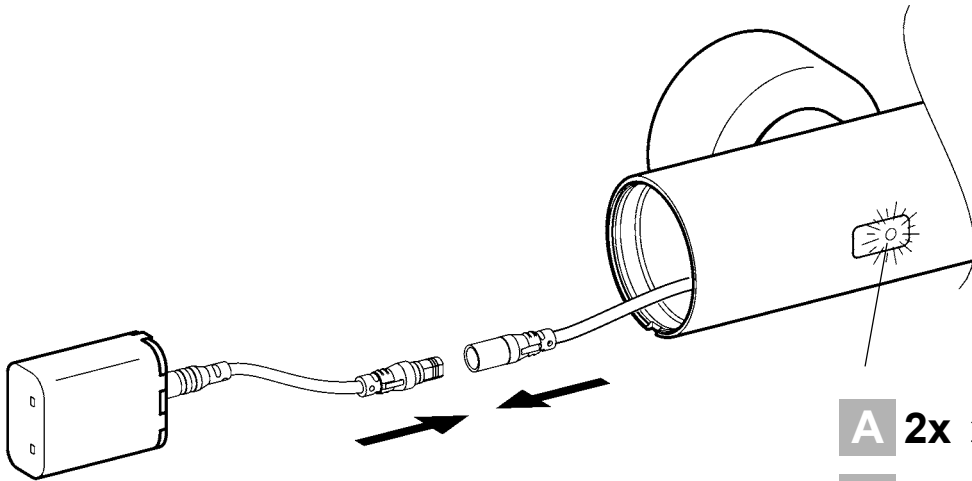

A 2x    

B 1x    

A

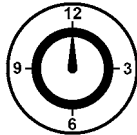
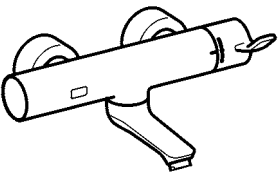

24 h

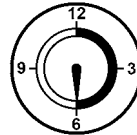
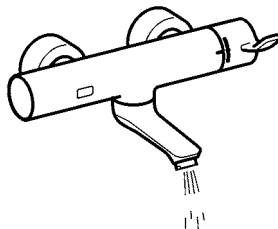

30 s

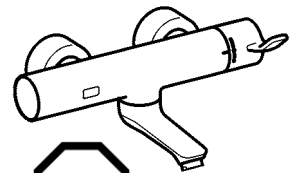

B

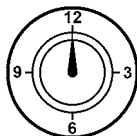
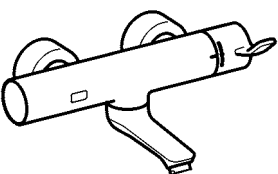

0 h

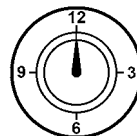
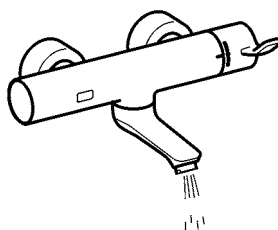

0 s

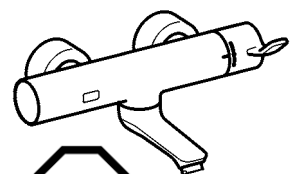

4

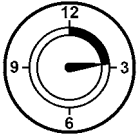

>12 s

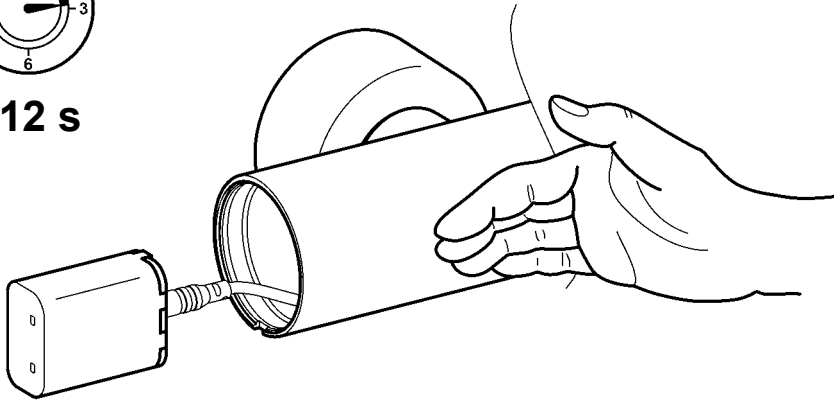

5

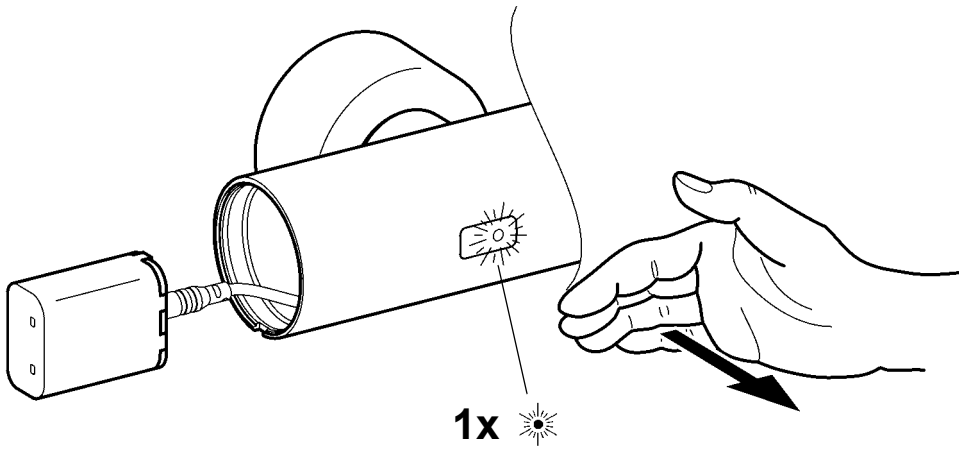

6

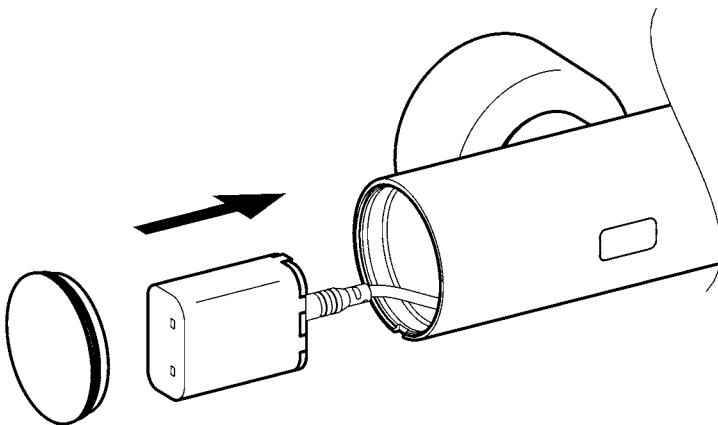

4. Thermische Desinfektion

EN Thermal disinfection
FR Désinfection thermique
ES Desinfección térmica
IT Disinfezione termica

NL Thermische desinfectie
PL Dezynfekcja termiczna
SV Termisk desinfektion

CS Tepelná dezinfekce
FI Terminen desinfiointi
RU Термическая дезинфекция

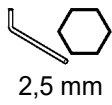

2,5 mm

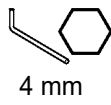

4 mm

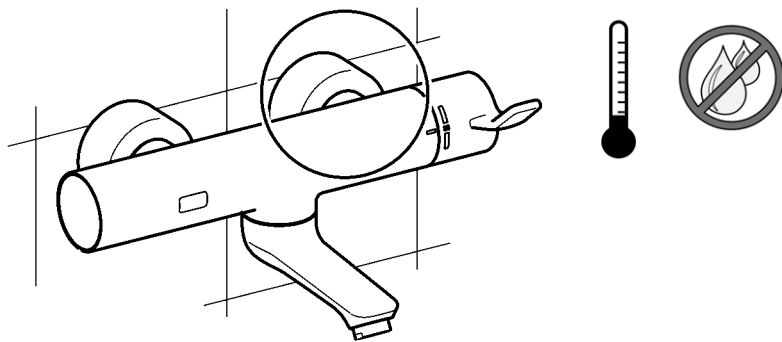

1

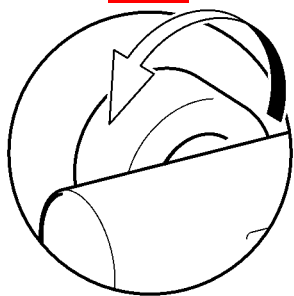

2

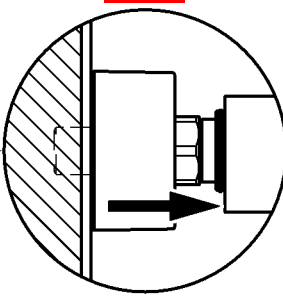

3

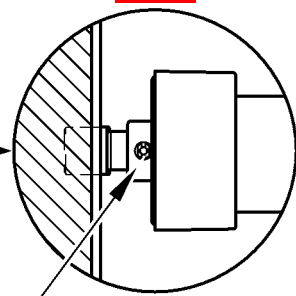

4

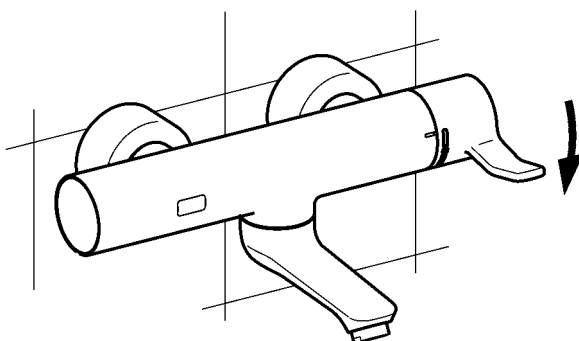

5

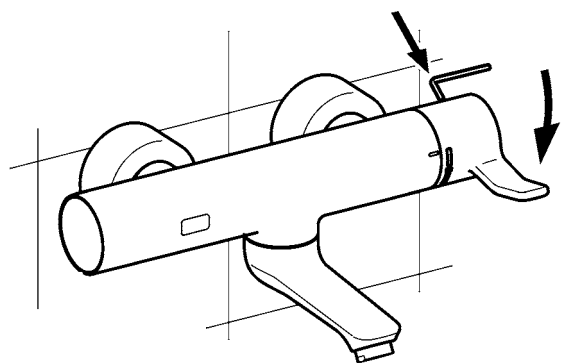

6

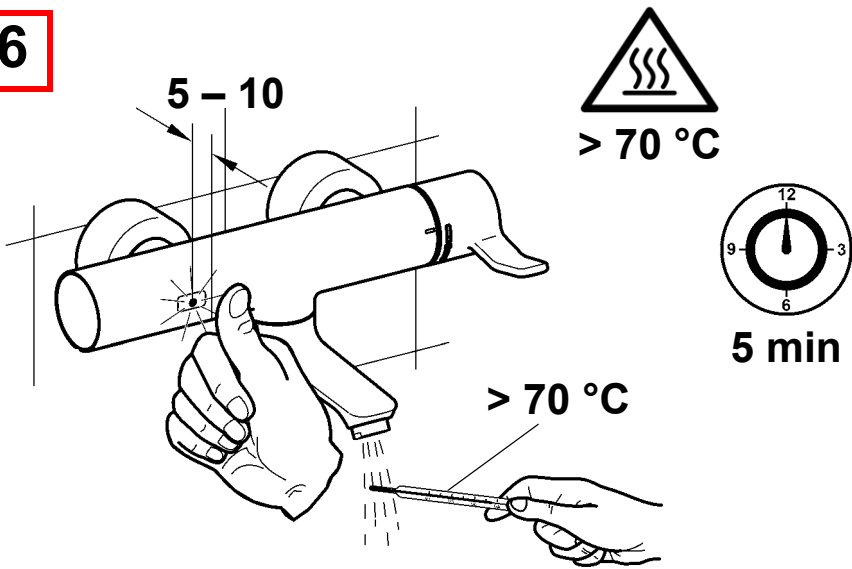

7

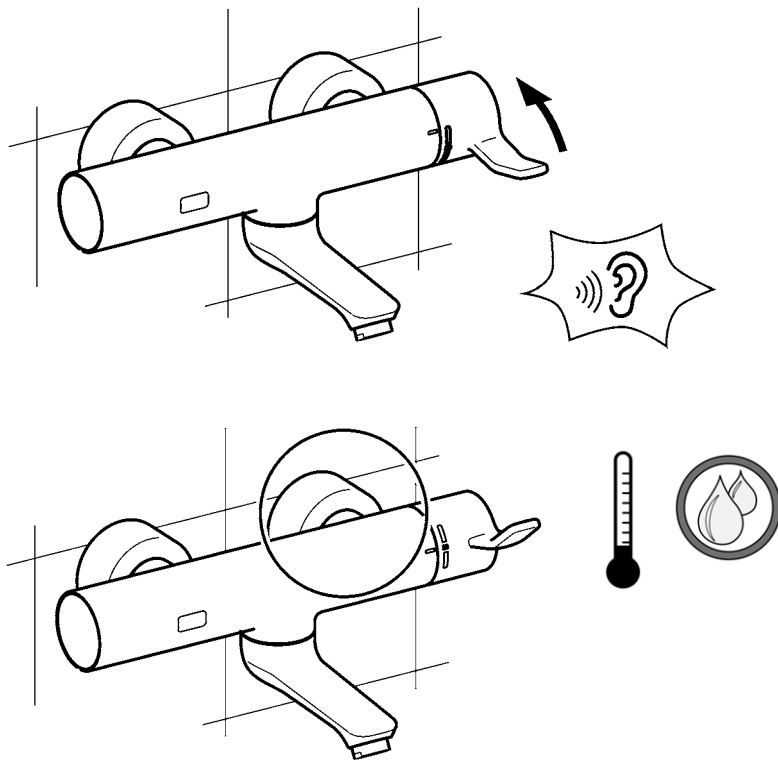

8

9

10

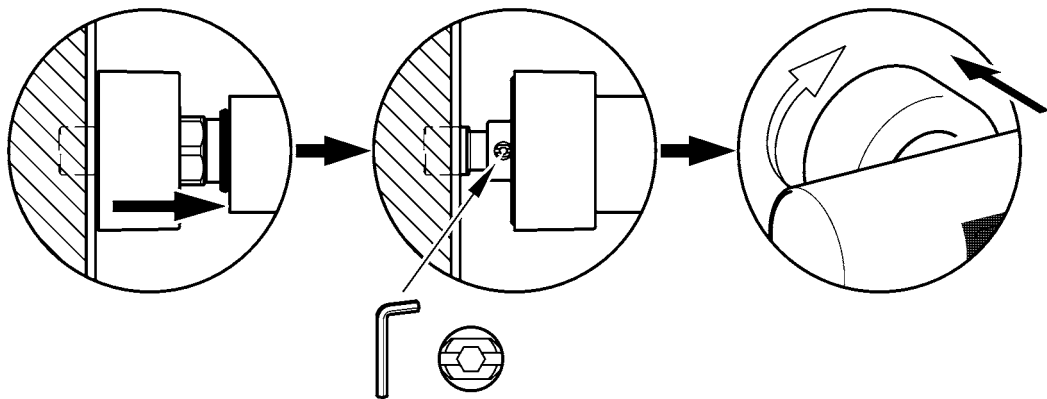

11

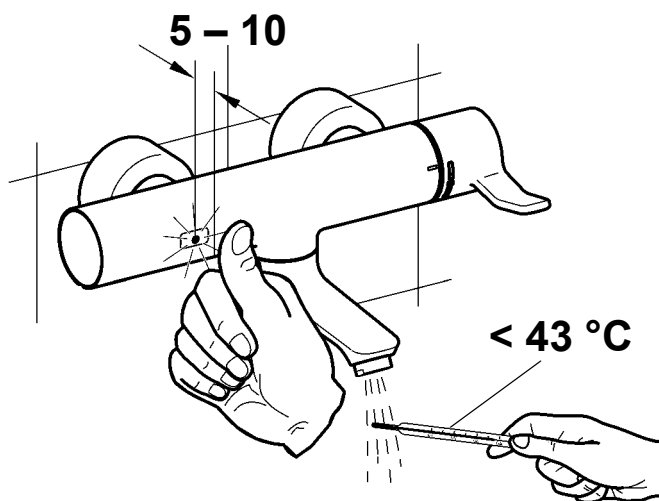

5. Armatur ausschalten

EN Switch off the valve

NL Armatuur uitschakelen

CS Vypnout armaturu

FR Désactiver la robinetterie de

PL Wyłączenie baterii

FI Hanan kytkeminen pois päältä

ES Desconectar la grifería

SV Avstängning av armatur

RU Выключение смесителя

IT Disattivazione della rubinetteria

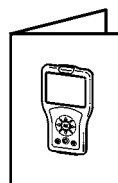
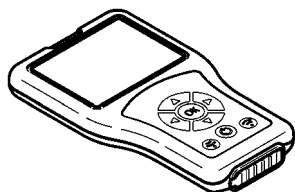

6. Dauerlauf starten

EN Start continual flow

FR Démarrer la marche continue

ES Iniciar el enjuague continuo

IT Avviare l'erogazione continua

NL Continue stroming starten

PL Uruchomić stały wypływ wody

SV Starta kontinuerlig drift

CS Spustit trvalý provoz

FI Tuotantokäytön aloittaminen

RU запустить ресурс

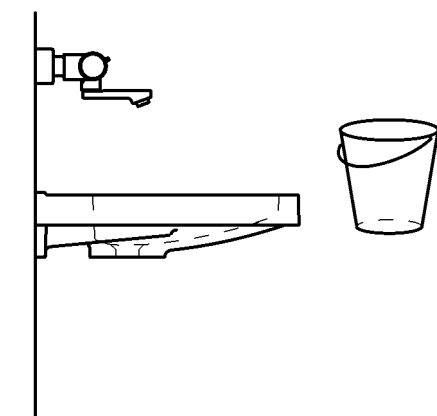
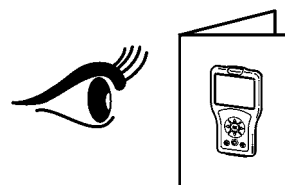
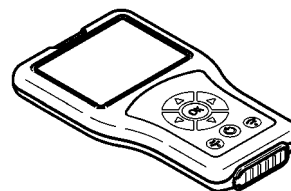
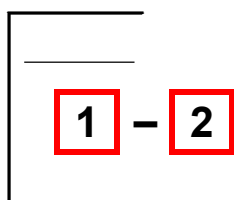
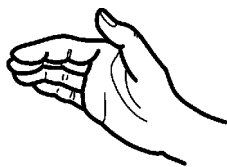
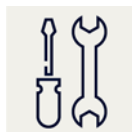

12.

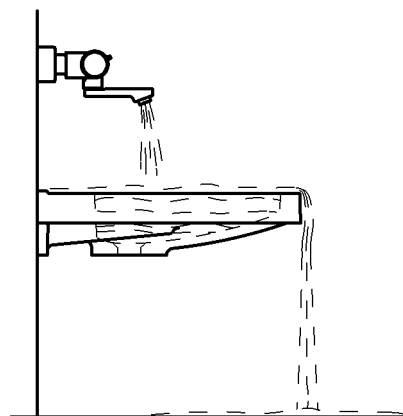

1

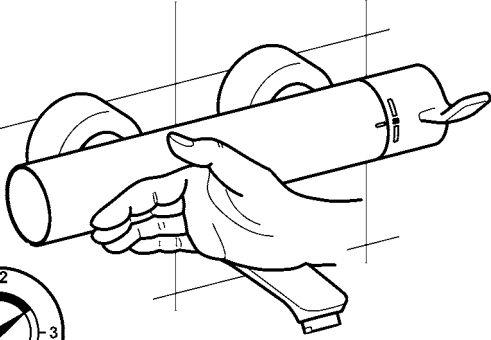

5 – 8 s

2

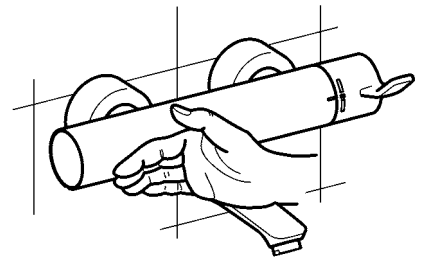
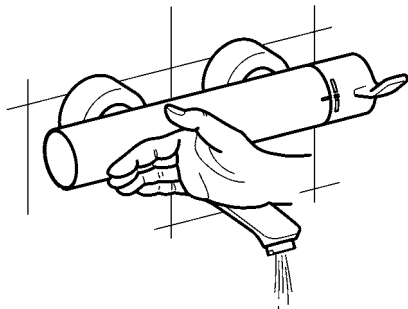
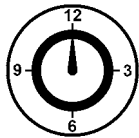
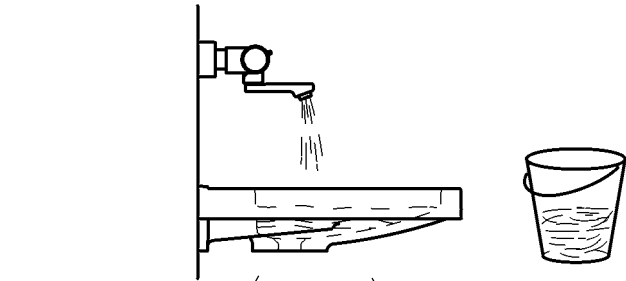
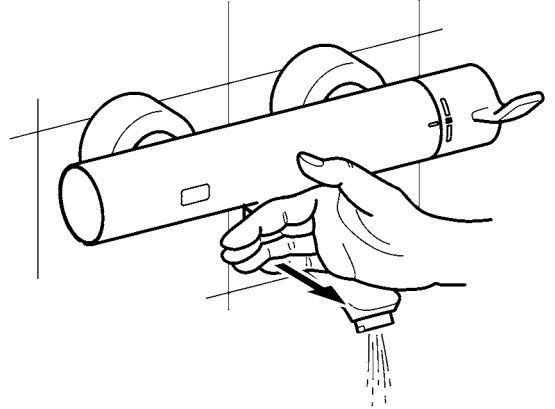

7. Reinigungsabschaltung einschalten

EN Switch on cleaning switch-off	NL Inschakelen van de reiniging shutdown	CS Vypínač pro čištění
FR Activer l'arrêt de nettoyage	PL Włączanie wyłączenia na czas czyszczenia	FI Aktivoida pesuseisokkien
ES Activar el apagado de limpieza	SV Aktivera rengörings avstängning	RU активировать чистка завершение работы
IT Attivare dello spegnimento per pulizia		

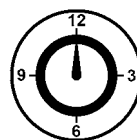
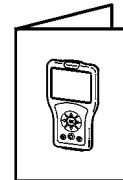
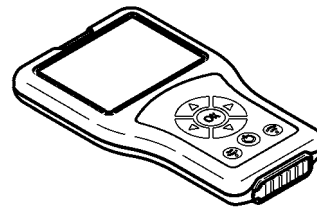
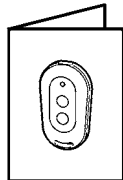

1 min

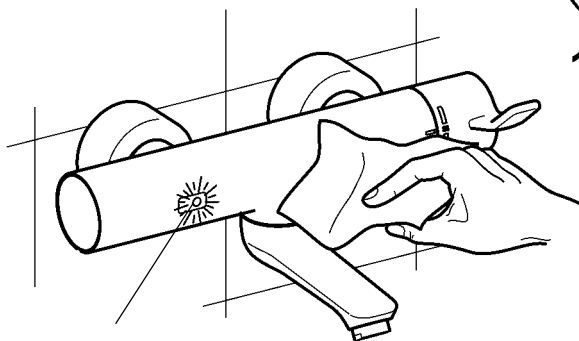

☀ 10s ☀ 10s ☀ ...

8. Fließzeit einstellen

EN Adjust flow duration

NL Stromingstijd instellen

CS Nastavit dobu průtoku

FR Régler la durée d'écoulement

PL Ustawić czas przepływu

FI Aseta virtausaika

ES Ajustar el tiempo de flujo

SV Ställa in flytförmågan

RU Регулировка времени истечения

IT Impostazione della durata di flusso

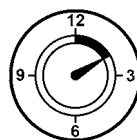
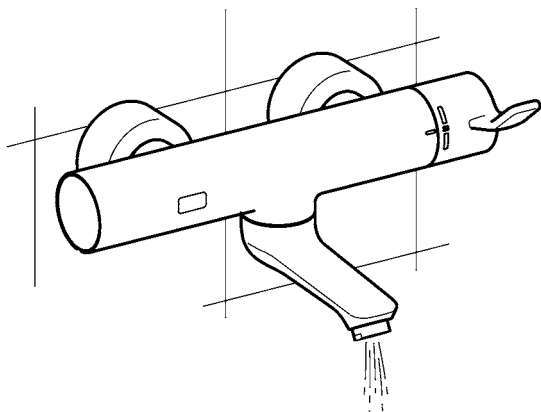

10 s

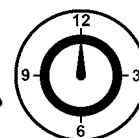
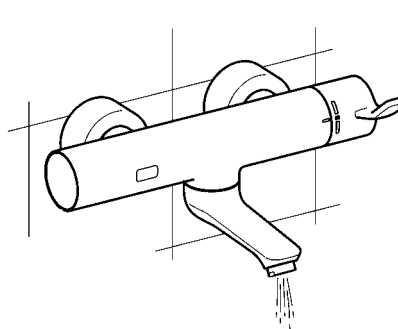
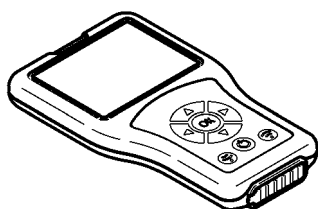

1 – 255 s

9. Hygienespülung einstellen

EN Setting the hygiene flush	NL Instellen van de hygiënespoeling	CS Nastavení hygienického proplachování
FR Réglage de la rinçage d'hygiène	PL Ustawianie spłukiwania higienicznego	FI Hygieniahuuhtelun säätäminen
ES Ajuste del higiene enjuague	SV Ställa in hygienspolning	RU установив гигиена смыва
IT Impostare lo igiene risciacquo		

EN

- ▶ C: Interval adjustable in h
- ▶ D: Flow duration adjustable in s

DE

- ▶ C: Intervall einstellbar in h
- ▶ D: Fließzeit einstellbar in s

FR

- ▶ C: intervalle réglable en h
- ▶ D: durée d'écoulement réglable en s

ES

- ▶ C: Intervalo ajustable en horas
- ▶ D: Tiempo de flujo activable en seg

IT

- ▶ C: intervallo impostabile in h
- ▶ D: durata di flusso impostabile in s

NL

- ▶ C: Interval instelbaar in u
- ▶ D: Stromingstijd instelbaar in s

PL

- ▶ C: odstęp czasu regulowany w godzinach
- ▶ D: czas przepływu regulowany w sekundach

SV

- ▶ C: Intervall kan ställas in i timmar
- ▶ D: Flödestid kan ställas in i sekunder

CS

- ▶ C: Interval s nastavením v h
- ▶ D: Doba průtoku s nastavením v s

FI

- ▶ C: Aikaväli, asetettavissa h
- ▶ D: Virtausaika, asetettavissa s

RU

- ▶ C: интервал задается в ч
- ▶ D: время течения задается в сек

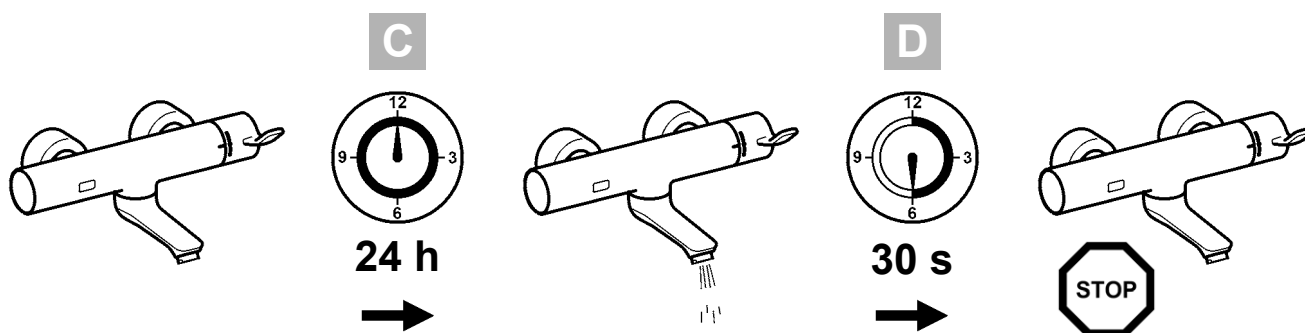

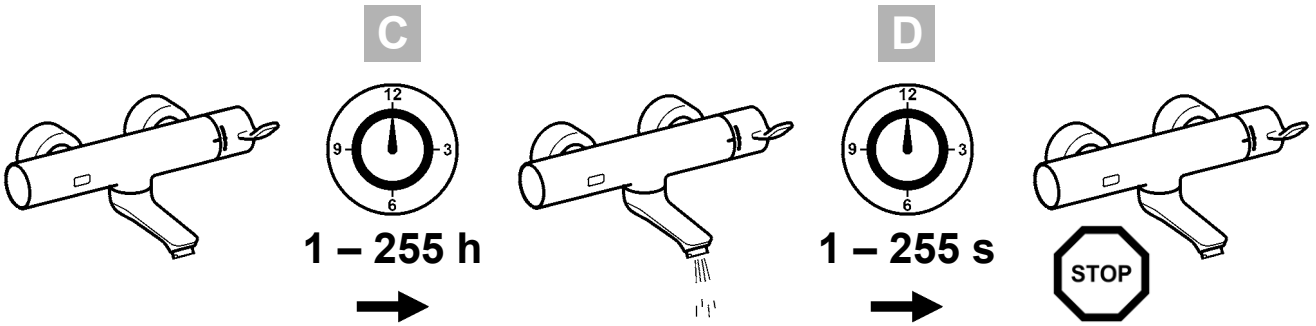
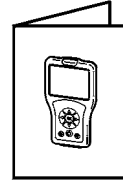
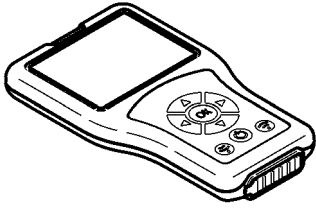

10. Dauerlauf einstellen

EN Setting continuous operating mode

NL Continue stroming instellen

CS Nastavení pomalejšího toku

FR Réglage du fonctionnement en continu

PL Ustawienie ciągłego wypływu

FI Tuotantokäytön säätäminen

ES Ajuste del funcionamiento ininterrumpido

SV Ställa in permanent flöde

RU Настройка непрерывного режима

IT Impostazione del flusso continuo

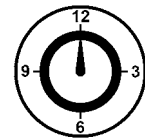
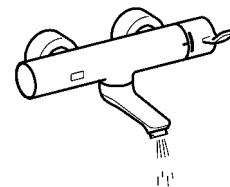
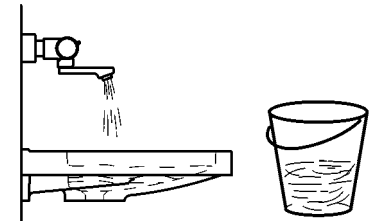
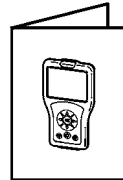
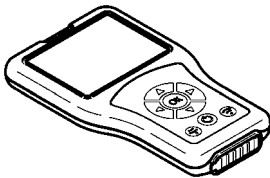
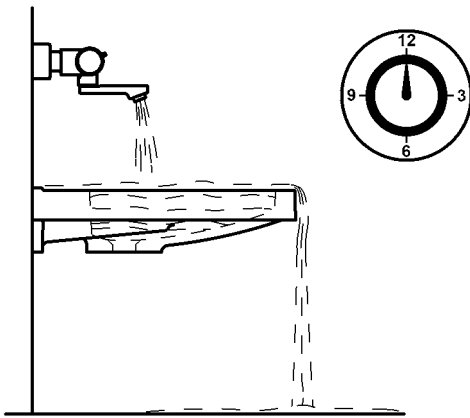
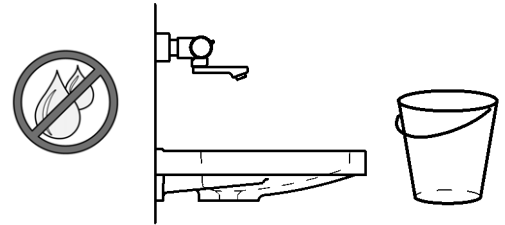

60 s

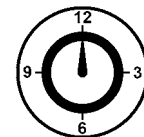
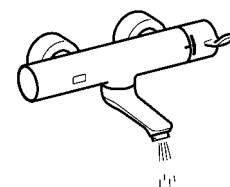
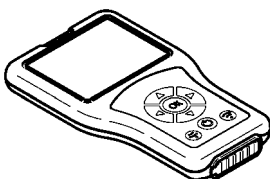

1 – 255 s

11. Reinigungsabschaltung einstellen

EN Set the range
FR Régler le rayon d'action
ES Regular el alcance
IT Impostare la portata

NL Actieradius instellen
PL Ustawienie zasięgu
SV Ställa in räckvidden

CS Nastavení dosahu
FI Aseta ulottuma
RU установить диапазон значений

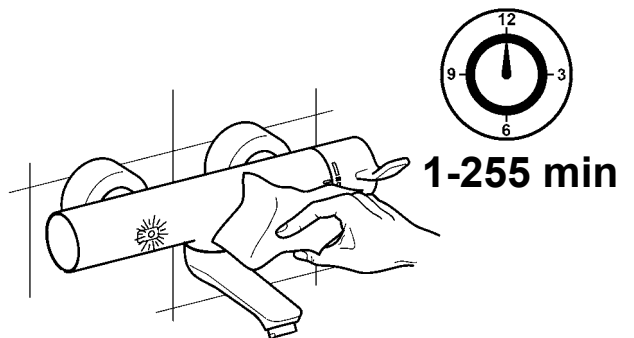
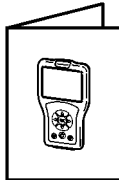
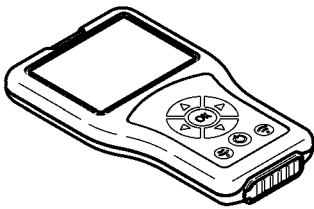
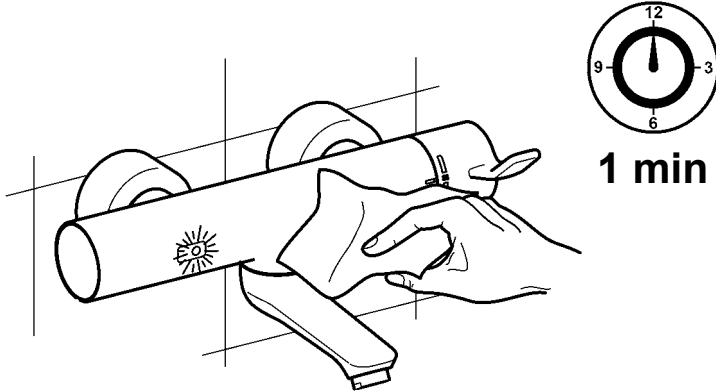

12. Verbrühungsschutz einstellen

EN Adjust scald protection	NL Bescherming tegen verbranding instellen	CS Nastavte ochranu proti opaření
FR Réglage du dispositif de protection contre les échaudures	PL Ustawianie zabezpieczenia przed poparzeniem	FI Palovammasuojan asettaminen
ES Ajustar la protección contra escaldaduras	SV Inställning av skållningsskydd	RU Настройка защиты от ошпаривания
IT Impostare la protezione antiscottatura		



EN

Warning

If the hot-water supply temperature is greater than 43 °C, set the scald-protector.

Failure to observe can cause bodily harm due to scalding.

DE

Warnung

Wenn die Temperatur der Warmwasserversorgung mehr als 43 °C beträgt, den Verbrühungsschutz einstellen.

Nichtbeachtung kann Körperverletzung durch Verbrühung bewirken.

FR

Avertissement

Si la température de l'alimentation eau chaude dépasse 43 °C, il convient de régler le dispositif de protection contre les échaudures.

Le non-respect est susceptible de provoquer des blessures corporelles par échaudure.

ES

Aviso

Si la temperatura del suministro de agua caliente es superior a 43 °C, de ajusta la protección contra escaldaduras.

La no observación puede tener como consecuencia escaldaduras.

IT

Avvertenza

Se la temperatura dell'alimentazione acqua calda è superiore a 43 °C, impostare la protezione antiscottatura.

La non osservanza può causare ustioni.

NL

Waarschuwing

Indien de temperatuur van de watervoorziening hoger is dan 43 °C, de bescherming tegen verbranding instellen. Veronachtzaming kan letsel door verbranden veroorzaken.

PL

Ostrzeżenie

Jeśli temperatura wody w instalacji doprowadzającej przekracza 43 °C, należy ustawić zabezpieczenie przed poparzeniem.

Nieprzestrzeganie tego zalecenia może prowadzić do urazów ciała spowodowanych poparzeniem.

SV

Varning

Skållningsskyddet ska ställas in om varmvattnet blir varmare än 43 °C. Inställning av skållningsskydd.

Om detta inte efterföljs finns det risk för skållningsskador.

CS

Varování

Když teplota přiváděné teplé vody činí více než 43 °C, nastavte ochranu proti opaření.

Nerespektování může vést k poranění opařením.

FI

Varoitus

Kun lämminvesisyötön lämpötila on enemmän kuin 43 °C, aseta palovammasuoja.

Huomioon ottamatta jättäminen voi saada aikaan vartalovamman palovammasta.

RU

Предупреждение

Если температура в линии подачи горячей воды больше 43 °C, настройте защиту от ошпаривания.

Вследствие несоблюдения данного указания возможно нанесение вреда здоровью в результате ошпаривания.

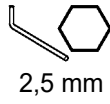
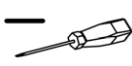

2,5 mm

1

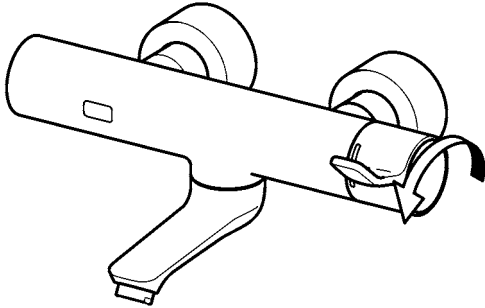

2

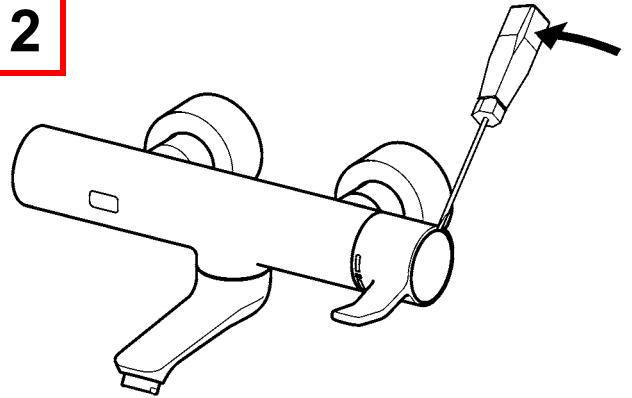

3

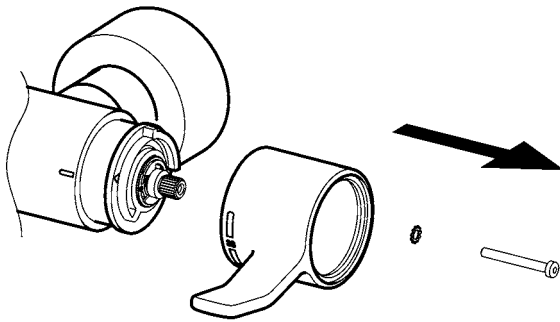

4

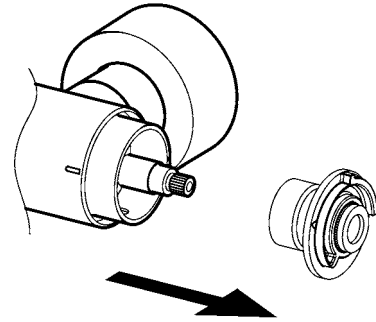

5

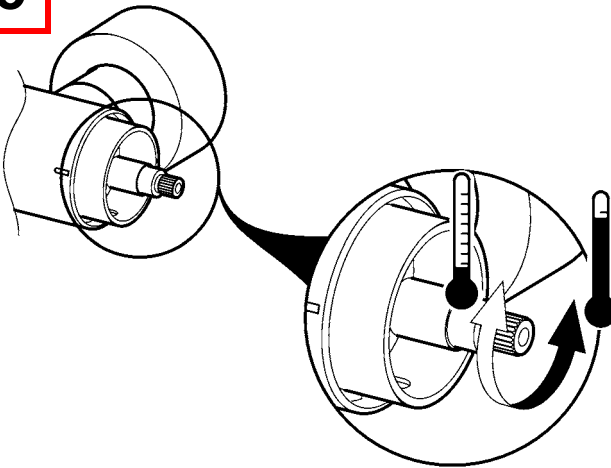

6

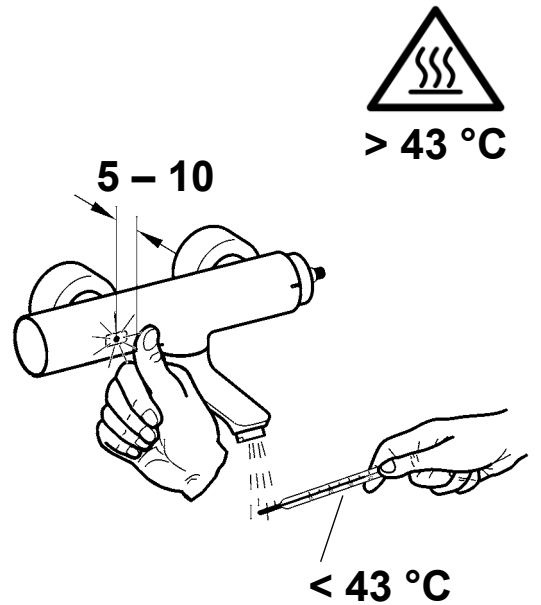

7

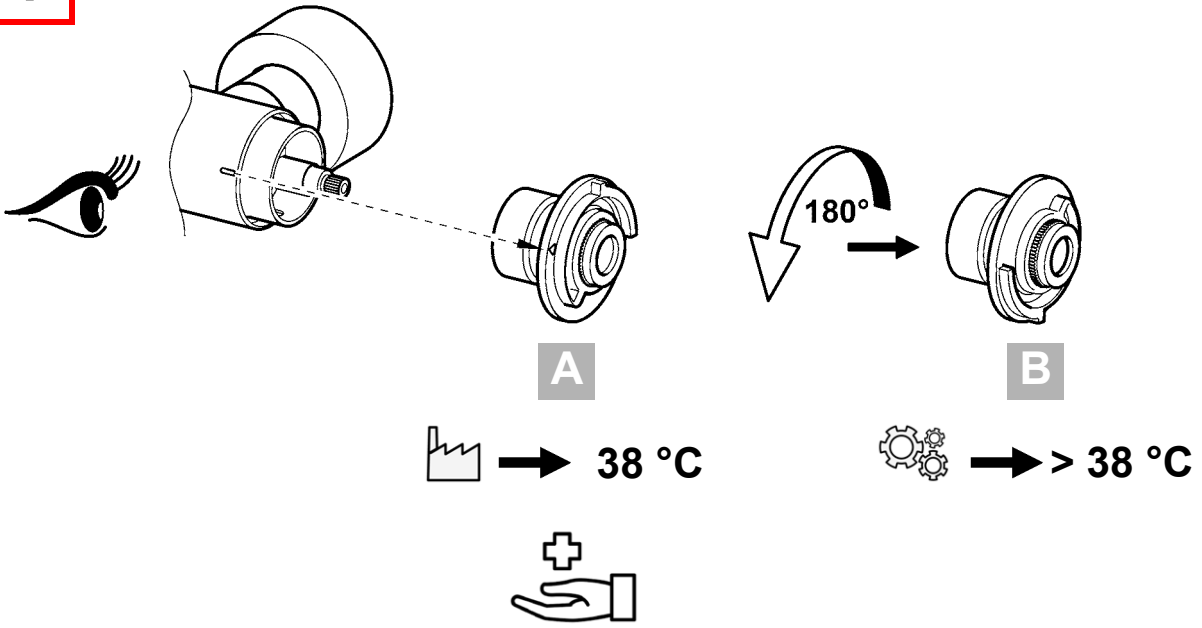

8

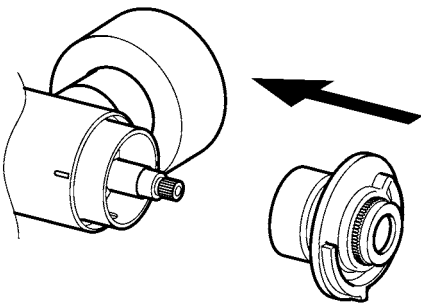

9

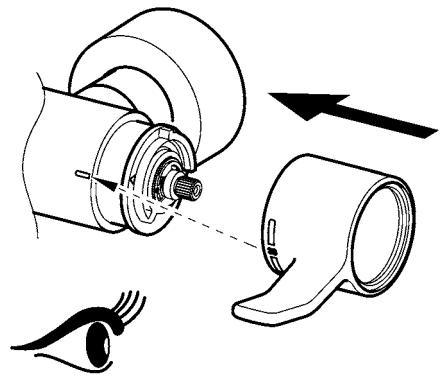

10

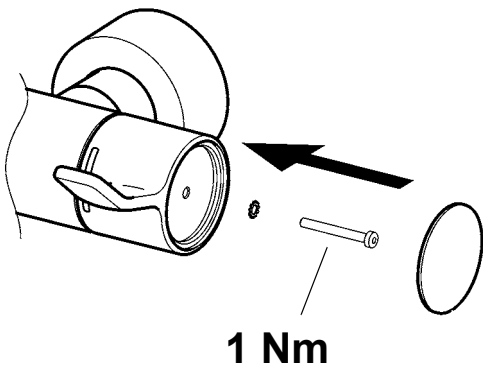

13. Wartung

EN Maintenance
FR Maintenance
ES Mantenimiento
IT Manutenzione

NL Onderhoud
PL Konserwacja
SV Underhåll

CS Varování
FI Huolto
RU Техническое обслуживание





22 mm



16.

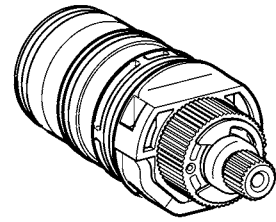

17.



18.

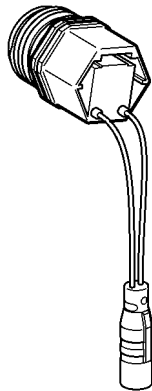

19.

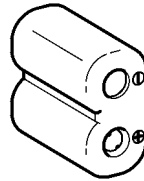

20.

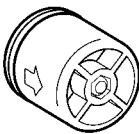

21.

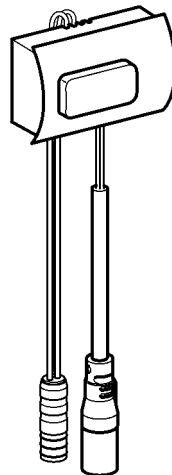

1

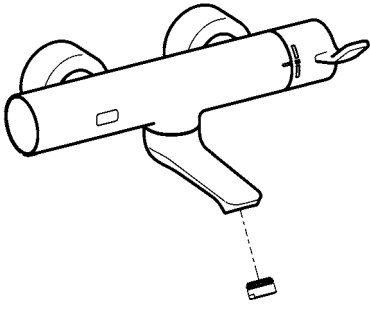

2

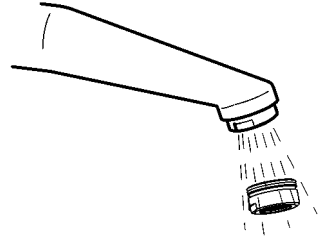

14. Armatur demontieren

EN Remove fitting

FR Démontage de la robinetterie

ES Desmontar la grifería

IT Smontaggio dell'apparecchio

NL Armatuur demonteren

PL Zdemontować armaturę

SV Demontera armaturen

CS Demontáž armatury

FI Hanan irrottaminen

RU Демонтаж арматуры

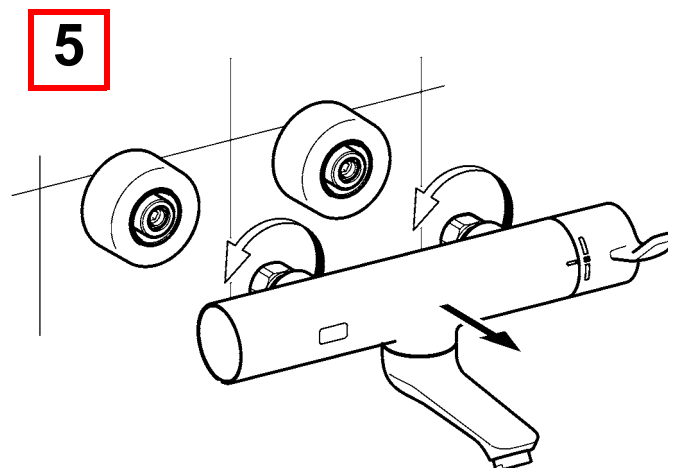
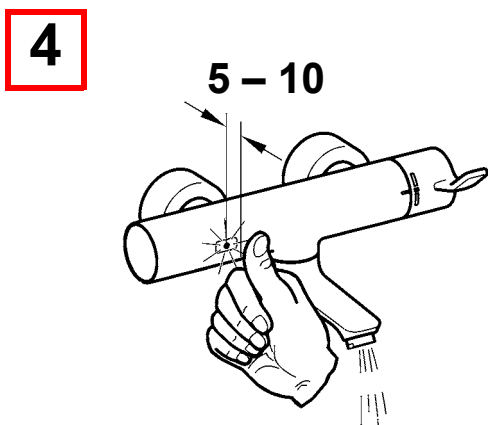
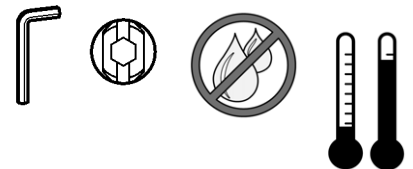
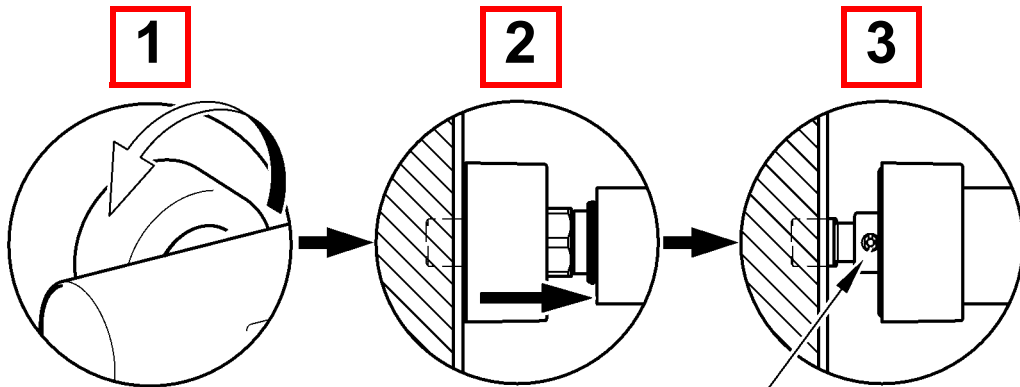
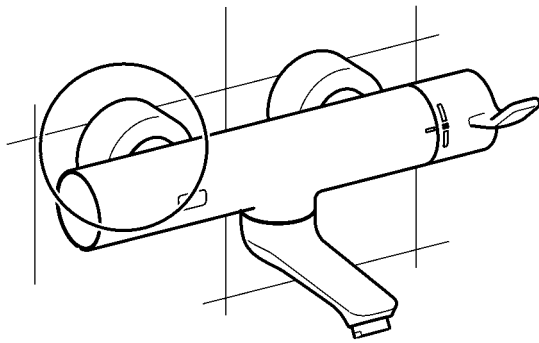
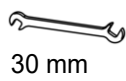
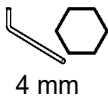

15. Armatur montieren

EN Install fitting

FR Montage de la robinetterie

ES Montar la grifería

IT Montaggio dell'apparecchio

NL Armatuur monteren

PL Zamontować armaturę

SV Montera armaturen

CS Montáž armatury

FI Hanan asentaminen

RU Монтаж арматуры

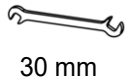
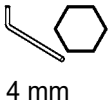

1

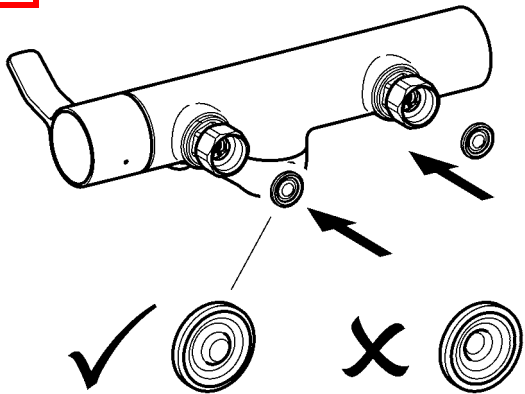

2

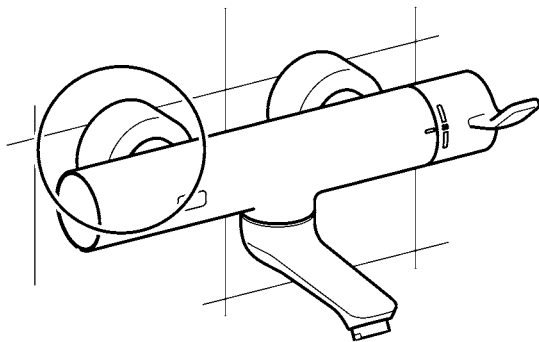
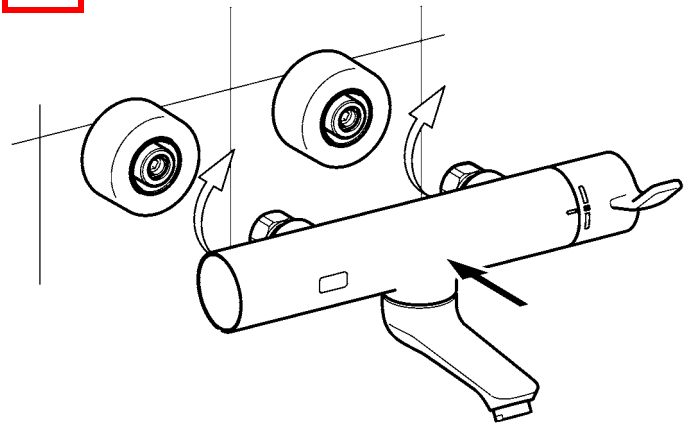

3

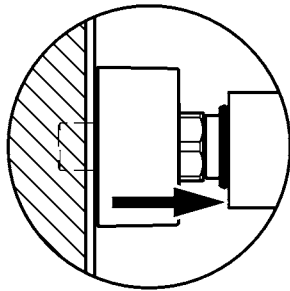

4

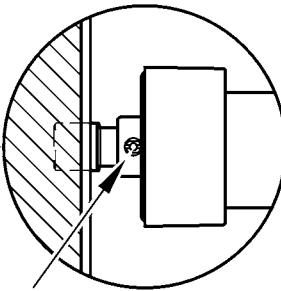

5

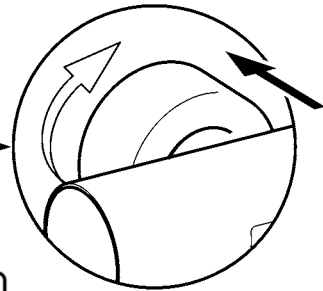

16. Siebe wechseln

EN Replace the filters
FR Remplacement les filtres
ES Cambiar los tamices
IT Sostituire i filtri

NL Zeven vervangen
PL Wymiana sit
SV Byt filter

CS Vyměňte síto
FI Siivilän vaihto
RU Сменить сеточки

1

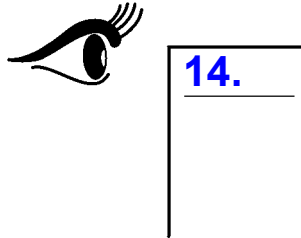

2

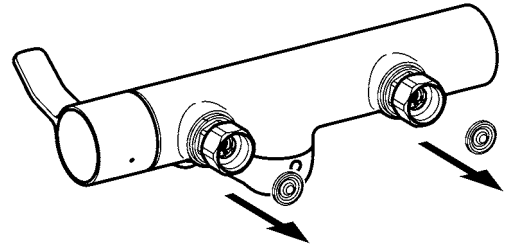

3

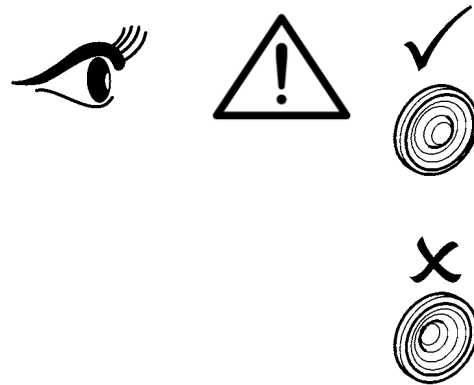
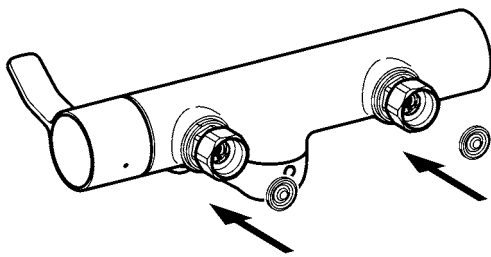

4

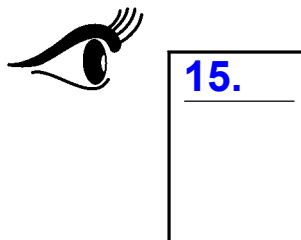

17. Thermostatkartusche wechseln

EN Changing the thermostat cartridge	NL Thermostaatcartridge vervangen	CS Výměna zásobníku termostatu
FR Remplacement de la cartouche du thermostat	PL Wymiana głowicy termostatycznej	FI Termostaattipatruunan vaihtaminen
ES Cambio del cartucho de termostato	SV Byta termostatpatron	RU Замена картриджа термостата
IT Sostituzione della cartuccia termostatica		



EN

Warning

After installing the fitting or removing the thermocouple, adjust the scald protector. Failure to observe can cause bodily harm due to scalding.

DE

Warnung

Nach Montage der Armatur oder Demontage des Thermoelements den Verbrühungsschutz einstellen. Nichtbeachtung kann Körperverletzung durch Verbrühung bewirken.

FR

Avertissement

Après le montage du robinet ou le démontage du thermocouple, régler la protection contre les échaudures. Le non-respect est susceptible de provoquer des blessures corporelles par échaudure.

ES

Aviso

Tras montar la grifería o después de desmontar el termoelemento, ajustar la protección contra escaldaduras. La no observación puede tener como consecuencia escaldaduras.

IT

Avvertenza

Al termine del montaggio della rubinetteria o dopo lo smontaggio del termoelemento, impostare la protezione antiscottatura. La non osservanza può causare ustioni.

NL

Waarschuwing

Na de montage van de armatuur of demontage van het thermische element de bescherming tegen verbranding instellen. Veronachtzaming kan letsel door verbranden veroorzaken.

PL

Ostrzeżenie

Po zamontowaniu baterii lub demontażu termoogniwa należy ustawić zabezpieczenie przed poparzeniem. Nieprzestrzeganie tego zalecenia może prowadzić do urazów ciała spowodowanych poparzeniem.

SV

Varning

Ställ in skållningsskyddet efter montering av armaturen eller demontering av termoelementet. Om detta inte efterföljs finns det risk för skållningsskador.

CS

Varování

Po montáži armatury nebo demontáži termočlátku nastavte ochranu proti opaření. Nerespektování může vést k poranění opařením.

FI

Varoitus

Laitteiston asennuksen tai lämpöelementin purkamisen jälkeen asenna palovammasuoja. Huomioon ottamatta jättäminen voi saada aikaan vartalovamman palovammasta.

RU

Предупреждение

После монтажа арматуры или демонтажа термoelementa настроить защиту от ошпаривания. Вследствие несоблюдения данного указания возможно нанесение вреда здоровью в результате ошпаривания.

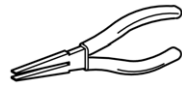
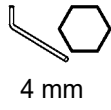
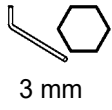
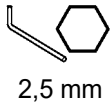

1



14.

1 - 4

2

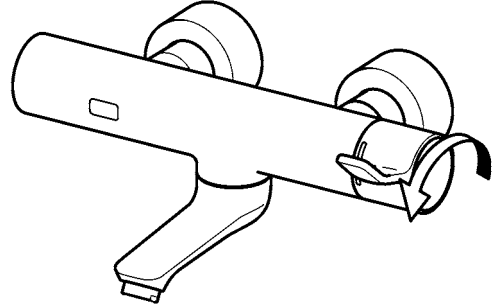

3

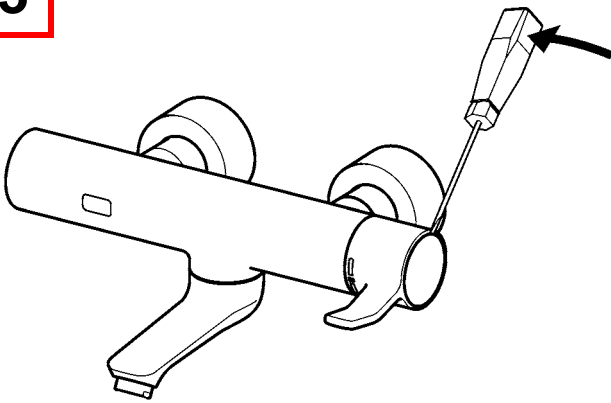

4

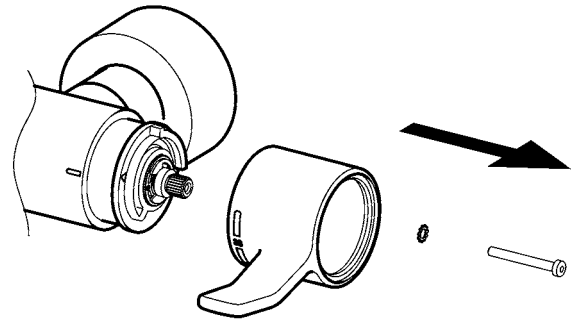

5

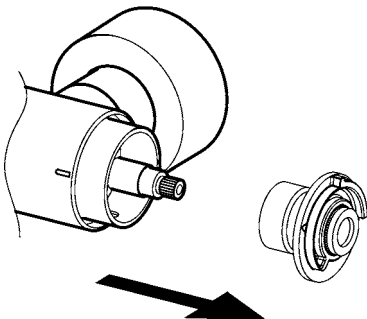

6

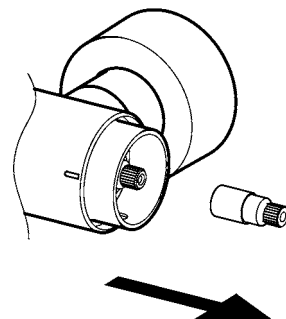

7

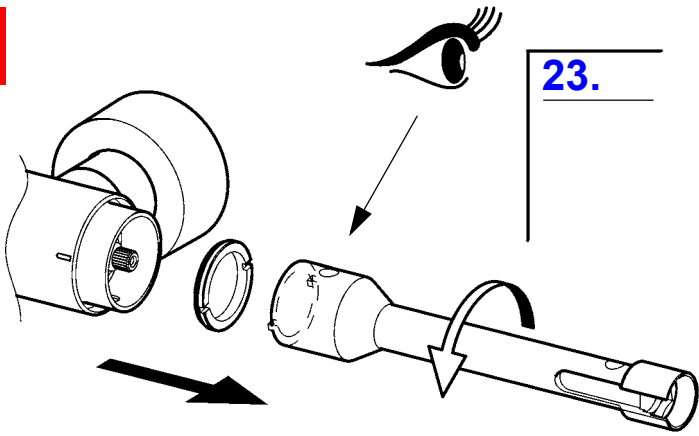

8

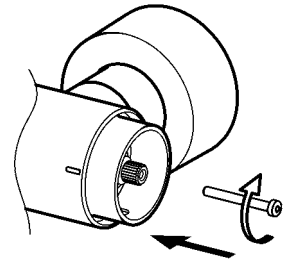

9

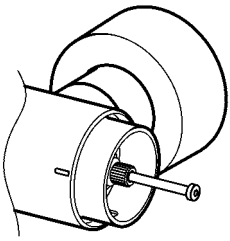

10

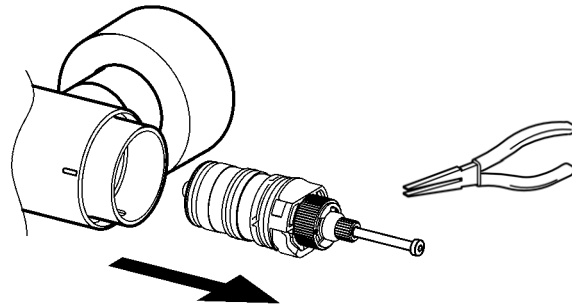

11

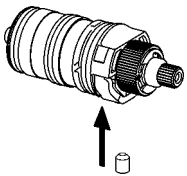

12

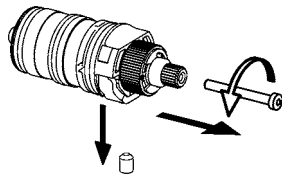

13

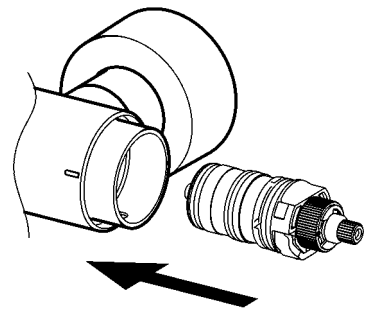

14

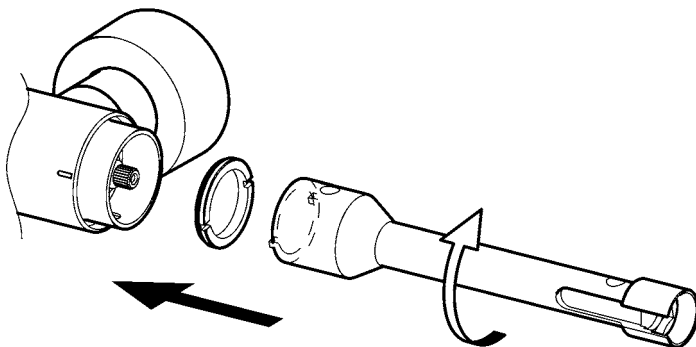

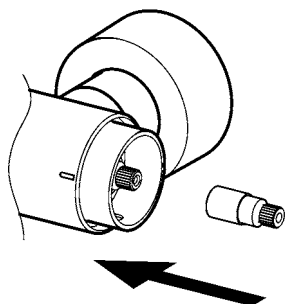
15**16**

> 43 °C

12.

5

10

18. Magnetventilkartusche wechseln

EN Replacing the solenoid valve cartridge

NL Magneetventielpatroon verandering

CS Výměna kartuše s magnetickým ventilem

FR Remplacement de la cartouche d'électrovanne

PL Wymiana wkładu zaworu elektromagnetycznego

FI Magneettiventtiilipanoksen vaihtaminen

ES Cambiar cartucho de la válvula electromagnética

SV Byta magnetventilpatron

RU Замена картриджа

электромагнитного клапана

IT Sostituzione della cartuccia della valvola elettromagnetica

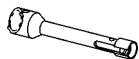
**1**

14.

1

4

2

21.

2

6

3

23.

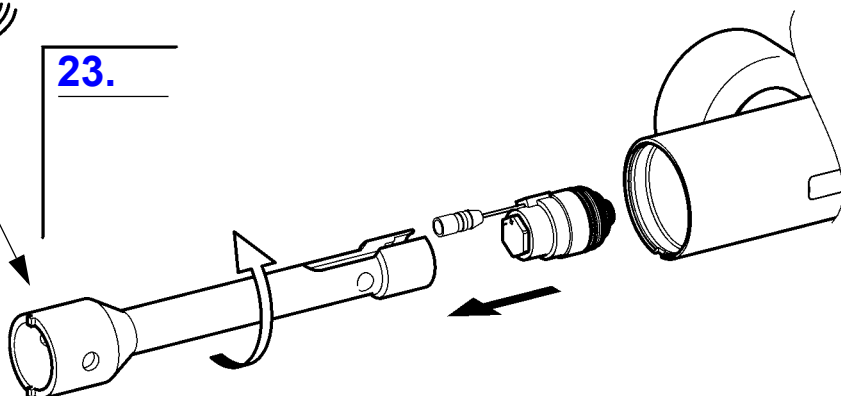

4

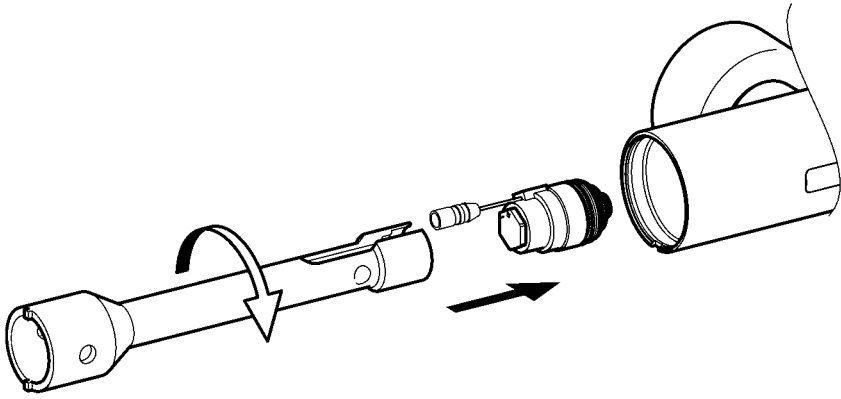

5



21.

7 - **11**

6



15.

3 - **5**

19. Batteriewechsel

EN Battery replacement
 FR Remplacement des piles
 ES Cambio de la pila
 IT Cambio delle batterie

NL Batterijen vervangen
 PL Wymiany baterii
 SV Batteribyte

CS Výměna baterie
 FI Paristonvaihto
 RU замена батареи

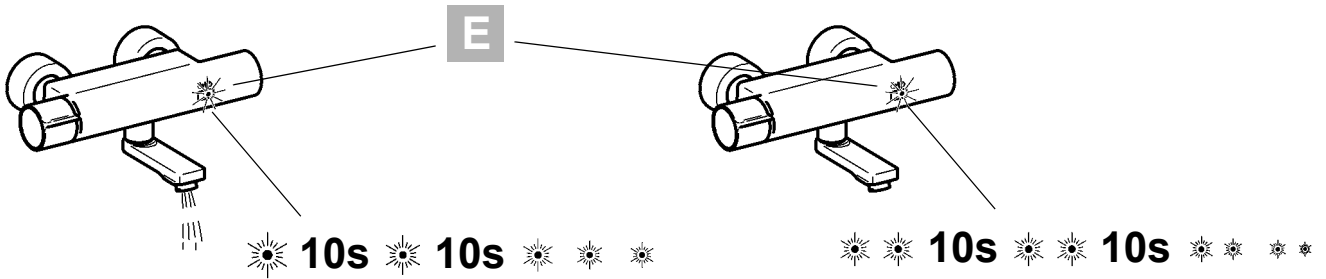

EN E Red

ES E Rojo

PL E Czerwony

FI E Punainen

DE E Rot

IT E Rosso

SV E Röd

RU E красный

FR E Rouge

NL E Rood

CS E Červený

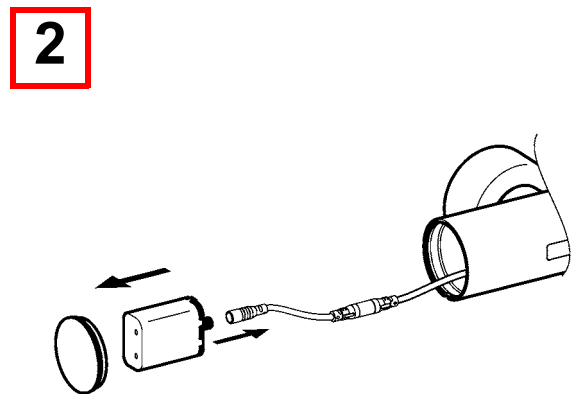
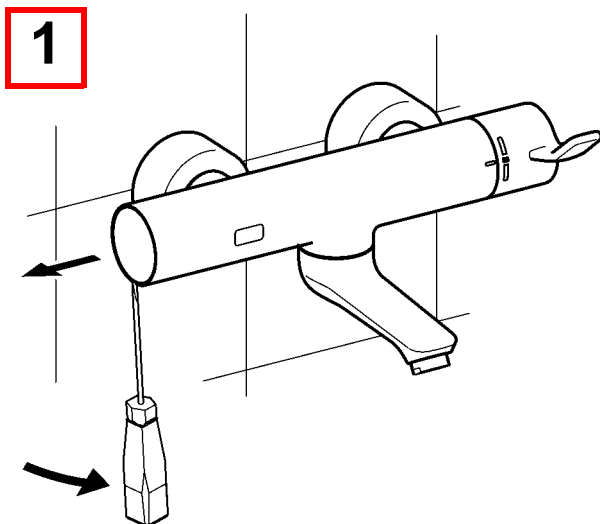
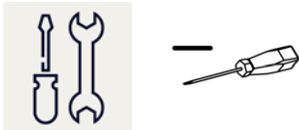

3

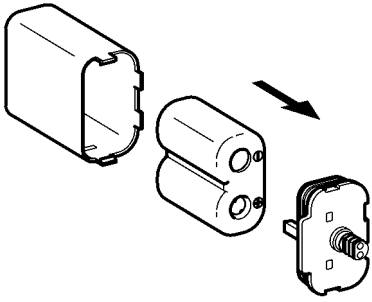

4

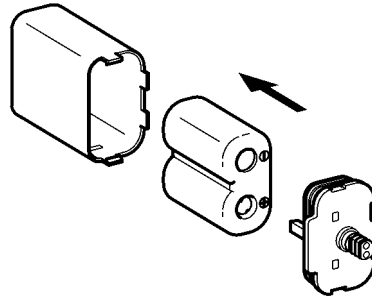

6 V DC

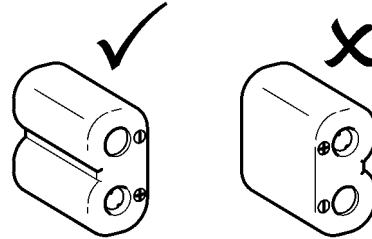

5

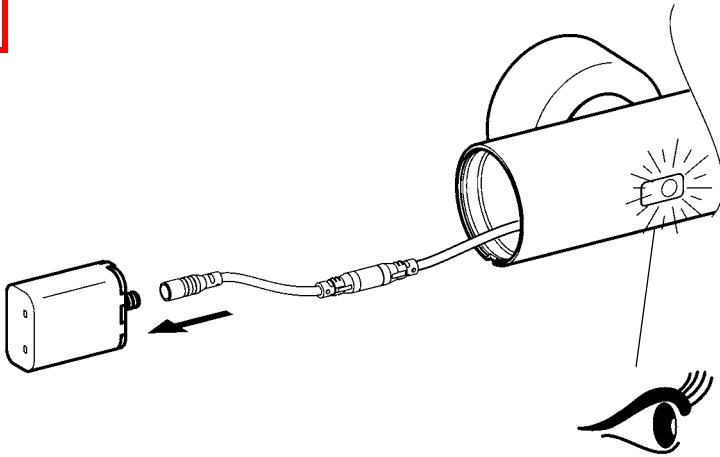

3.

A 2x    

B 1x    

6

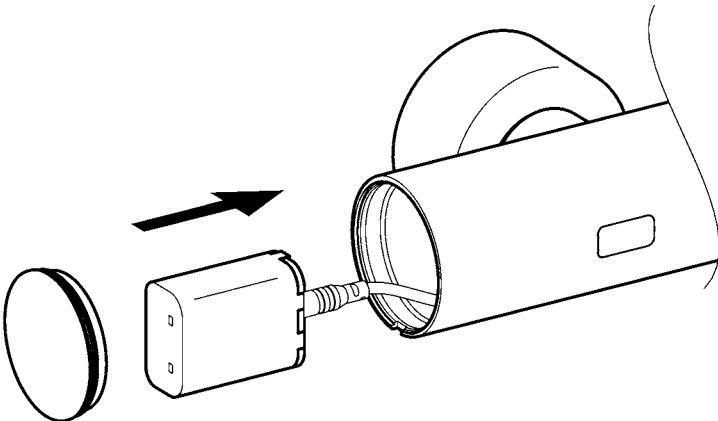

20. Rückflussverhinderer wechseln

EN Replace the return flow inhibitor

NL Terugstroomklep vervangen

CS Vyměňte zábranu zpětného průtoku

FR Remplacement du clapet de non-retour

PL Wymiana zaworu zwrotnego

FI Paluuvirtausestäjän vaihto

ES Reemplazar la válvula antiretorno

SV Byt återströmningsskydd

RU Заменить клапан обратного течения

IT Sostituire la valvola antiriflusso

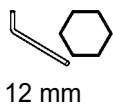

12 mm

1

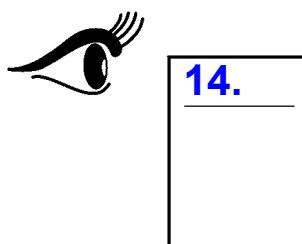

2

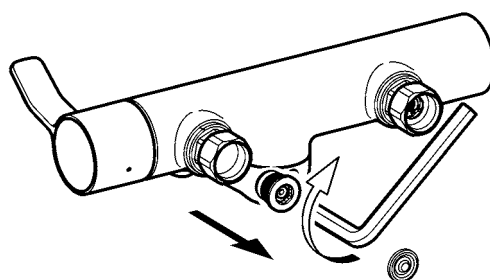

3

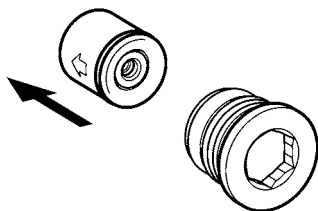

4

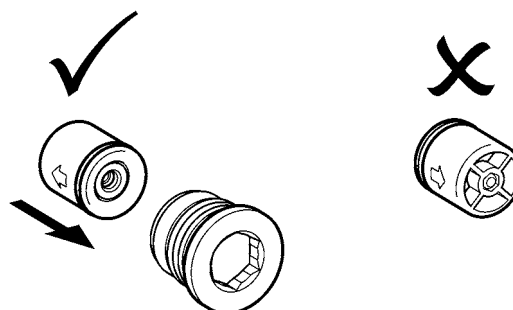

5

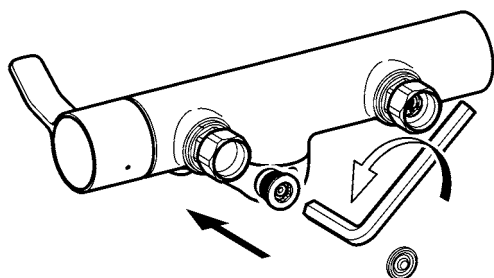

6

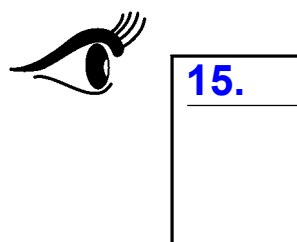

21. Sensor wechseln

EN Replace sensor
FR Changer le capteur
ES Cambiar el sensor
IT Cambiare il sensore

NL Sensor vervangen
PL Wymienić czujnik
SV Byt sensor

CS Vyměňte snímač
FI Anturi vaihto
RU Замена Датчик

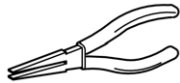

1



14.

1 - **4**

2

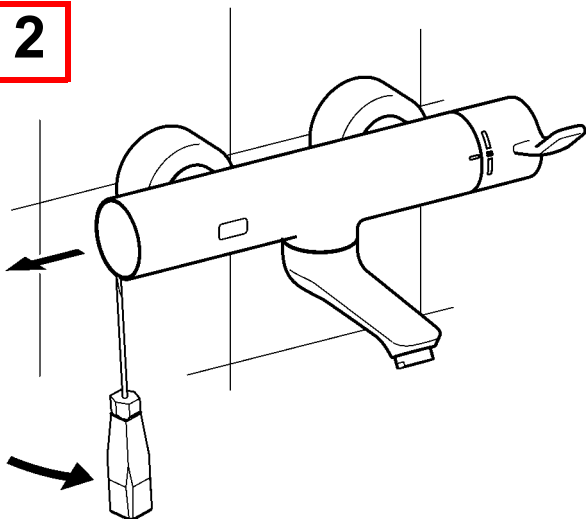

3

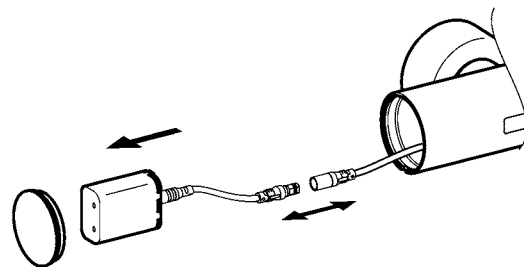

4

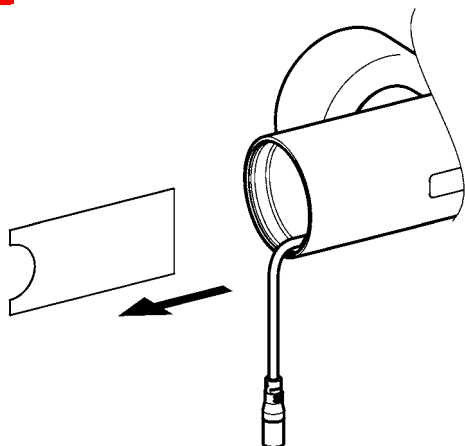

5

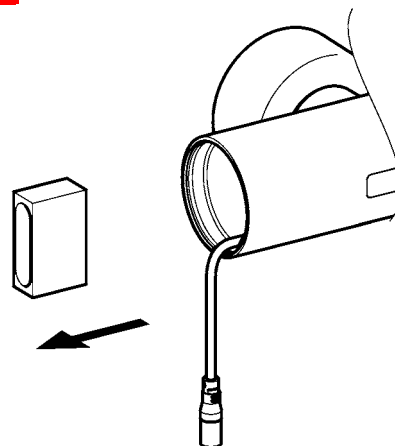

6

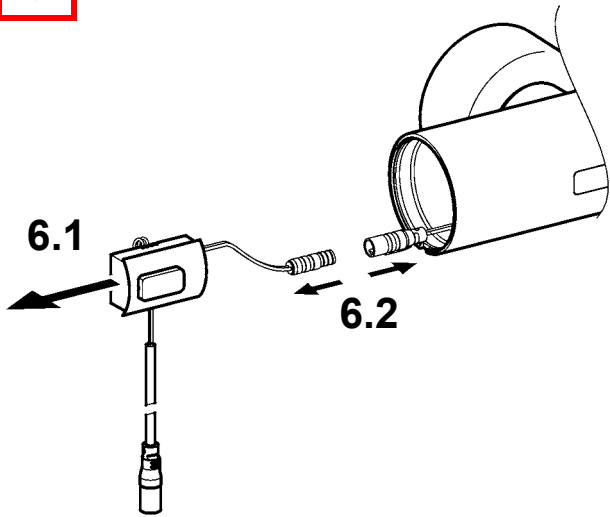

7

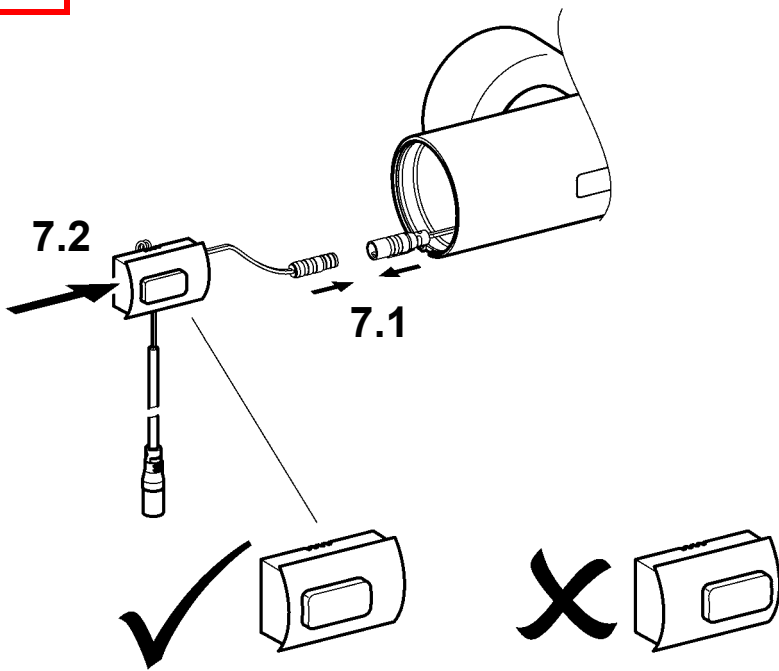

8

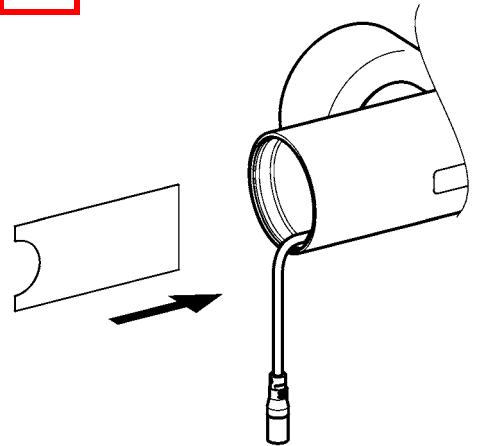



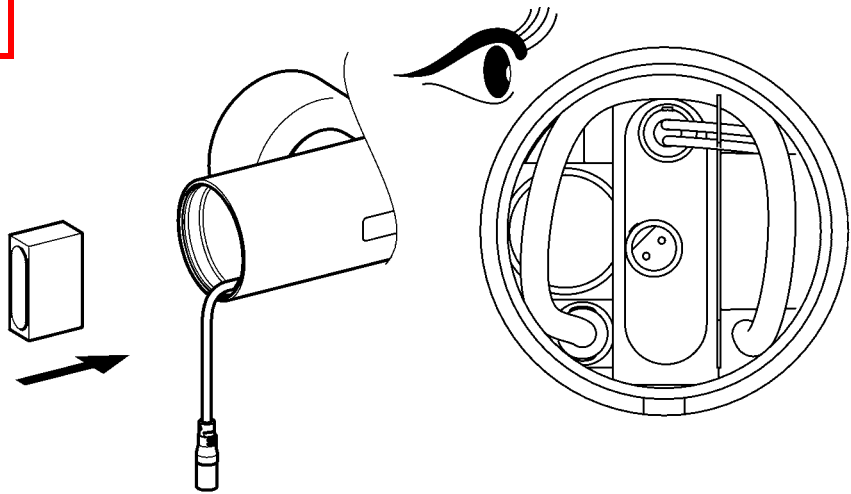



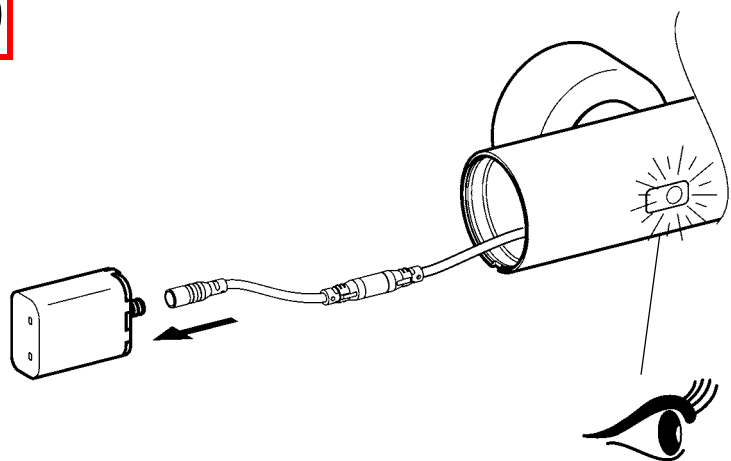

9



10



- 3.
- A 2x    
 - B 1x    

11

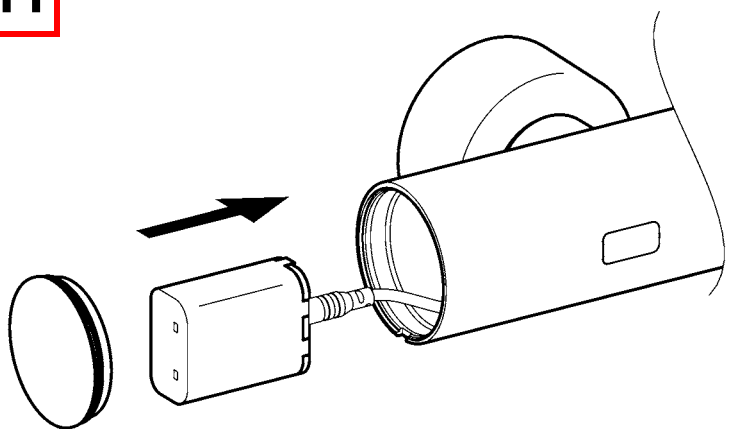

12

- 15.
- 2** - **5**

22. Ersatzteile

EN Replacement parts
FR Pièces de rechange
ES Piezas de recambio
IT Pezzi di ricambio

NL Reserveonderdelen
PL Części zamienne
SV Reservdelar

CS Náhradní díly
FI Varaosat
RU Запчасти

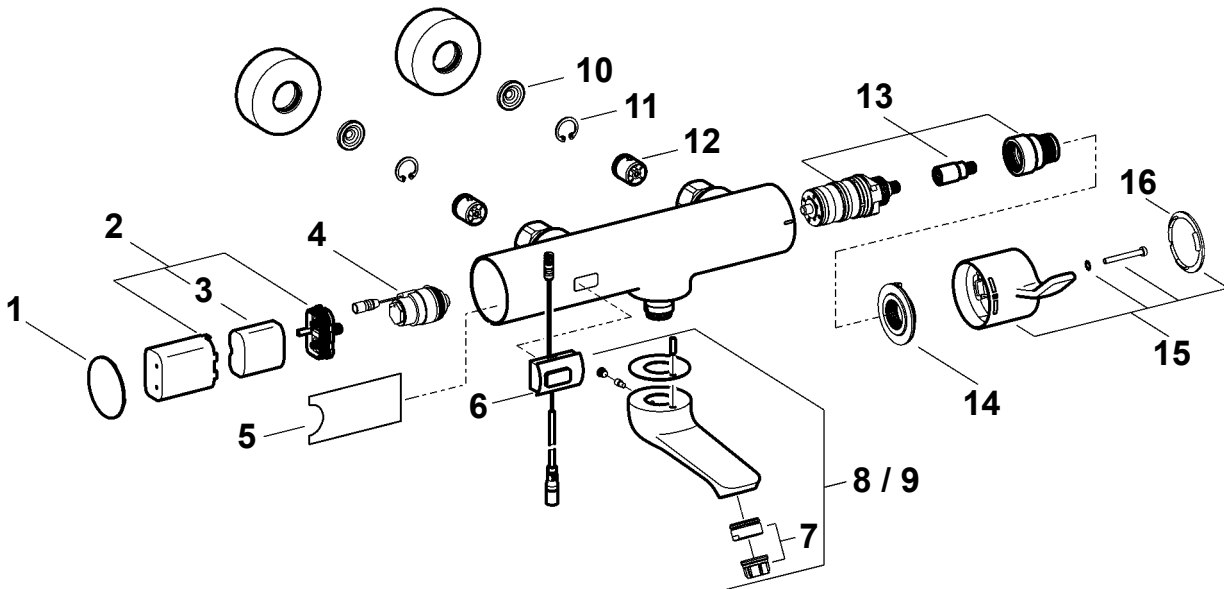

1 3600000208 ASET1013	7 3600001803 ASXX1044	12 ... 2000104687 ^{a)} ASXX9010
2 3600002063 ACEX9023	8 115 mm 2030071293 ASLT1006	13 ... 3600000103 ASET1011
3 2000104846 EPRTR0008	9 200 mm 3600000086 ASLT1007	14 ... 2030003296 EAQLT0003
4 3600000214 ASET1012	10 ... 2000104706 ^{a)} ASXX9011	15 ... 2030003254 EAQLT0001
5 2030053034 ^{a)} ASET2010	11 ... 2000104721 ^{b)} ASXX9034	16 ... 2030003258 EAQLT0002
6 3600000550 ASEM1012		

EN a) 10 pieces b) 2 pieces	ES a) 10 piezas b) 2 piezas	PL a) 10 sztuk b) 2 sztuk	FI a) 10 kappaletta b) 2 kappaletta
DE a) 10 Stück b) 2 Stück	IT a) 10 pezzi b) 2 pezzi	SV a) 10 styck b) 2 styck	RU a) 10 штук b) 2 штук
FR a) 10 pièces b) 2 pièces	NL a) 10 stuk b) 2 stuk	CS a) 10 kusů b) 2 kusů	

23. Zubehör

EN Accessories
FR Accessoire
ES Accesorios
IT Accessori

NL Toebehoren
PL Akcesoria
SV Tillbehör

CS Příslušenství
FI Lisävarusteet
RU принадлежности

1

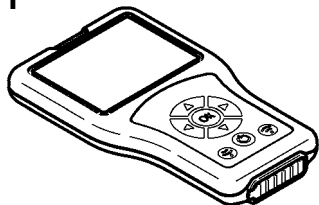

2



1..... 2030036654
ACEX9005

2..... 2030036849
ACEX9004

3..... 3600000432
ACET1005

4..... 2030047203
ACXX9003

5..... 2000104778
ZTAPS0005

6..... 2030071309 ^{a)}
ASXX1042

3

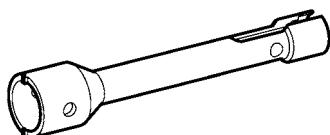

4

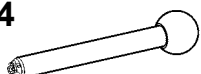

5

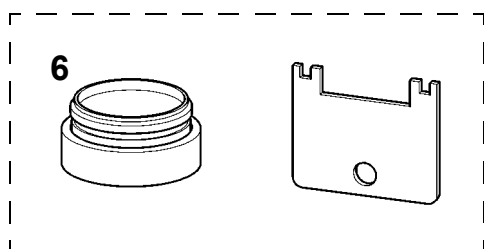

6

EN a) 10 pieces

ES a) 10 piezas

PL a) 10 sztuk

FI a) 10 kappaletta

DE a) 10 Stück

IT a) 10 pezzi

SV a) 10 styck

RU a) 10 штук

FR a) 10 pièces

NL a) 10 stuk

CS a) 10 kusů

Notizen

EN Notes

FR Notes

ES Notas

IT Annotazioni

NL Notities

PL Uwagi

SV Notiser

CS Poznámky

FI Muistiinpanot

RU Примечания

Notizen

EN Notes

FR Notes

ES Notas

IT Annotazioni

NL Notities

PL Uwagi

SV Notiser

CS Poznámky

FI Muistiinpanot

RU Примечания

Australia

PR Kitchen and
Water Systems Pty Ltd
Dandenong South VIC 3175
Phone +61 3 9700 9100

Austria

KWC Austria GmbH
6971 Hard, Austria
Phone +43 5574 6735 0

**Belgium, Netherlands &
Luxembourg**

KWC Aquarotter GmbH
9320 Aalst; Belgium
Phone NL +31 (0) 492 728 224
BE/LU +32 (0) 53 60 31 50

Czech Republic

KWC Aquarotter GmbH
14974 Ludwigsfelde, Germany
Phone +49 3378 818 309

France

KWC Austria GmbH
6971 Hard, Austria
Phone +33 800 909 216

Germany

KWC Aquarotter GmbH
14974 Ludwigsfelde
Phone +49 3378 818 0

Italy

KWC Austria GmbH
6971 Hard, Austria
Numero Verde +39 800 789 233

Middle East

KWC ME LLC Ras Al Khaimah,
United Arab Emirates
Phone +971 7 2034 700

Poland

KWC Aquarotter GmbH
14974 Ludwigsfelde, Germany
Phone +48 58 35 19 700

Spain

KWC Austria GmbH
6971 Hard, Austria
Phone +43 5574 6735 211

Switzerland & Liechtenstein

KWC Group AG
5726 Unterkulm, Switzerland
Phone +41 62 768 69 00

Turkey

KWC ME LLC Ras Al Khaimah,
United Arab Emirates
Phone +971 7 2034 700

United Kingdom

KWC DVS Ltd - Northern Office
Barlborough S43 4PZ
Phone +44 1246 450 255

KWC DVS Ltd - Southern Office
Paignton TQ4 7TW
Phone +44 1803 529 021

EAST EUROPE

Bosnia Herzegovina
Bulgaria | Croatia
Hungary | Latvia
Lithuania | Romania
Russia | Serbia | Slovakia
Slovenia | Ukraine

KWC Aquarotter GmbH
14974 Ludwigsfelde, Germany
Phone +49 3378 818 261

SCANDINAVIA & ESTONIA

Finland | Sweden | Norway
Denmark | Estonia

KWC Nordics Oy
76850 Naarajärvi, Finland
Phone +358 15 34 111

OTHER COUNTRIES

KWC Austria GmbH
6971 Hard, Austria
Phone +43 5574 6735 0

