

# EXOS.

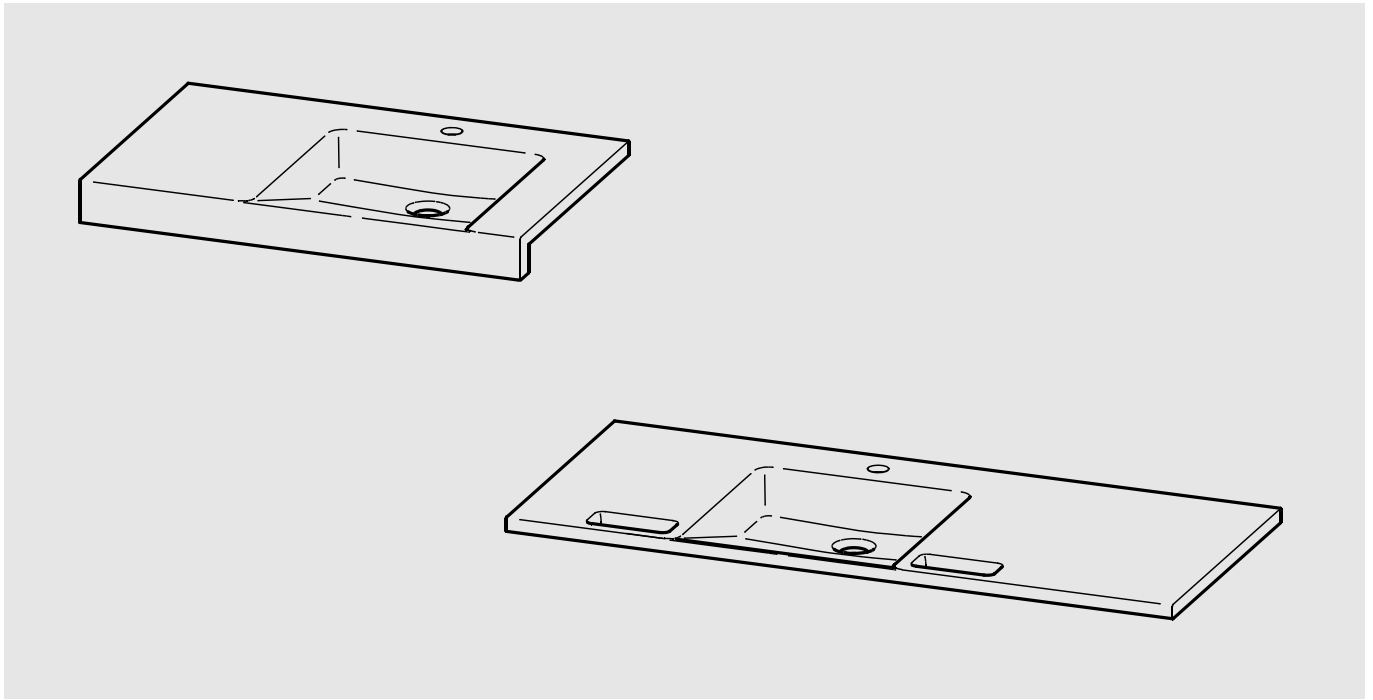

DE	Montage- und Betriebsanleitung	Reihenwaschtisch
EN	Installation and operating instructions	multiple washbasin
FR	Notice de montage et de mise en service	Lavabo collectif
ES	Instrucciones de montaje y servicio	Lavabo en hilera
IT	Istruzioni per il montaggio e l'uso	Lavabo multiplo
NL	Montage- en bedrijfsinstructies	seriewastafel
PL	Instrukcja montażu i obsługi	Umywalka szeregowa
SV	Monterings- och driftinstruktion	Tvättställ
CS	Návod pro montáž a provoz	Řadové umyvadlo
FI	Asennus- ja käyttöohje	Sarjapesuallas
RU	Инструкция по монтажу и вводу в эксплуатацию	

EN BF: Grab rail

DE BF: Haltegriff

PL BF: Poręcz

SV BF: Stödhandtag

FR BF: Poignée

CS BF: Madlo

ES BF: Barra de agarre

FI BF: Tukikaide

IT BF: Corrimano

RU BF:

NL BF: Handgreep



## EXOS.

I

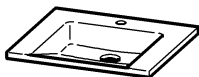

II

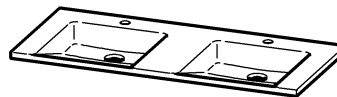

III

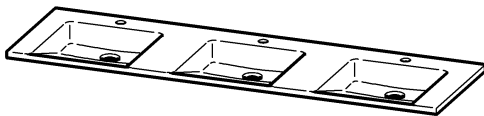

IV

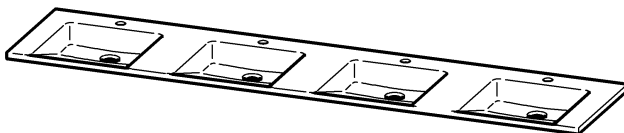

V

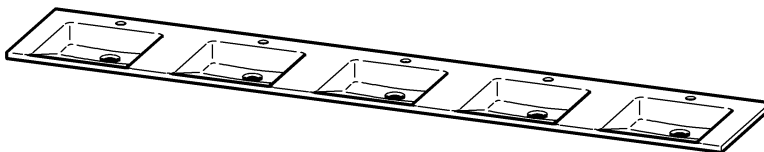

VI

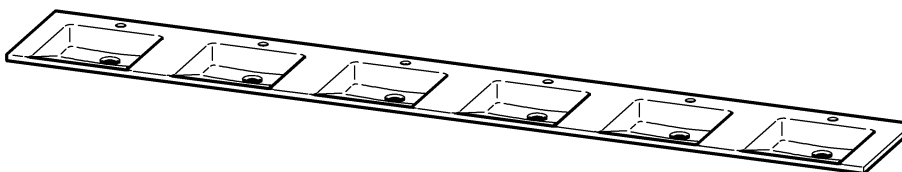

# EXOS. BF

VII

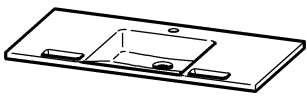

VIII

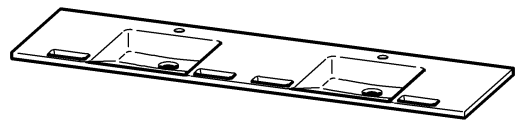

IX

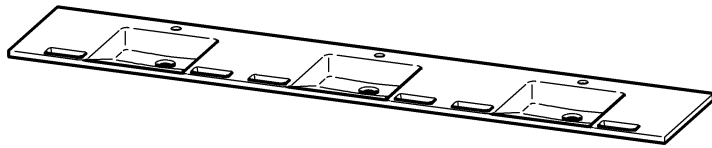

X

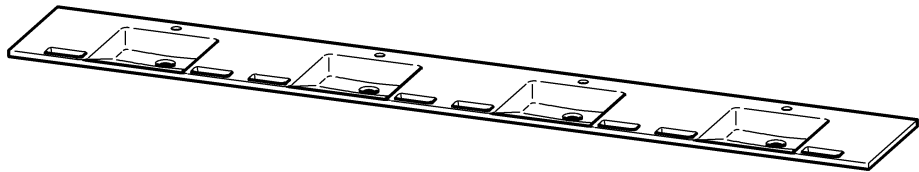

	I	II	III	IV	V	VI	VII	VIII	IX	X
	1x	2x	3x	4x	5x	6x	1x	2x	3x	4x

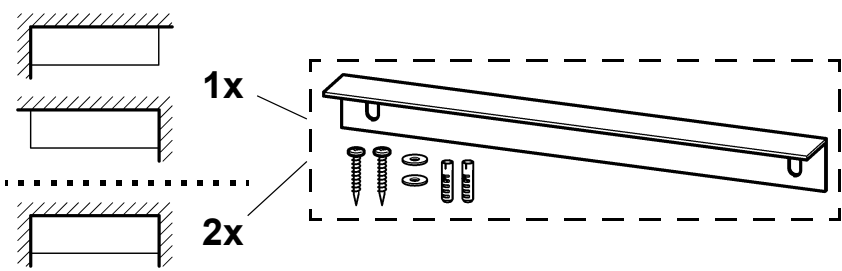
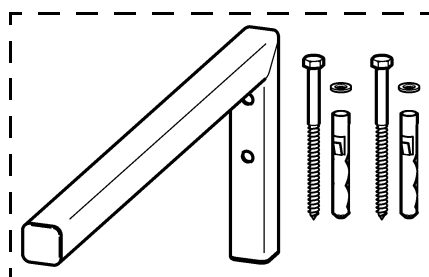
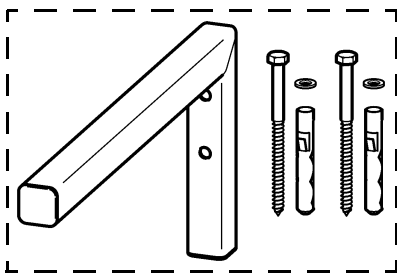

**EN**

- ▶ The design of the unit with trough type, installation type, washbasin contour, drill holes and recesses for accessories can be found in the customer's drawing.
- ▶ The number of pieces of fastening material depends on the design and the total length.

**PL**

- ▶ Projekt urządzenia z typem wycięcia, typem zabudowy, konturem szafki, otworami i wgłębieniami na akcesoria zawiera rysunek klienta.
- ▶ Ilość materiałów mocujących jest zależna od wersji i długości łącznej.

**FR**

- ▶ La réalisation du système avec type de creux, emplacement, contour du lavabo, alésages et évidements pour les accessoires figure dans le dessin du client.
- ▶ Le nombre de matériels de fixation dépend de la réalisation et de la longueur totale.

**ES**

- ▶ El diseño de la instalación con el tipo de cubeta, el tipo de montaje, el contorno del lavabo, los orificios y las escotaduras para los accesorios deben consultarse en el esquema para el cliente.
- ▶ El número de unidades del material de fijación depende del diseño y de la longitud total

**IT**

- ▶ L'esecuzione dell'impianto con modello di bacinella, tipo di montaggio, contorno del lavabo, fori e aperture per gli accessori va tratta dal disegno del cliente.
- ▶ La quantità di pezzi del materiale di montaggio dipende dall'esecuzione e dalla lunghezza totale.

**NL**

- ▶ Het ontwerp van het toestel, inclusief het goottype, het inbouwtype, de wasbakcontour, de boorgaten en de uitsparingen voor toebehoren, moet worden afgeleid van de tekening van de klant.
- ▶ Het aantal bevestigingsmaterialen is afhankelijk van de uitvoering en de totale lengte.

**DE**

- ▶ Die Ausführung der Anlage mit Muldentyp, Einbauart, Waschtischkontur, Bohrungen und Aussparungen für Accessoires sind der Kundenzeichnung zu entnehmen.
- ▶ Die Stückzahl des Befestigungsmaterial ist abhängig von der Ausführung und der Gesamtlänge.

**SV**

- ▶ Anläggningens utförande med typ av fördjupning, monteringsätt, tvättställskontur, borrhål och urtag för tillbehör framgår av kundritningen.
- ▶ Antalet fästelement beror på utförande och total längd.

**CS**

- ▶ Provedení jednotky s typem žlabu, způsobem instalace, obrysem umyvadla, otvory a výklenky na příslušenství je třeba převzít z výkresu zákazníka.
- ▶ Počet kusů upevňovacího materiálu závisí na provedení a celkové délce.

**FI**

- ▶ Järjestelmän rakenne syvennystyyppin, asennustyyppin, pesualtaan muodon, reikien ja lisävarusteiden aukkojen kanssa löytyy asiakkaan piirustuksesta.
- ▶ Kiinnitysmateriaalienn lukumäärä riippuu toteutuksesta ja kokonaispituudesta.

**RU**

- ▶ Выполнение установки, включая тип ванны, способ установки, контур умывальника, отверстия и ниши для аксессуаров, можно взять из чертежа заказчика.
- ▶ Спецификация крепежного материала зависит от исполнения и общей длины.

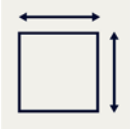

**ZANMW0021,  
ZANMW0025**

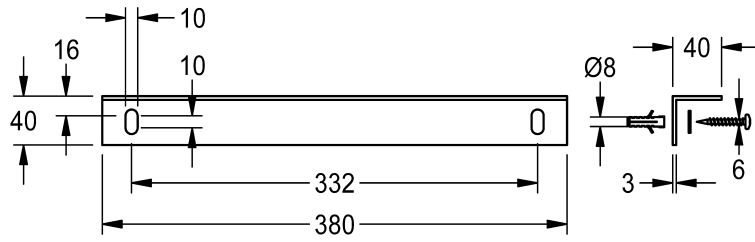

**ZANMW0023,  
ZANMW0027**

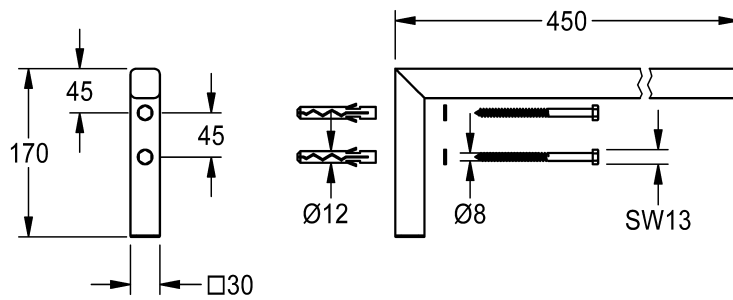

**ZANMW0024,  
ZANMW0028**

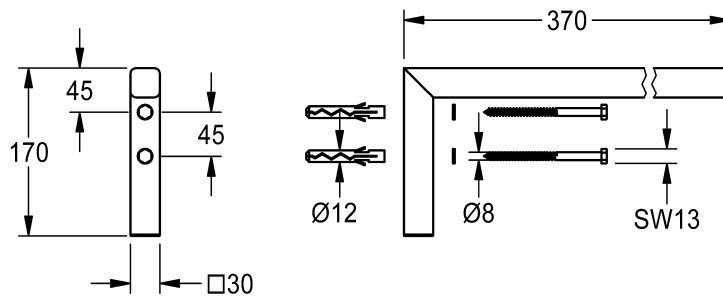

**EXOS.**

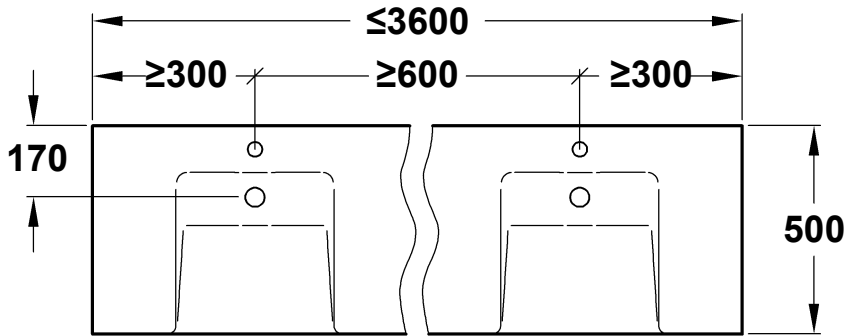
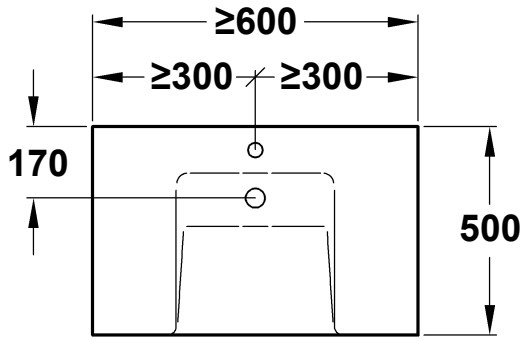

**EXOS. BF**

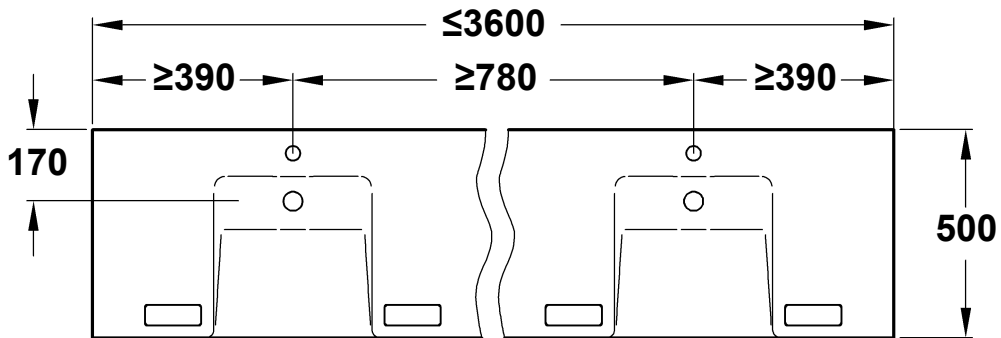
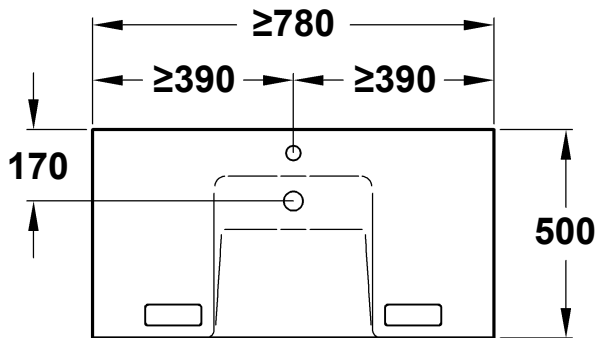

## EXOS., / EXOS. BF

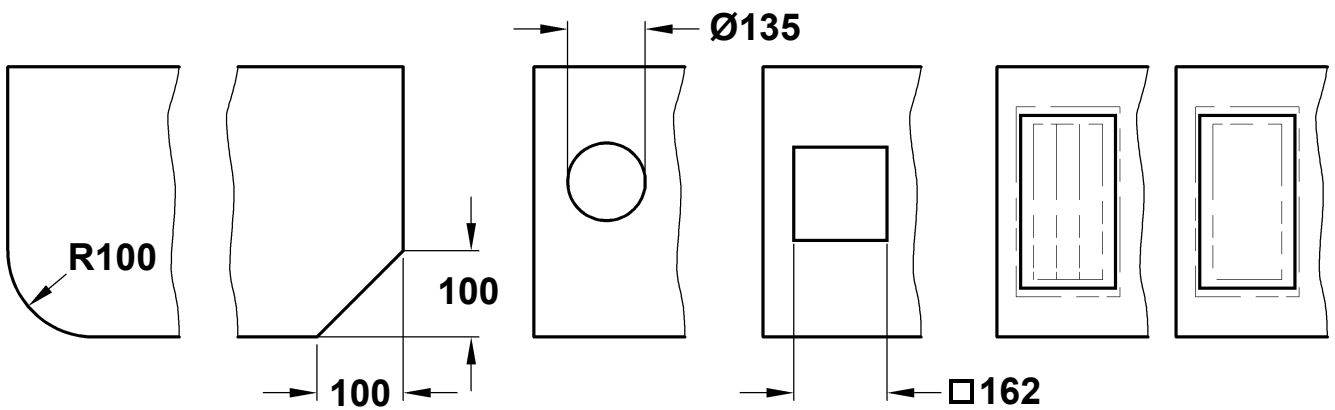
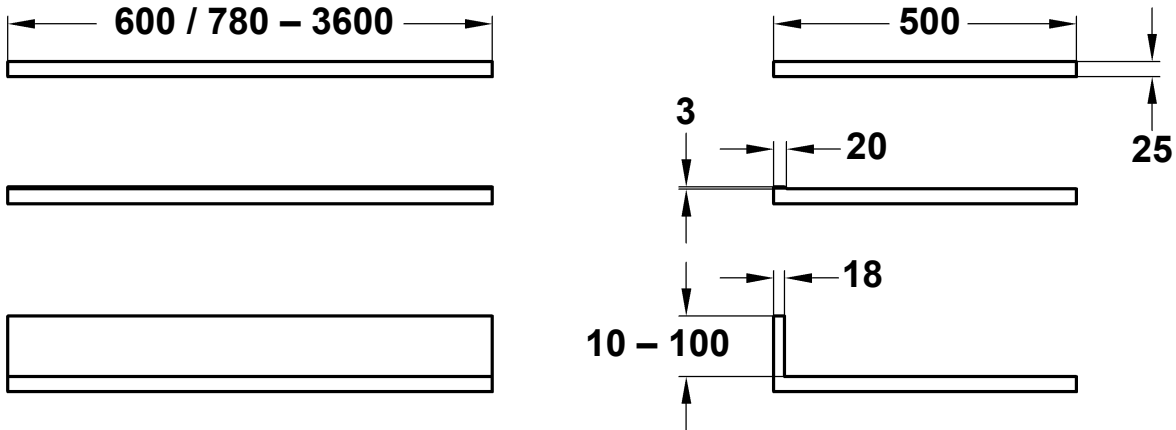

## EXOS.

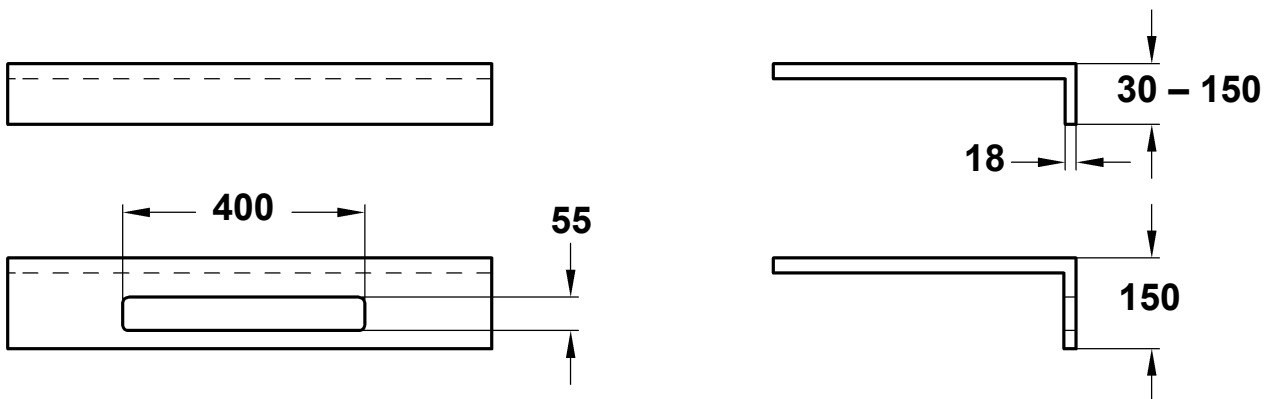

- |  |   |
|--|---|
| <p><b>EN</b></p> <p>► The dimensions of the system can be found in the customer drawing.</p> <p><b>PL</b></p> <p>► ymiary instalacji podano na rysunku.</p> <p><b>FR</b></p> <p>► Les dimensions de l'installation sont indiquées sur le plan du client.</p> | <p><b>DE</b></p> <p>► Die Maße der Anlage sind der Kundenzeichnung zu entnehmen.</p> <p><b>SV</b></p> <p>► Anläggningens mått anges i kundritningen.</p> <p><b>CS</b></p> <p>► Rozměry zařízení jsou přizpůsobeny návrhu klienta.</p> |
|--|---|

**ES**

- ▶ Las dimensiones de la instalación se encuentran en el esquema para el cliente.

**IT**

- ▶ Le dimensioni dell'impianto si deducono dal progetto del cliente.

**NL**

- ▶ De afmetingen van de installatie zijn in de klanttekening terug te vinden.

**FI**

- ▶ Laitteiston mitat löytyvät asiakaspiirroksesta.

**RU**

- ▶ Размеры установки приведены на чертеже заказчика.

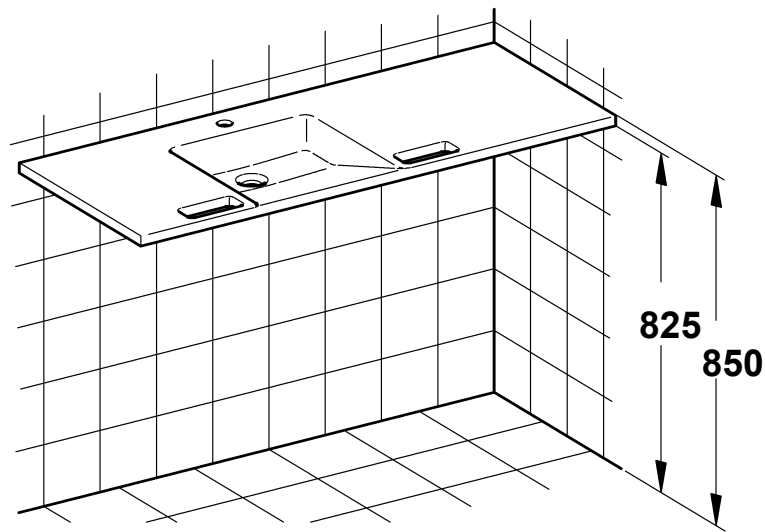
**EN****Installation and operating instructions****Important notes**

- ▶ Incorrect storage can warp and damage the washbasin.
- ▶ Store the washbasin in its original packaging.
- ▶ Do not use abrasive cleaners for cleaning.
- ▶ When using abrasive cleaners containing acids or alkaline solutions, close attention must be paid to the directions for use.
- ▶ The cast mineral material can be disposed of as regular domestic waste.
- ▶ For the colour white, the temperature resistance is 80 °C and for other colours 65 °C.

**DE****Montage- und Betriebsanleitung****Wichtige Hinweise**

- ▶ Bei falscher Lagerung kann sich der Waschtisch verziehen und beschädigt werden.
- ▶ Waschtisch in der Originalverpackung lagern.
- ▶ Zur Reinigung nicht scheuernde Reinigungsmittel verwenden.
- ▶ Bei Verwendung von säure- oder laugenhaltigen Reinigern sind die Anwendungsvorschriften einzuhalten.
- ▶ Der Mineralguss kann im normalen Hausmüll entsorgt werden.
- ▶ Die Temperaturbeständigkeit bei der Farbe Alpinweiß beträgt 80 °C und bei anderen Farben 65 °C.



**PL**

## Instrukcja montażu i obsługi

### Ważne wskazówki

- ▶ W przypadku nieprawidłowego składowania umywalka może ulec uszkodzeniu pod wpływem naprężeń.
- ▶ Umywalkę przechowywać w oryginalnym opakowaniu.
- ▶ Do czyszczenia nie stosować środków trących.
- ▶ Podczas używania środków czyszczących zawierających kwasy lub ług należy przestrzegać przepisów dotyczących ich stosowania.
- ▶ Odlew mineralny można wyrzucać razem ze zwykłymi odpadami domowymi.
- ▶ Wytrzymałość temperaturowa w przypadku koloru białego wynosi 80 °C, w przypadku pozostałych kolorów 65 °C.

**SV**

## Monterings- och driftinstruktion

### Viktiga informationer

- ▶ Vid felaktig förvaring kan handfatet vridas och skadas.
- ▶ Förvara handfatet i originalförpackningen.
- ▶ Använd inte repande rengöringsmedel för rengöring.
- ▶ Följ bruksanvisningarna vid användning av syra- eller luthaltiga rengöringsmedel.
- ▶ Mineralmaterialet kan slängas i de vanliga hushållssoporna.
- ▶ Temperaturbeständigheten är 80 °C för färgen vit och 65 °C för övriga färger.

**FR**

## Notice de montage et de mise en service

### Remarques importantes

- ▶ En cas d'entreposage incorrect, le lavabo peut se déformer et être endommagé.
- ▶ Entreposer le lavabo dans l'emballage d'origine.
- ▶ Ne pas utiliser de produit abrasif pour le nettoyage.
- ▶ Lors de l'utilisation de détergents contenant des acides ou des lessives, respecter les consignes d'utilisation.
- ▶ La fonte minérale peut être éliminée dans les ordures ménagères.
- ▶ La résistance aux chocs thermiques est de 80 °C pour le coloris blanc et de 65 °C pour les autres coloris.

**CS**

## Návod pro montáž a provoz

### Důležité pokyny

- ▶ Při nesprávném skladování se může umyvadlový stůl zdeformovat a poškodit.
- ▶ Umyvadlový stůl skladujte v originálním obalu.
- ▶ Na čištění nepoužívejte abrazivní čisticí prostředky.
- ▶ Při používání čisticích prostředků s obsahem kyselin nebo louhů dodržujte návody k použití.
- ▶ Polymerbeton je možné likvidovat jako běžný domácí odpad.
- ▶ Teplotní odolnost v případě bílé barvy činí 80 °C, u ostatních barev pak 65 °C.

**ES**

## Instrucciones de montaje y servicio

### Indicaciones importantes

- ▶ Si no se almacena adecuadamente, el lavabo puede desplazarse de su posición y sufrir daños.
- ▶ Almacene el lavabo en su embalaje original.
- ▶ No utilizar productos de limpieza abrasivos en la limpieza.
- ▶ Si se utilizan limpiadores que contengan ácidos o lejías se habrán de respetar las Instrucciones de empleo.
- ▶ La fundición de mineral se puede eliminar junto con la basura doméstica normal.
- ▶ La resistencia térmica del color blanco es de 80 °C, y del resto de colores de 65 °C.

**FI**

## Asennus- ja käyttöohje

### Tärkeitä ohjeita

- ▶ Väärän varastoinnin seurauksena pesupöytä voi kiertyä ja vaurioitua.
- ▶ Varastoi pesupöytä sen alkuperäispakkauksessa.
- ▶ Älä käytä puhdistukseen hankaavia puhdistusaineita.
- ▶ Mikäli käytät happo- tai emäspitoisia puhdistusaineita, noudata käyttöohjeen määräyksiä.
- ▶ Keramiikkavalun voit hävittää tavallisena talousjätteenä.
- ▶ Valkoisen värin lämpötilankestävyys on 80 °C ja muilla väreillä 65 °C.

**IT**

## Istruzioni per il montaggio e l'uso

### Avvertenze importanti

- ▶ In caso di stoccaggio errato, rischio di deformare e danneggiare il lavabo.
- ▶ Stoccare il lavabo nell'imballaggio originale.
- ▶ Per la pulizia non utilizzare detergenti abrasivi.
- ▶ Rispettare le istruzioni per l'uso quando si utilizzano detergenti acidi o basici.
- ▶ La ghisa minerale può essere smaltita nei normali rifiuti domestici.
- ▶ Nel caso del colore bianco, la resistenza termica è di 80 °C; con gli altri colori è di 65 °C.

**RU**

## Инструкция по монтажу и вводу в эксплуатацию

### Важные указания

- ▶ Неправильное хранение раковины может привести к ее деформации и повреждению.
- ▶ Храните раковину в оригинальной упаковке.
- ▶ Для чистки не используйте абразивные чистящие средства.
- ▶ При использовании чистящих средств, содержащих кислоты или щелочи, соблюдайте инструкции по применению.
- ▶ Изделия из минерального литья могут быть утилизированы вместе с обычными бытовыми отходами.
- ▶ Устойчивость к изменениям температуры при использовании белой краски составляет 80 °C, при использовании других красок — 65 °C.

**Belangrijke aanwijzingen**

- ▶ Bij een incorrecte opslag kan de wastafel vervormd en beschadigd raken.
- ▶ Bewaar de wastafel in de originele verpakking.
- ▶ Voor de reiniging geen schurende reinigingsmiddelen gebruiken.
- ▶ Bij het gebruik van zuur- of looghoudende reinigingsmiddelen moeten de gebruiksvorschriften in acht worden genomen.
- ▶ Het polymerebeton kan met het normale huisvuil worden afgevoerd.
- ▶ De temperatuurbestendigheid bedraagt 80 °C bij de kleur wit en 65 °C bij andere kleuren.

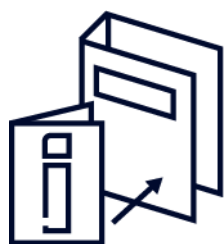

# 1. Montage

EN Installation  
FR Montage  
ES Montaje  
IT Montaggio

NL Montage  
PL Montaż  
SV Montering

CS Montáž  
FI Asennus  
RU Монтаж

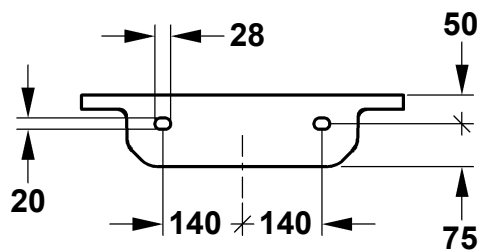
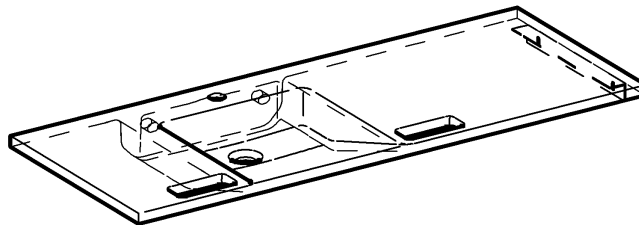
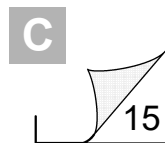
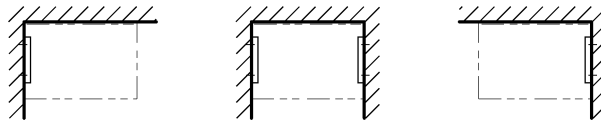
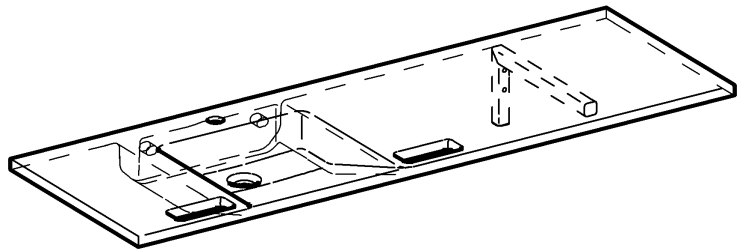
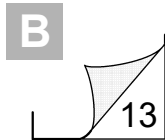
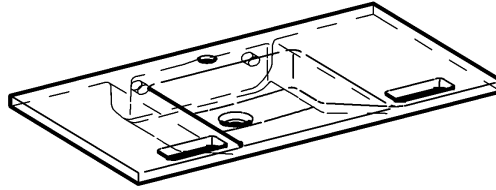
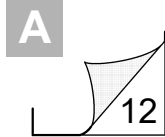
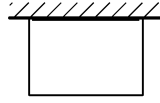

A

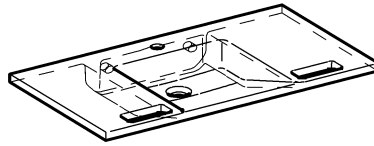

8 mm  
17 mm



14 mm

1

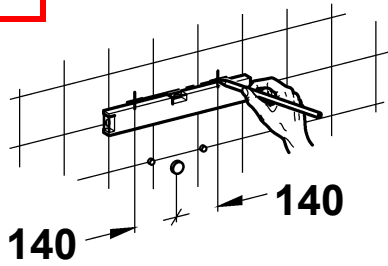

2

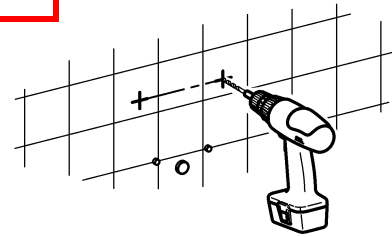

3

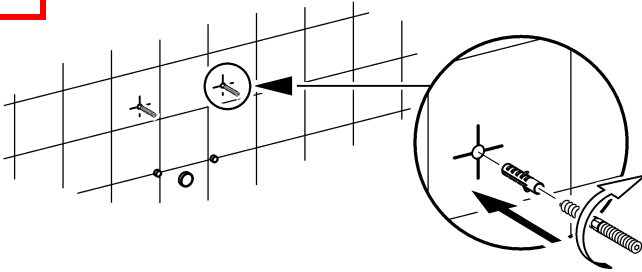

4

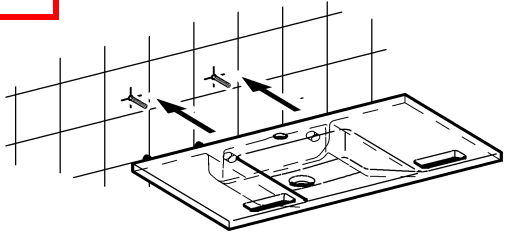

5

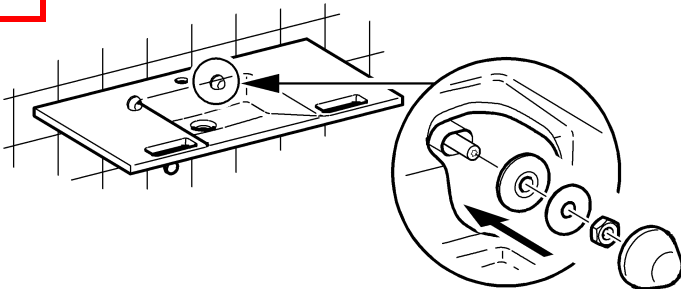

6

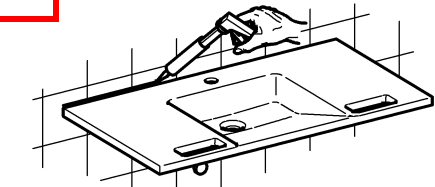

**B**

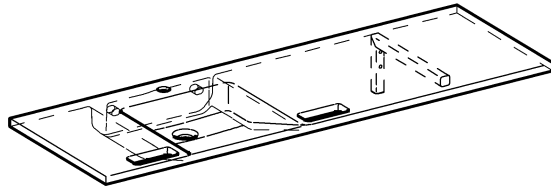

8 mm  
10 mm  
17 mm



12 mm  
14 mm

**1**

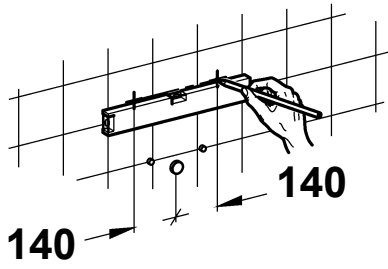

**2**

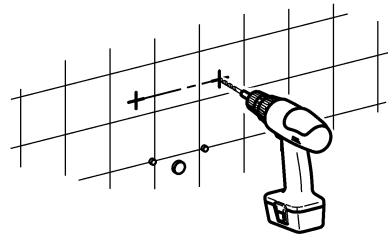

**3**

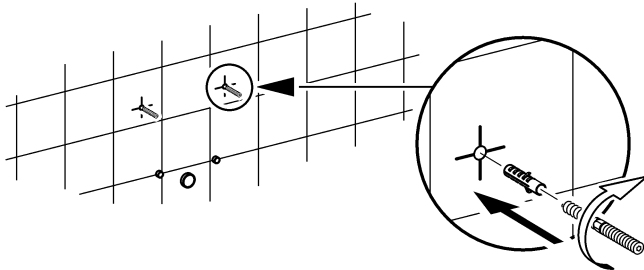

**4**

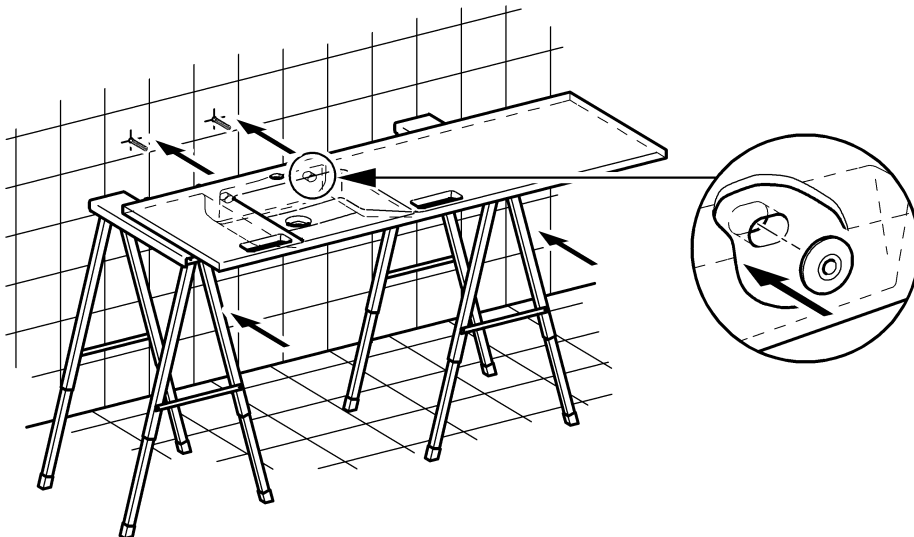

5

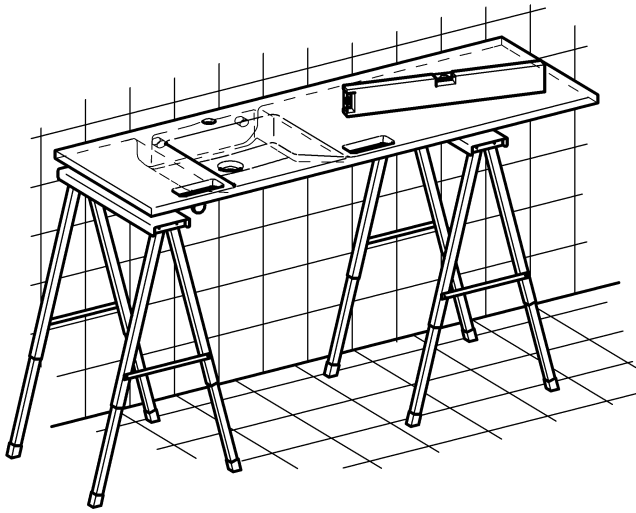

6

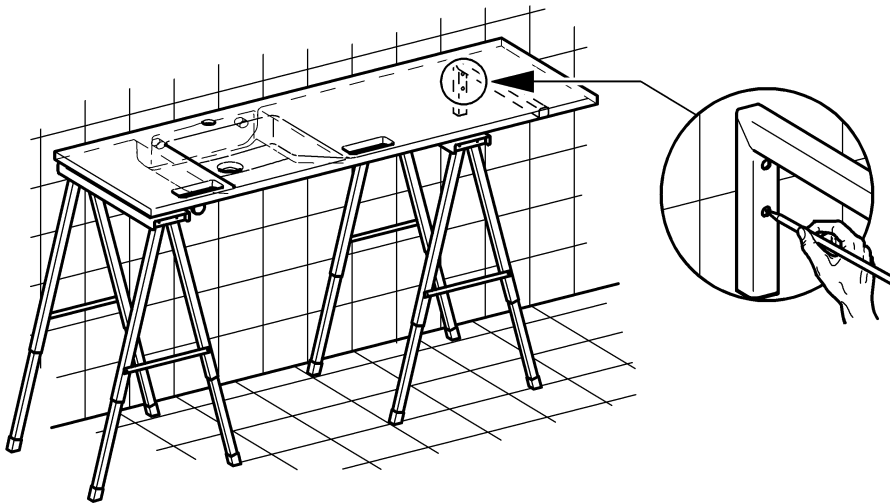

7

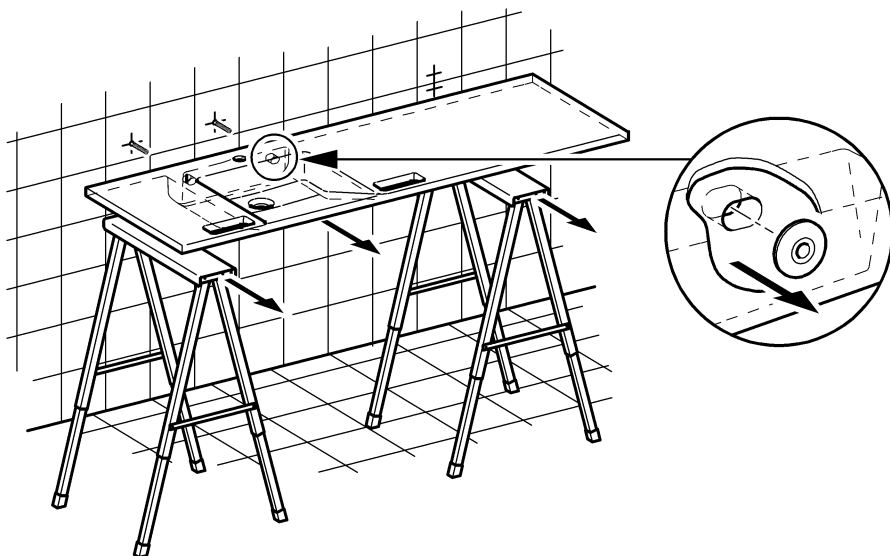

**8**

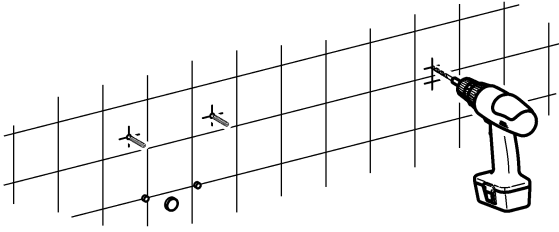

**9**

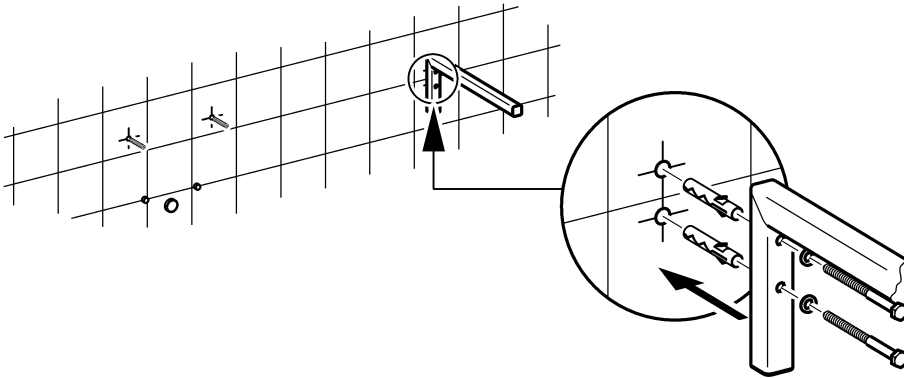

**10**

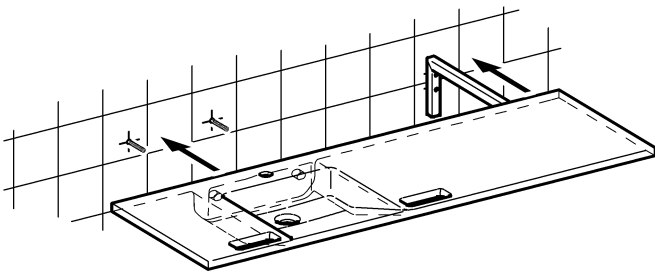

**11**

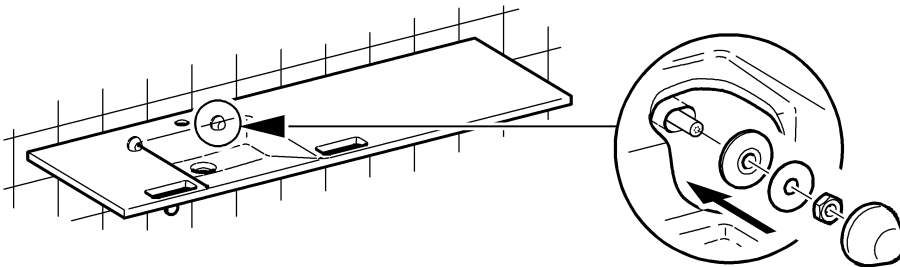

**12**

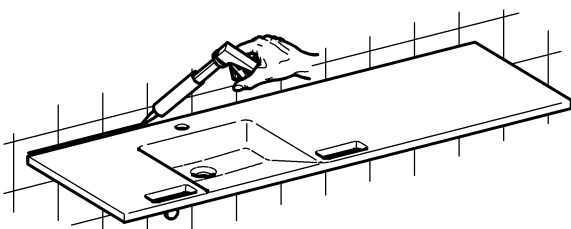



C

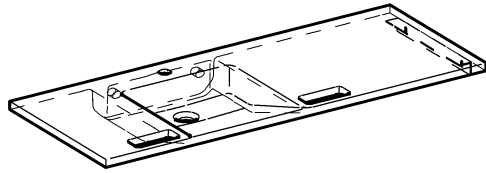

8 mm  
17 mm



8 mm  
14 mm

1

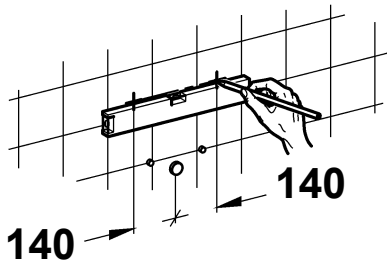

2

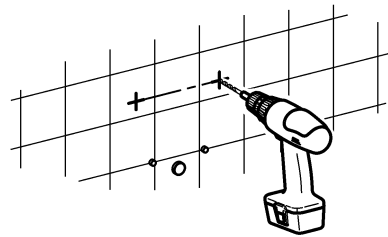

3

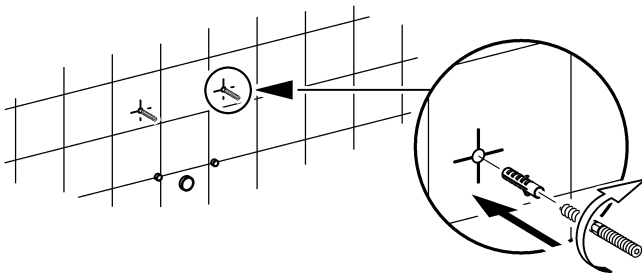

4

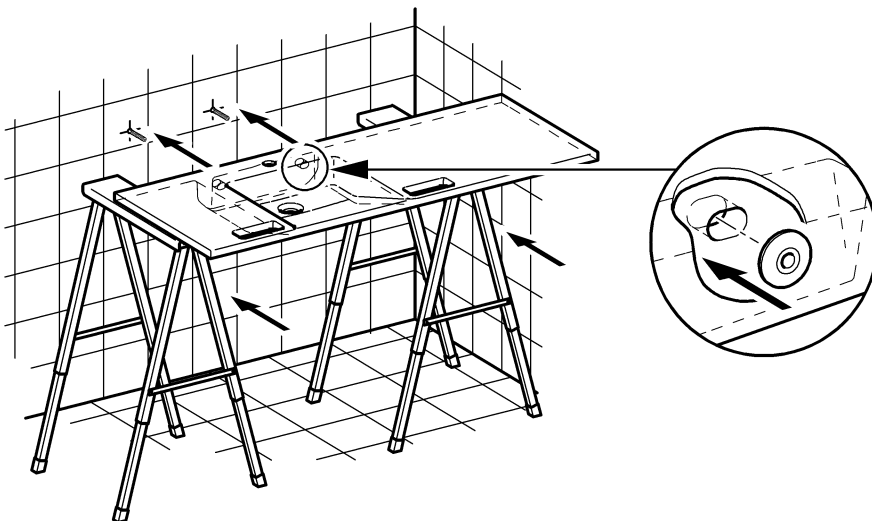

5

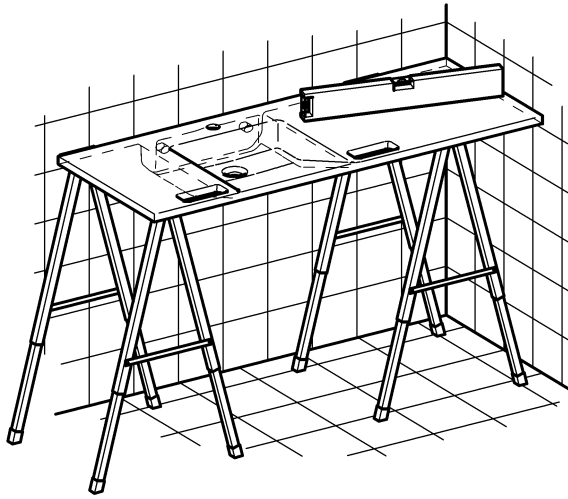

6

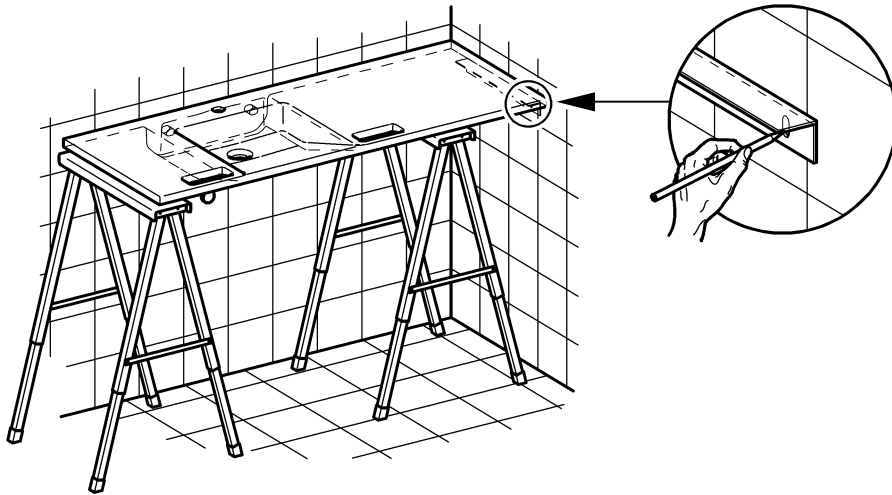

7

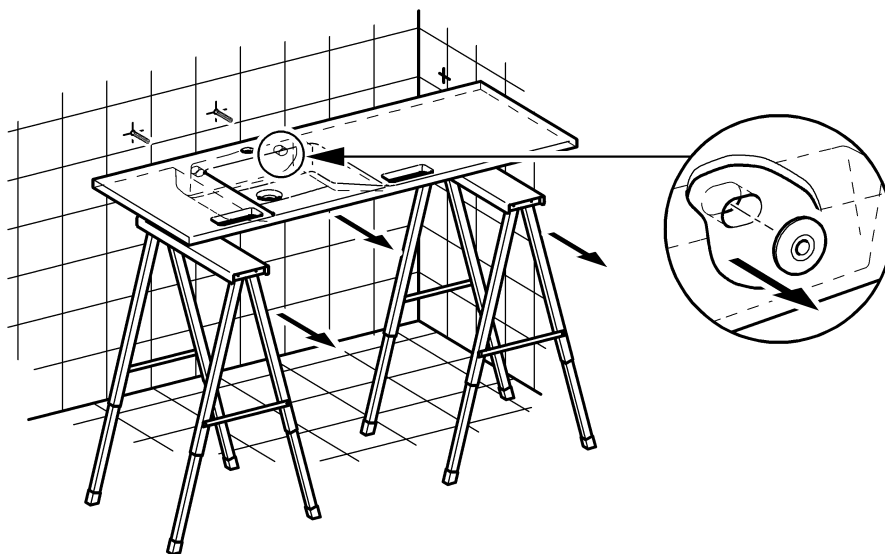

**8**

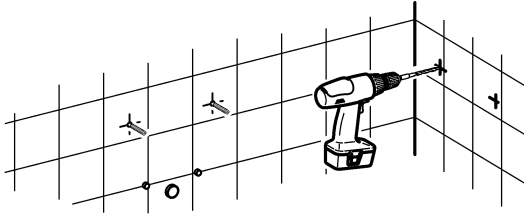

**9**

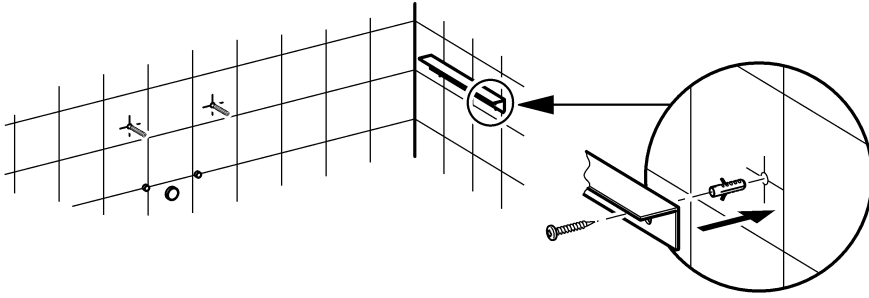

**10**

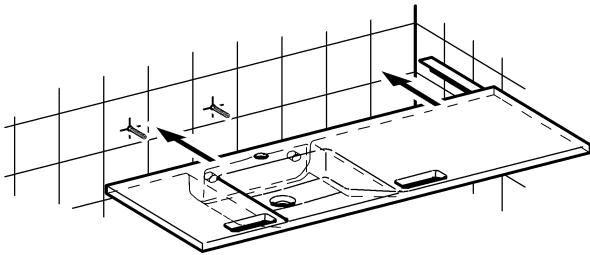

**11**

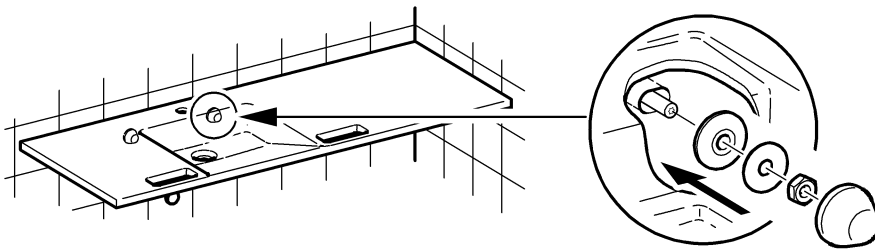

**12**

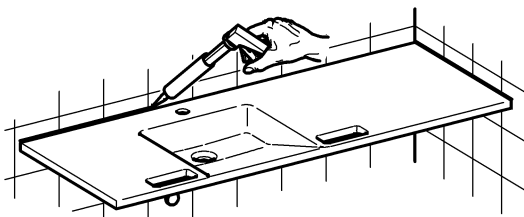

## 2. Nischenmaße ermitteln

EN Determine niche size

NL Nismaten bepalen

CS Zjistěte rozměry výklenku.

FR Déterminer les dimensions de la niche

PL Ustalić wymiary wnęk

FI Raon koon määrittäminen

ES Determinar medidas del nicho

SV Fastställa nischmått

RU Определение размеров ниши

IT Determinare le dimensioni della nicchia

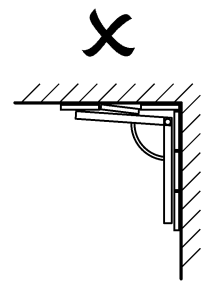
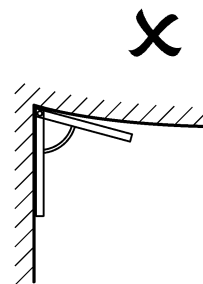
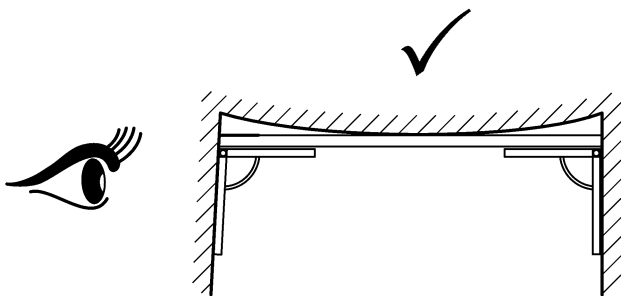
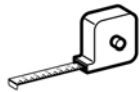

1

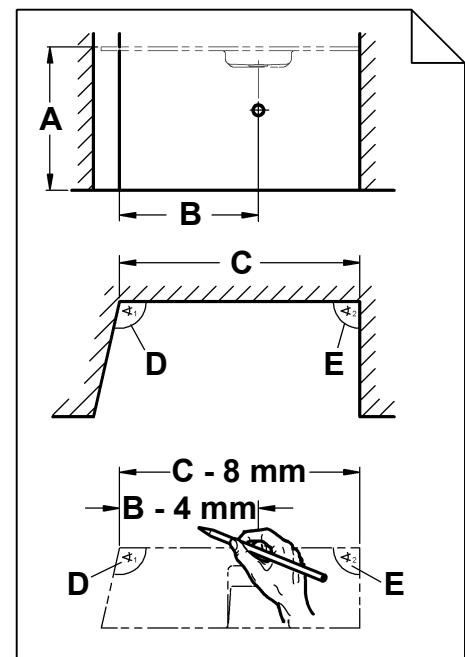
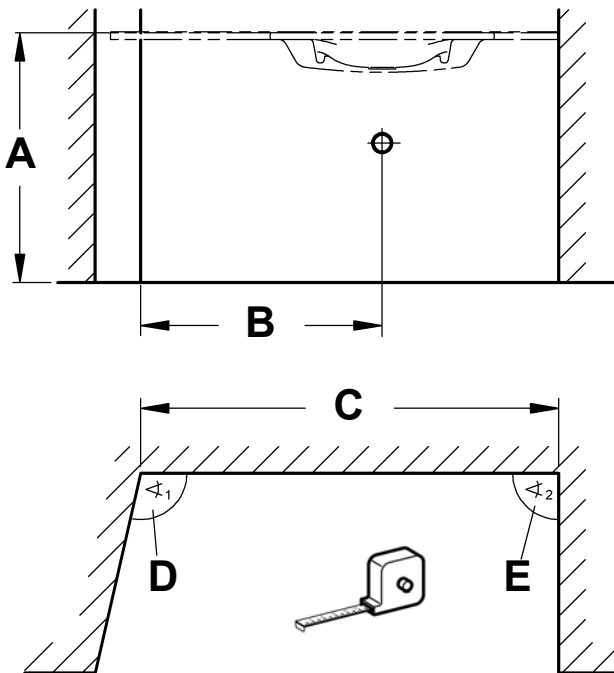

### 3. Waschtischlänge anpassen

EN Adapt length of washbasin	NL Wastafellengte aanpassen	CS Zjistěte rozměry výklenku.
FR Ajuster la longueur du lavabo	PL Dopasować długość umywalki	FI Pesualtaan pituuden muokkaus
ES Adaptar longitud del lavabo	SV Anpassa tvättställslängd	RU Подгонка длины умывальника
IT Adattare la lunghezza del lavabo		

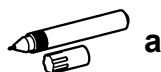
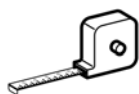

- |   |  |
|---|--|
| <b>EN</b> a: Water-resistant pen<br>b: Masking tape<br>c: Deburr with fine abrasive paper                                 | <b>DE</b> a: wasserfester Stift<br>b: Kreppband<br>c: entgraten mit feinem Schleifpapier                                 |
| <b>PL</b> a: przetyczka wodoodporna<br>b: aśma maskująca<br>c: wygładzenie drobnym papierem ściernym                      | <b>SV</b> a: Vattenfast penna<br>b: Elastiskt tejp (kräpptejp)<br>c: Avgradning med fint slippapper                      |
| <b>FR</b> a: stylo qui résiste à l'eau<br>b: Bande crêpée<br>c: ébavurer avec du papierémeri fin                          | <b>CS</b> a: voděodolný kolík<br>b: kreповá páska<br>c: odjehlit jemným brusným papírem                                  |
| <b>ES</b> a: pasador a prueba de agua<br>b: cinta de crepé<br>c: desbarbado con papel de lija fino                        | <b>FI</b> a: vedenpitävä kynä<br>b: kreppinauha<br>c: jäysteenpoisto hienolla hiomapaperilla                             |
| <b>IT</b> a: spinotto impermeabile all'acqua<br>b: Nastro di carta crespata<br>c: sbavare con carta abrasiva a grana fine | <b>RU</b> a: водостойкий маркер<br>b: клейкая лента<br>c: зачищать заусенцы с помощью мелкозернистой шлифовальной бумаги |
| <b>NL</b> a: watervaste stift<br>b: schildersplakband<br>c: ontbramen met fijn schuurpapier                               |  |

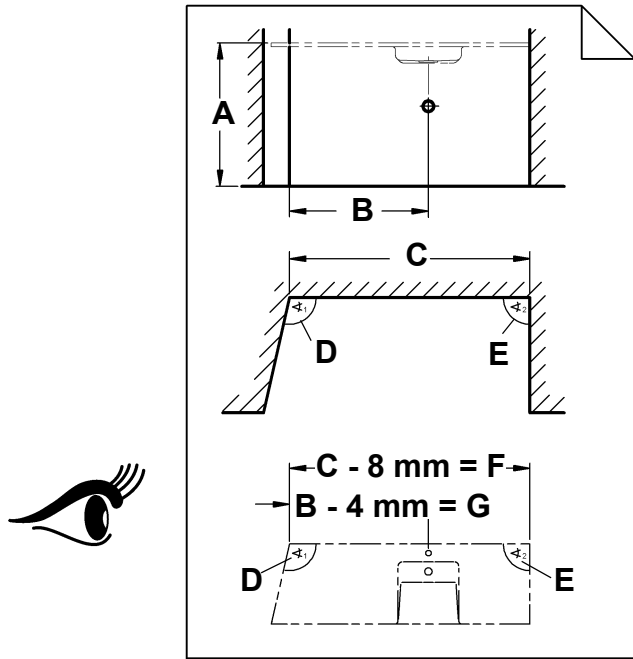

**1**

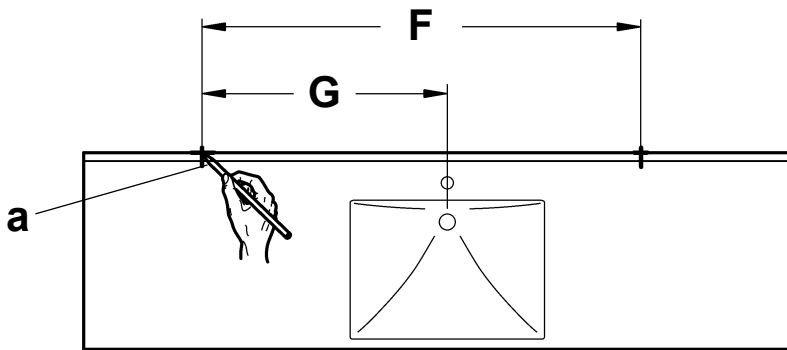

**2**

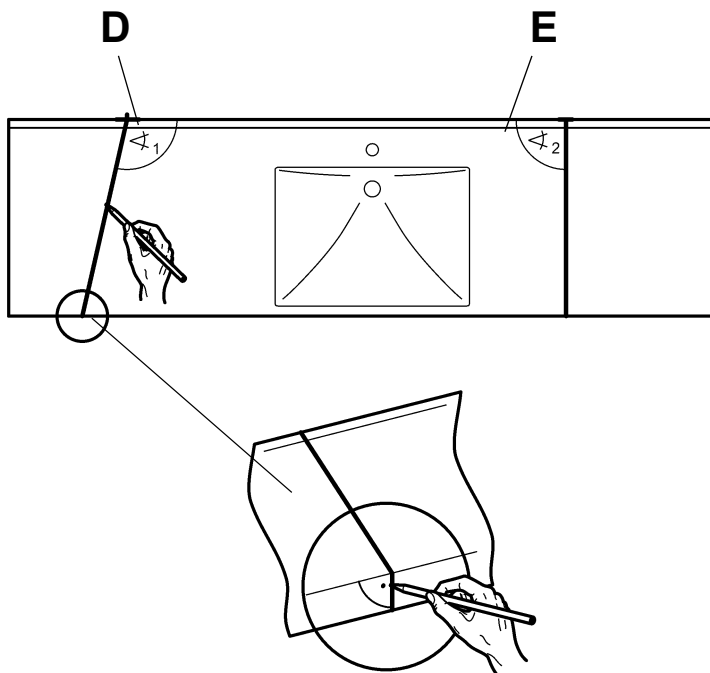

**3**

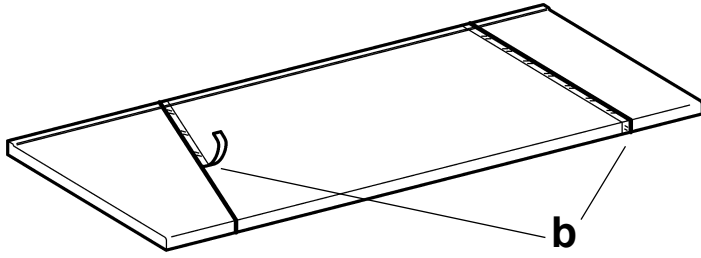

**4**

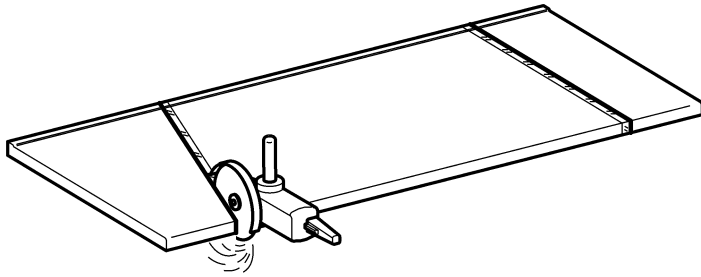

**5**

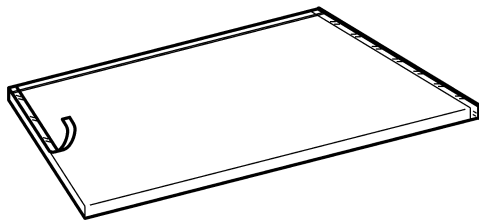

**6**

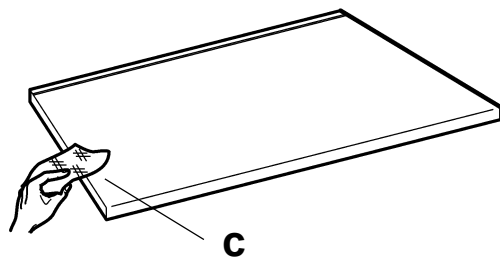

## 4. Ersatzteile

EN Replacement parts  
FR Pièces de rechange  
ES Piezas de recambio  
IT Pezzi di ricambio

NL Reserveonderdelen  
PL Części zamienne  
SV Reservdelar

CS Náhradní díly  
FI Varaosat  
RU Запчасти

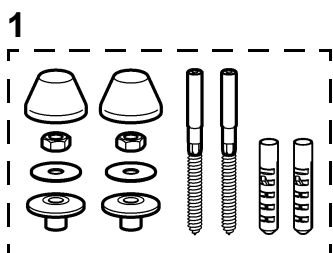

1..... 2030066440  
ESANW0005

2..... **450 mm:**  
2030046394  
ZANMW0023  
2030050886 <sup>a)</sup>  
ZANMW0027

**370 mm:**

2030051321  
ZANMW0024  
2030051360 <sup>a)</sup>  
ZANMW0028

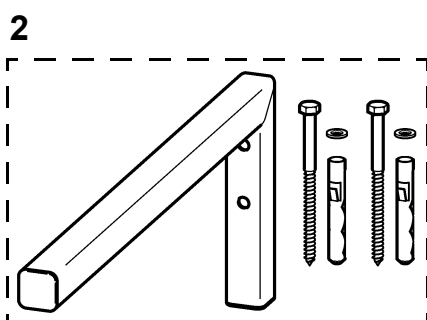

3..... 2000105048  
ZANMW0021  
2030051364 <sup>a)</sup>  
ZANMW0025

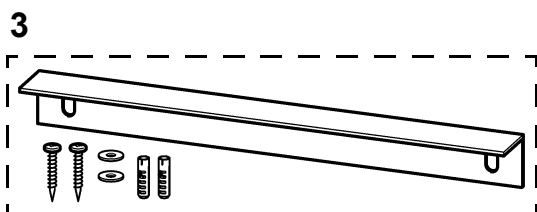

EN a) white  
(RAL9003)

ES a) Blanco  
(RAL9003)

PL a) Biały  
(RAL9003)

FI a) Valkoinen  
(RAL9003)

DE a) Weiß  
(RAL9003)

IT a) Bianco  
(RAL9003)

SV a) Vit  
(RAL9003)

RU a) белый  
(RAL9003)

FR a) Blanc  
(RAL9003)

NL a) Wit  
(RAL9003)

CS a) Bílá  
(RAL9003)



## 5. Zubehör I

EN Accessories  
FR Accessoire  
ES Accesorios  
IT Accessori

NL Toebehoren  
PL Akcesoria  
SV Tillbehör

CS Príslušenství  
FI Lisävarusteet  
RU принадлежности

### EXOS., EXOS. BF

1

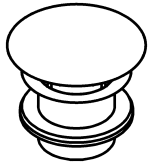

2

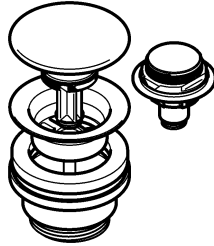

3



1..... 2000100861  
ZANMW900  
2..... 2030057337 <sup>b)</sup>  
ZANMW0030  
2030057339 <sup>c)</sup>  
ZANMW0031  
3600001266 <sup>d)</sup>  
ZANMW0050

4

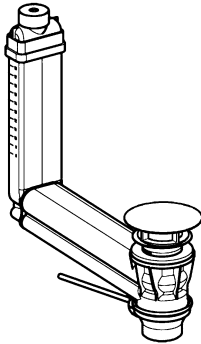

5

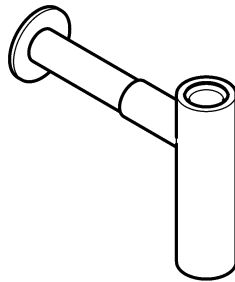

6



3..... 2000100854  
ZANMW901  
4..... 2000100932  
ZANMW902  
5..... 2000057417  
XINX140  
6..... 2000056721  
SD80

**EN** b) chromed  
c) white  
(RAL9003)  
d) stainless  
steel

**ES** b) Cromado  
c) Blanco  
(RAL9003)  
d) Acero  
inoxidable

**PL** b) Chromowany  
c) Biały  
(RAL9003)  
d) Stal  
nierdzewna

**FI** b) Kromattu  
c) Valkoinen  
(RAL9003)  
d) Ruostumaton  
teräs

**DE** b) verchromt  
c) weiß  
(RAL9003)  
d) Edelstahl

**IT** b) Cromato  
c) Bianco  
(RAL9003)  
d) Acciaio  
inossidabile

**SV** b) Kromat  
c) Vit  
(RAL9003)  
d) rostfritt stål

**RU** b) хромированная  
c) белый  
(RAL9003)  
d) нержавеющая  
сталь

**FR** b) Chromé  
c) Blanc  
(RAL9003)  
d) Acier  
inoxydable

**NL** b) Verchromd  
c) Wit  
(RAL9003)  
d) Roestvrij  
staal

**CS** b) Chromovaný  
c) Bílá  
(RAL9003)  
d) Nerezová  
ocel

## 6. Zubehör II

EN Accessories  
FR Accessoire  
ES Accesorios  
IT Accessori

NL Toebehoren  
PL Akcesoria  
SV Tillbehör

CS Příslušenství  
FI Lisävarusteet  
RU принадлежности

### EXOS., EXOS. BF

7

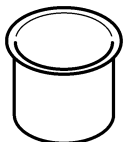

8

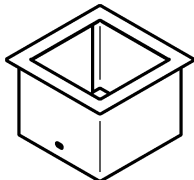

9

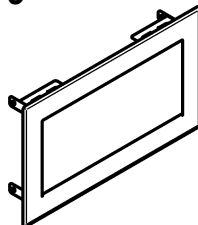

7 .....2000101106  
E-BS602E

8 .....2000101212  
RODX607TT

9 .....2000101211  
RODX605TT

10

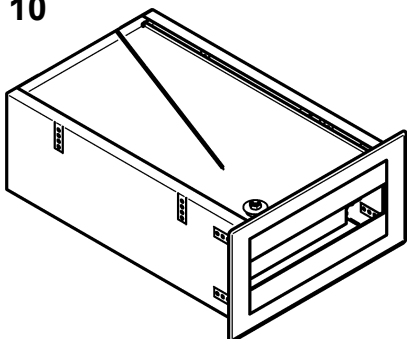

11

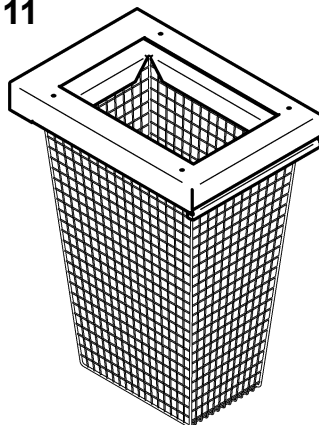

10 ...2000102672  
RODX600TT

11 ...2030053538  
ZANMW0042

### EXOS.

12

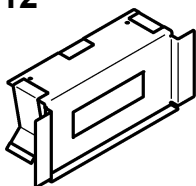

12 ...2030007912  
ZANMW0045

13 ...2030053539  
ZANMW0043

13

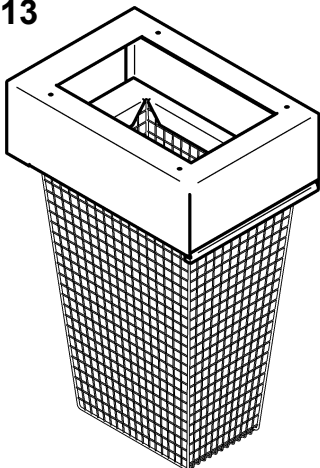

14

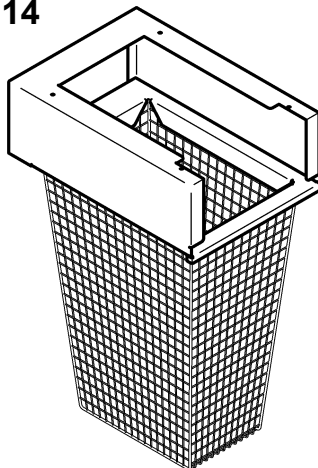

14 ...2030055226  
ZANMW0044

## 7. Zubehör III

EN Accessories  
FR Accessoire  
ES Accesorios  
IT Accessori

NL Toebehoren  
PL Akcesoria  
SV Tillbehör

CS Příslušenství  
FI Lisävarusteet  
RU принадлежности

15

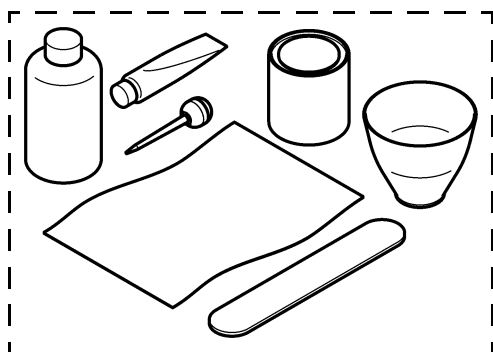

15 ...2000106178 <sup>e)</sup>  
EMONL0001  
2000106807 <sup>f)</sup>  
ZANMW0046  
2000106815 <sup>g)</sup>  
ZANMW0047  
2000111084 <sup>h)</sup>  
ZANMW0048

<b>EN</b>	e) Alpine White f) Granite black white g) Granite black h) Granite light grey	<b>ES</b>	e) Blanco Alpino f) Granito negro-blanco g) Granito negro h) Granito gris claro	<b>PL</b>	e) Biel Alpejska f) Granit czarny biały g) Granit czarny h) Granit jasnoszary	<b>FI</b>	e) Alpine White f) Graniitti musta valkoinen g) Graniitti musta h) Graniitti vaalean harmaa
<b>DE</b>	e) Alpinweiß f) Granit schwarz weiß g) Granit schwarz h) Granit hellgrau	<b>IT</b>	e) Bianco Alpino f) Granito nero bianco g) Granito nero h) Granito grigio chiaro	<b>SV</b>	e) Alpinvit f) Granit svart vit g) Granit svart h) Granit ljusgrå	<b>RU</b>	e) Альпийский белый f) Гранит черно-белый g) Гранит черный h) Гранит светло-серый
<b>FR</b>	e) Blanc Alpin f) Granit noir/blanc g) Granit noir h) Granit gris clair	<b>NL</b>	e) Alpinewit f) Graniet zwart/wit g) Graniet zwart h) Graniet lichtgrijs	<b>CS</b>	e) Alpská Bílá f) žula černobílý g) žula černá h) žula světle šedá		

**Australia**

PR Kitchen and  
Water Systems Pty Ltd  
Dandenong South VIC 3175  
Phone +61 3 9700 9100

**Austria**

KWC Austria GmbH  
6971 Hard, Austria  
Phone +43 5574 6735 0

**Belgium, Netherlands &  
Luxembourg**

KWC Aquarotter GmbH  
9320 Aalst; Belgium  
Phone NL +31 (0) 492 728 224  
BE/LU +32 (0) 53 60 31 50

**Czech Republic**

KWC Aquarotter GmbH  
14974 Ludwigsfelde, Germany  
Phone +49 3378 818 309

**France**

KWC Austria GmbH  
6971 Hard, Austria  
Phone +33 800 909 216

**Germany**

KWC Aquarotter GmbH  
14974 Ludwigsfelde  
Phone +49 3378 818 0

**Italy**

KWC Austria GmbH  
6971 Hard, Austria  
Numero Verde +39 800 789 233

**Middle East**

KWC ME LLC Ras Al Khaimah,  
United Arab Emirates  
Phone +971 7 2034 700

**Poland**

KWC Aquarotter GmbH  
14974 Ludwigsfelde, Germany  
Phone +48 58 35 19 700

**Spain**

KWC Austria GmbH  
6971 Hard, Austria  
Phone +43 5574 6735 211

**Switzerland & Liechtenstein**

KWC Group AG  
5726 Unterkulm, Switzerland  
Phone +41 62 768 69 00

**Turkey**

KWC ME LLC Ras Al Khaimah,  
United Arab Emirates  
Phone +971 7 2034 700

**United Kingdom**

KWC DVS Ltd - Northern Office  
Barlborough S43 4PZ  
Phone +44 1246 450 255

KWC DVS Ltd - Southern Office  
Paignton TQ4 7TW  
Phone +44 1803 529 021

**EAST EUROPE**

Bosnia Herzegovina  
Bulgaria | Croatia  
Hungary | Latvia  
Lithuania | Romania  
Russia | Serbia | Slovakia  
Slovenia | Ukraine

KWC Aquarotter GmbH  
14974 Ludwigsfelde, Germany  
Phone +49 3378 818 261

**SCANDINAVIA & ESTONIA**

Finland | Sweden | Norway  
Denmark | Estonia

KWC Nordics Oy  
76850 Naarajärvi, Finland  
Phone +358 15 34 111

**OTHER COUNTRIES**

**KWC Austria GmbH**  
**6971 Hard, Austria**  
**Phone +43 5574 6735 0**

