

KWC

Waschtischarmatur

Washbasin faucet

Miscelatore per lavandino

Robinetterie électronique pour lavabos

802223

(01/2013)



A 10

A 20

A 30

Montage/Bedienungsanleitung
Installation/User manual
Istruzioni di montaggio/per l'uso
Notice d'installation/d'utilisation

• **Richtlinien zur Installation**
 • **Direttiva per l' Installazione**

• **Installation guidelines**
 • **Directives d'installation**

- | | | | |
|--|---|--|--|
| <ul style="list-style-type: none"> • Wasserleitungsdrücke von Warmwasser und Kaltwasser müssen gleich sein. • Installation und Lagerung nur in frostsicheren Räumen. | <ul style="list-style-type: none"> • The water pressure for both the hot and cold water pipes should be equal. • Install and store in frost-proof rooms only. | <ul style="list-style-type: none"> • Si prega di osservare le norme esistenti per l'installazione e l'allacciamento all'impianto idrico. • Si consiglia l'installazione con pressioni dell'acqua calde e fredde equilibrate. | <ul style="list-style-type: none"> • Respecter les normes en vigueur et les conditions de raccordement au réseau d'eau local. • L'eau chaude et l'eau froide doivent avoir la même pression. |
| <ul style="list-style-type: none"> • Ab Datum des Erwerbes (Kaufbeleg) gewähren wir eine Garantie von 2 Jahren. | <ul style="list-style-type: none"> • We will guarantee the products for 2 years from the date of acquisition. | <ul style="list-style-type: none"> • Garantiamo il prodotto per 2 anni dalla data di acquisto. | <ul style="list-style-type: none"> • Nous accordons une garantie de 2 ans sur les produits à partir de la date d'achat (ticket de caisse). |

• **Installation**
 • **Installazione**

• **Installation**
 • **Installation**

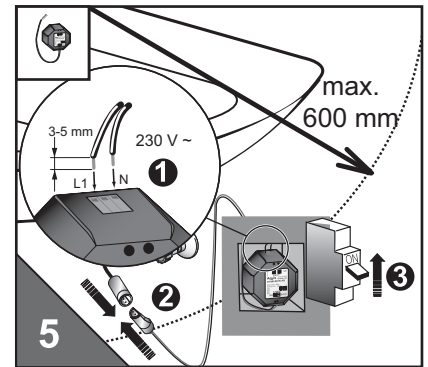
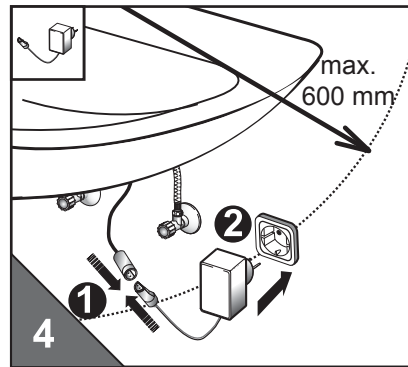
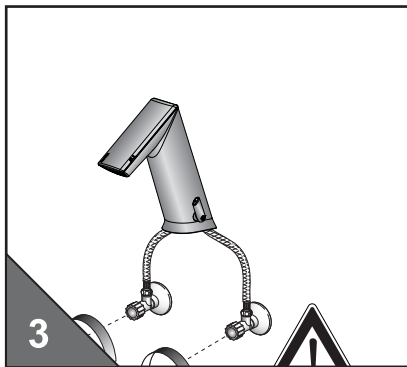
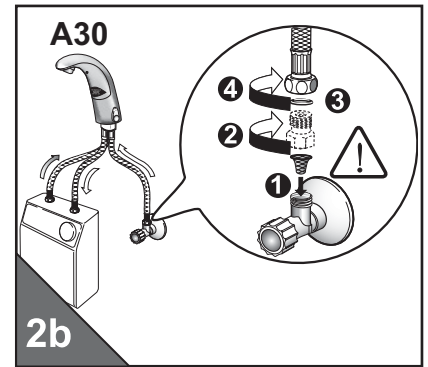
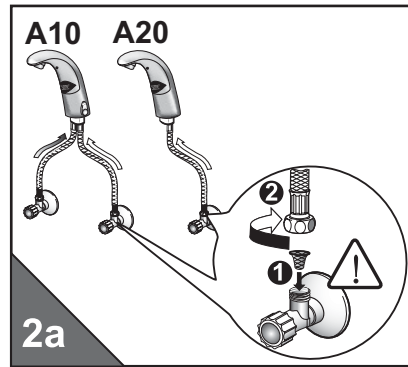
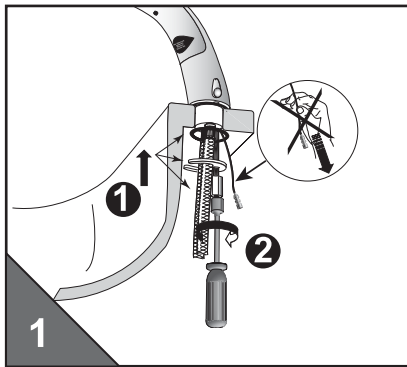

- Wassermenge einstellen!
- Adjust water quantity!
- Regolazione acqua!
- Régler la quantité d'eau!

- Spannungsversorgung herstellen
- Connect to the power supply
- Stabilire l'alimentazione di tensione
- Etablir l'alimentation électrique

- Spannungsversorgung herstellen
- Connect to the power supply
- Stabilire l'alimentazione di tensione
- Etablir l'alimentation électrique

- Inbetriebnahme
- Messa in funzione

- Preparing for operation
- Mise en service

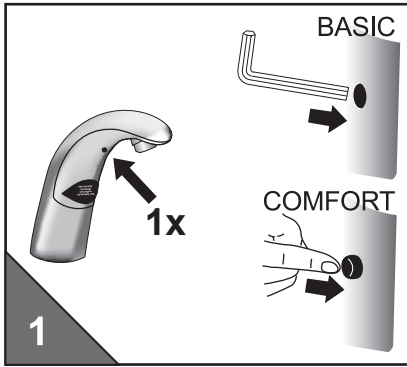

1x Taste drücken...Aufkleber entfernen...
 Press the key once...remove sticker...
 Premere il tasto 1x... Rimuovere adesivo...
 Appuyez 1x sur la touche... Retirez
 l'autocollant...

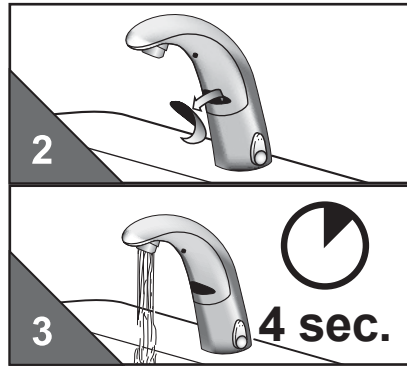

...Wasser fließt ca. 4 sec....
 ...water flows for approx. 4 sec....
 ...l'acqua scorre per ca. 4 sec...
 ...l'eau coule env. 4 sec....

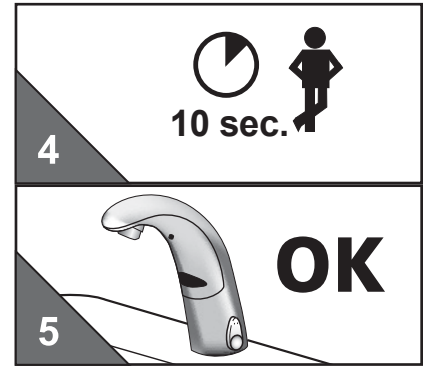

...10 sec. warten - betriebsbereit
 ...wait 10 sec. - ready for use
 ...attendere 10 sec. - pronto per il servizio
 ...attendez 10 sec. - opérationnel

- Funktionen
- Funzioni

- Wasser „Ein“
- Water flow „On“
- Flusso aperto
- Ecoulement ouvert

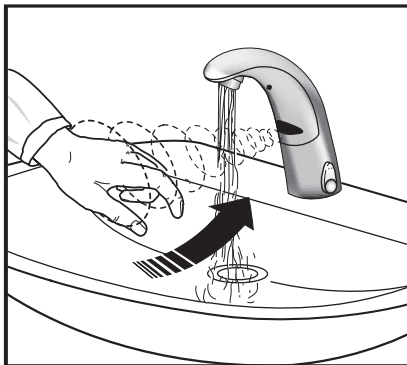

- Functions
- Fonctions

- Wasser „Aus“
- Water flow „Off“
- Flusso chiuso
- Ecoulement fermé

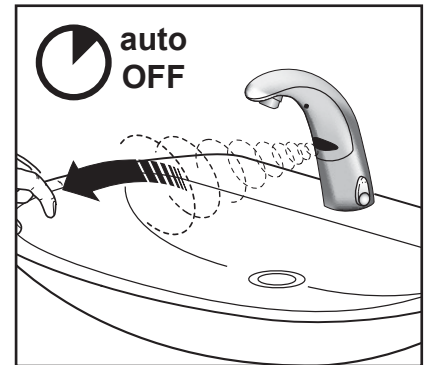

- Temperatureinstellung
- Impostazione della temperatura

- Adjusting the temperature
- Réglage de la température

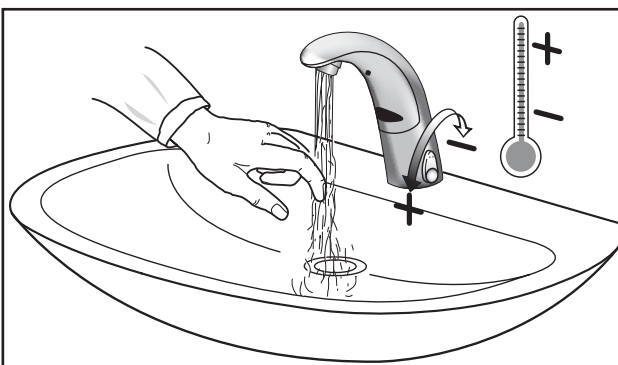

- iqua-Klick (Komfort-Taste)
- iqua-Klick (Comfort-tasto)

- Dauer Ein
- Continuous On
- Continou On
- Ecoulement continu

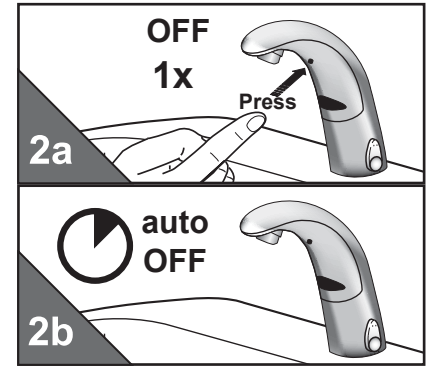
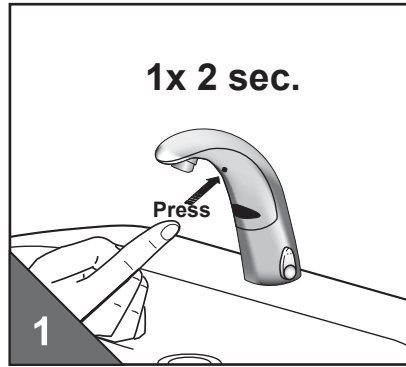

- „Kurz Aus“
- „Intermittent Off“
- Possibilità di interruzione del funzionamento
- Interruption brève

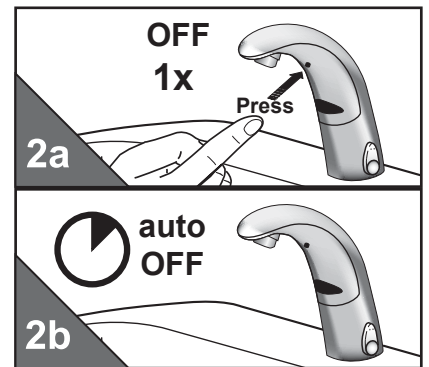
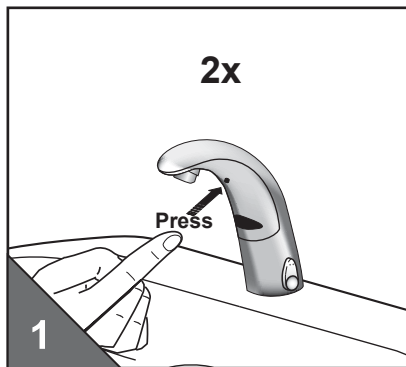

- Wassernachlaufzeit einstellen
- Changing Time of water flow
- Impostare il tempo di coda dell'acqua
- Réglage du post-écoulement de l'eau

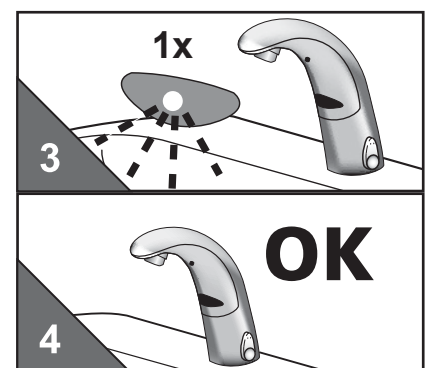
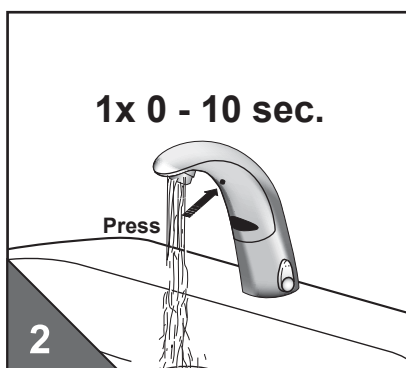
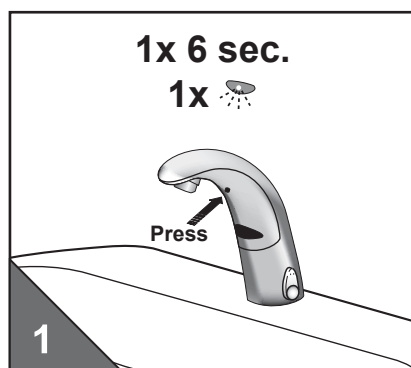

- Taste 6 sec. drücken, loslassen...
- Press the key for approx. 6 sec. Release...
- Premere il tasto per ca. 6 sec. poi rilasciarlo...
- Appuyez pendant env. 6 sec. sur la touche, relâchez...

- ...erneut drücken, Wasser „EIN“, 0 - 10 sec. gedrückt halten, loslassen
- ...press again. Hold down water „ON“ for 0 - 10 sec. Release.
- ...premere nuovamente, tenere premuto acqua „ON“ per 0 - 10 sec., poi rilasciarlo
- ...appuyez à nouveau, „Ecoulement ouvert“, tenez la touche enfoncée 0 - 10 sec., relâchez

- **Wasserlaufzeit: „Dauer-Ein“ und „12/24 Stunden Hygienespülung“**
- **Water flow duration: „Continuous On“ and „12/24 hours automatic flush“**
- **Durata acqua: „Continuo On“ e „Scarico forzato ogni 12/24 ore“**
- **Période de l'eau: „Ecoulement Continu“ e „Rinçage forcé 12/24 heures“**

- Wasserlaufzeit: „12/24 Stunden Hygienespülung“ entspricht „Dauer-Ein“
- Water flow duration: „12/24 hours automatic flush“ equates to „Continuous On“
- Durata acqua: „Scarico forzato ogni 12/24 ore“ equivale a „Continuo On“
- Période de l'eau: „Rinçage forcé 12/24 heures“ équivaut à „Ecoulement Continu“

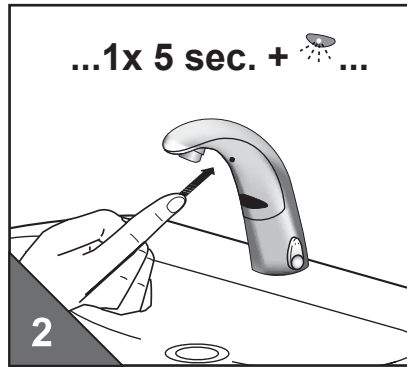
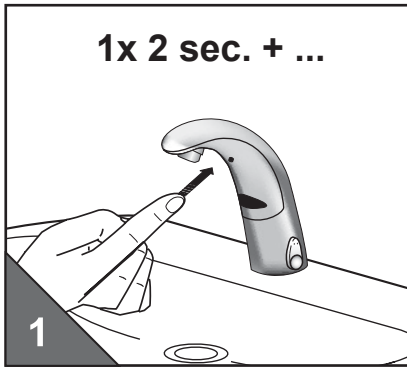

...1x		= 0,5 min
...2x		= 1,0 min
...3x		= 1,5 min
...
...38x		= 19,0 min
...39x		= 19,5 min
...40x		= 20,0 min

- Taste 2 sec. drücken, loslassen...
- Press the key for 2 sec. Release...
- Premere il tasto per 2 sec. poi rilasciarlo...
- Appuyez pendant 2 sec. sur la touche, relâchez...

- ...erneut drücken und gedrückt halten ...
- ...press again and hold down...
- ...premere nuovamente e tenere premuto...
- ...appuyez à nouveau et tenez la touche enfoncée ...

- ...nach gewünschter Laufzeit loslassen.
- ...release after the required flow duration.
- ...rilasciare dopo il tempo di scorrimento desiderato.
- ...relâchez après la durée souhaitée.

- **12/24 Stunden Hygienespülung**
- **Scarico forzato ogni 12/24 ore**

- **12/24 hours automatic flush**
- **Rinçage forcé 12/24 heures**

- Wasserlaufzeit: „12/24 Stunden Hygienespülung“ entspricht „Dauer-Ein“
- Water flow duration: „12/24 hours automatic flush“ equates to „Continuous On“
- Durata acqua: „Scarico forzato ogni 12/24 ore“ equivale a „Continuo On“
- Période de l'eau: „Rinçage forcé 12/24 heures“ équivaut à „Ecoulement Continu“

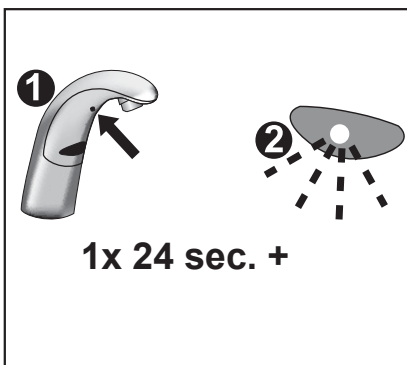

		h
• deaktivieren • deactivate • disattivare • désactiver	1x	----
• aktivieren • activate • attivare • activer	2x	12 h
	3x	24 h

- 1x 24 sec. Taste drücken bis...
- Press key 1x 24 sec. until...
- Premere il tasto brevemente 1x 24 sec. finché...
- Appuyez pendant env. 1x 24 sec. sur la touche jusqu'à ce que...

- ...LED 1 - 3x blinkt - Taste loslassen...
- ...LED flashes 1 - 3x - Release...
- ...il LED non lampeggia 1 - 3x - rilasciare...
- ...la LED clignote 1 - 3x - relâchez...

- ...betriebsbereit
- ...ready for use
- ...pronto per il servizio
- ...opérationnel

- Automatische Sensoreinmessung
- Misurazione automatica

- Automatic sensor adjustment
- Réglage automatique de la cellule

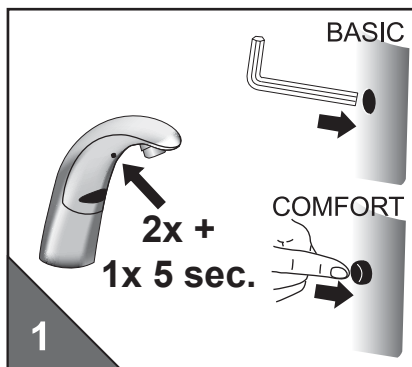

- 2x kurz und 1x 5 sec. Taste drücken bis...
- Press key twice, press again and hold down for app. 5 sec. until...
- Premere il tasto brevemente 2x e 1x per 5 sec. finché...
- Appuyez 2x brièvement et 1x pendant 5 sec. sur la touche jusqu'à ce que...

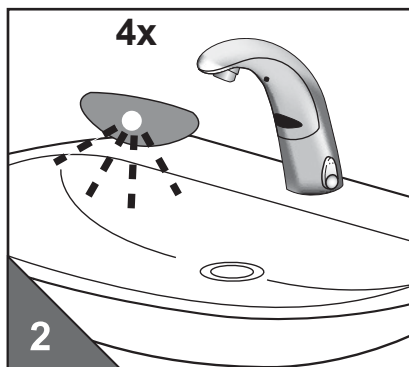

- ...LED 4x blinkt - Taste loslassen...
- ...LED flashes 4x. Release...
- ...il LED lampeggia 4x - rilasciare...
- ...la LED clignote 4x - relâchez...

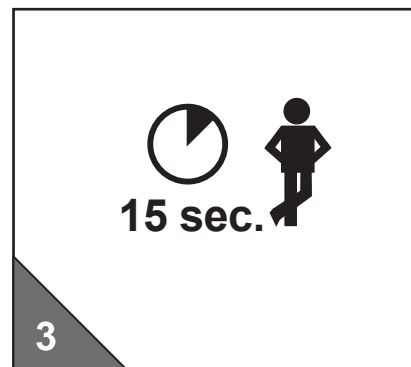

- ...15 sec. warten...
- ...wait 15 sec.
- ...aspettare 15 sec.
- ...attendre 15 sec.



- ...Wasser fließt ca. 4 sec....
- ...Water flows for approx. 4 sec....
- ...L'acqua scorre per ca. 4 sec...
- ...L'eau coule env. 4 sec....

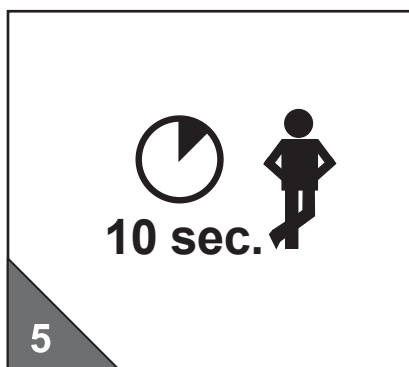

- ...10 sec. warten...
- ...wait 10 sec....
- ...attendere 10 sec....
- ...attendez 10 sec....



- ...betriebsbereit
- ...ready for use
- ...pronto per il servizio
- ...opérationnel

• Einstellung der Sensorreichweite • **Setting the sensor range**
• Impostazione della portata del sensore • **Réglage de la portée du détecteur**

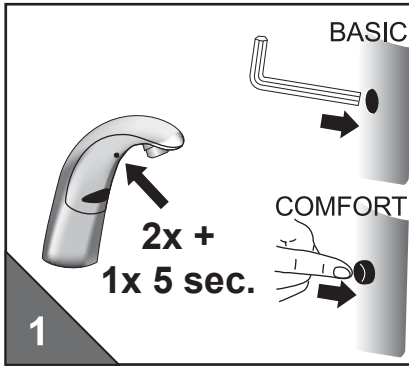

- 2x kurz und 1x 5 sec. Taste drücken bis...
- Press key twice, press again and hold down for app. 5 sec. until...
- Premere il tasto brevemente 2x e 1x per 5 sec. finché...
- Appuyez 2x brièvement et 1x pendant 5 sec. sur la touche jusqu'à ce que...

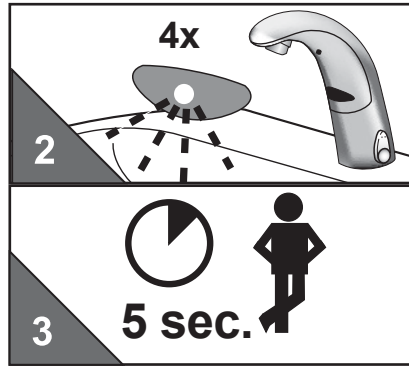

- ...LED 4x blinkt - Taste gedrückt halten...
- ...LED flashes 4x - hold pressed...
- ...il LED lampeggia 4x - e tenere premuto...
- ...la LED clignote 4x - et tenez la touche enfoncée...

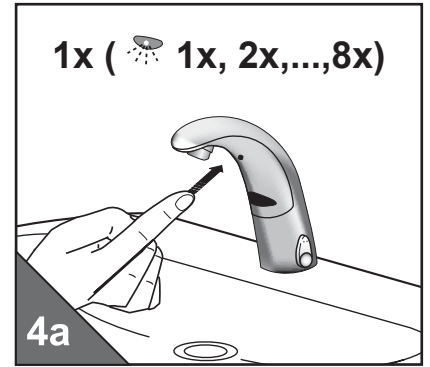

- ...Taste drücken bis LED blinkt...
- ...hold down the key until the LED flashes...
- ...premere il tasto finché il LED lampeggia...
- ...appuyez sur la touche jusqu'à ce que la LED clignote...

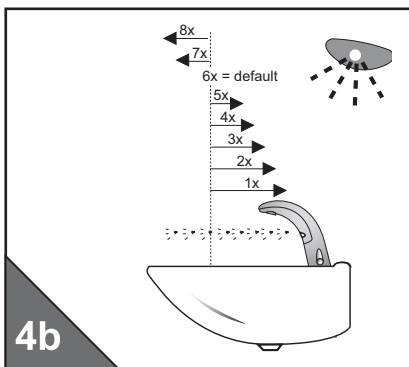

- LED blinkt: 1x = min....8x = max., loslassen
- LED flashes: 1x = min....8x = max., release
- LED lampeggia: 1x = min....8x = max., rilasciare
- LED clignote: 1x = min....8x = max., relâchez

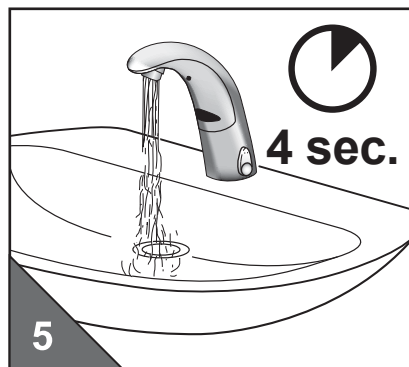

- ...Wasser fließt ca. 4 sec....
- ...water flows for approx. 4 sec....
- ...l'acqua scorre per ca. 4 sec...
- ...l'eau coule env. 4 sec....

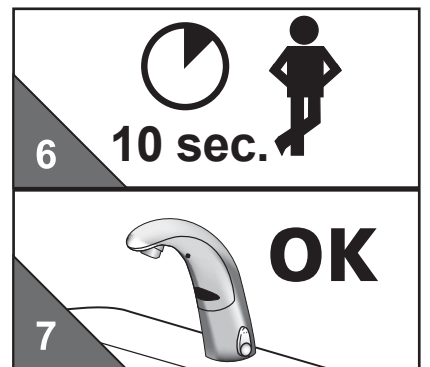

- ...10 sec. warten - betriebsbereit
- ...wait 10 sec., ready for use
- ...attendere 10 sec. - pronto per il servizio
- ...attendez 10 sec. - opérationnel

• Temperatur Fixeinstellung • **Fixed temperature setting**
• Temperatura impostazione fissa • **Réglage fixe de la température**

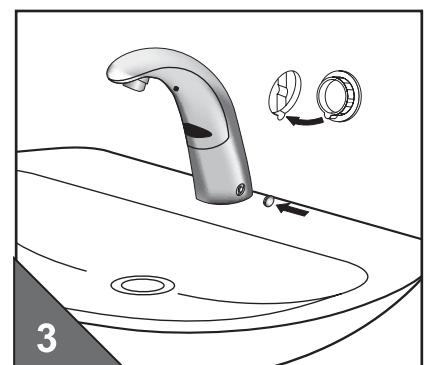
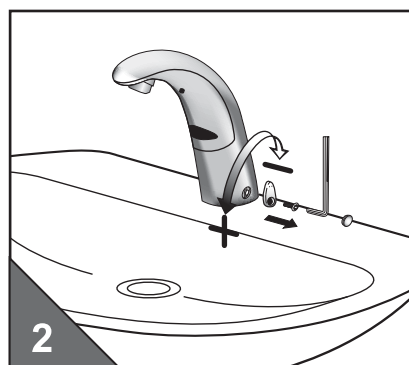
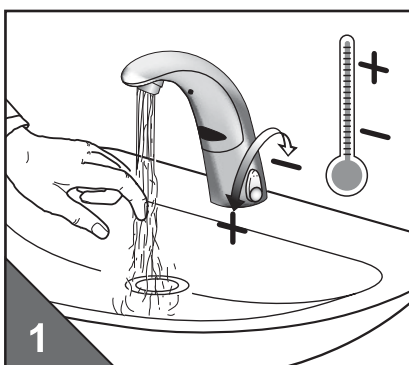

- A10 - Heisswassersperre einstellen
- A10 - Adjusting the hot water limitation
- A10 - Impostare il blocco dell'acqua calda
- A10 - Réglage du robinet d'eau chaude

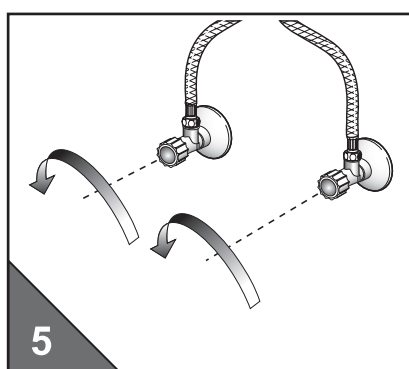
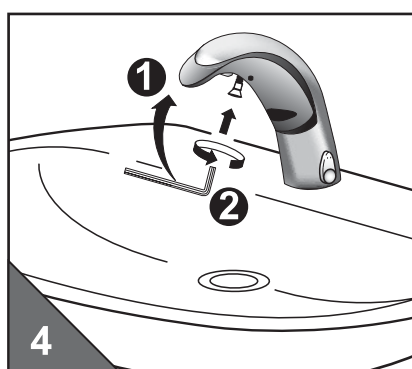
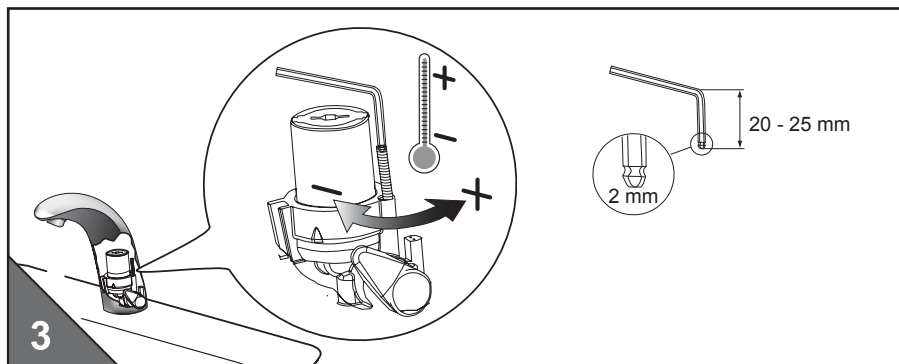
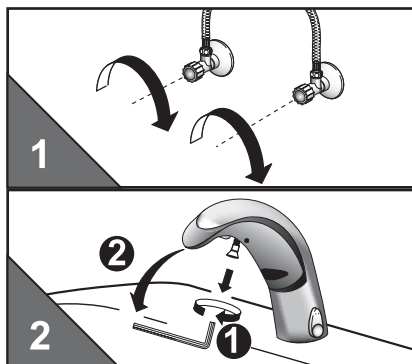

- Schmutzsieb-Reinigung
- Pulire il filtro

- Cleaning the filters
- Nettoyage du tamis

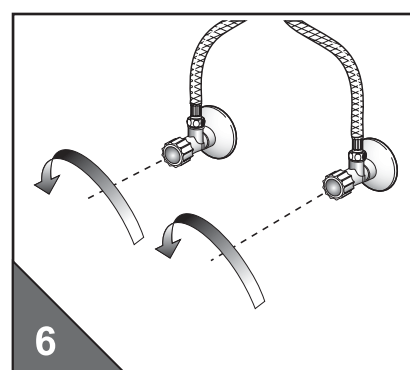
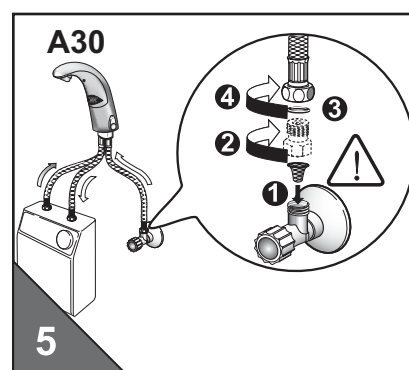
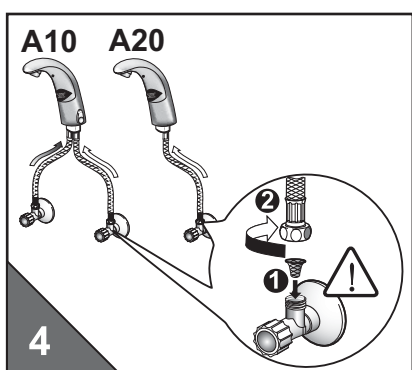
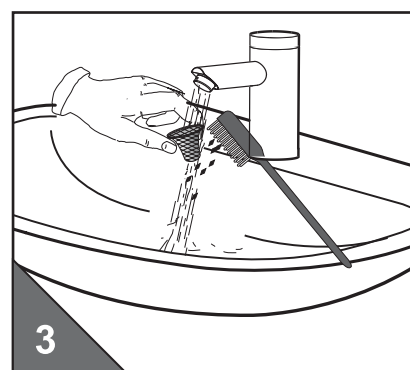
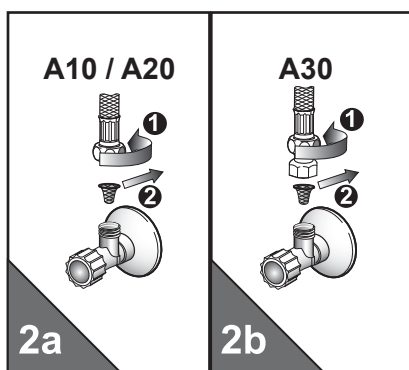
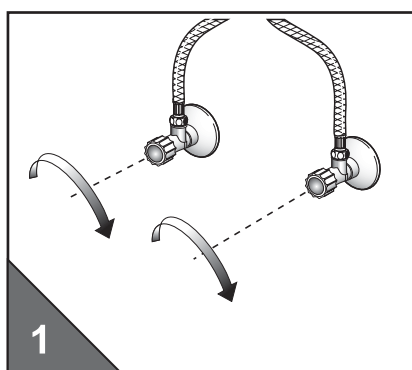

- Batteriewechsel
- Cambio batteria

- Changing the battery
- Remplacer la pile

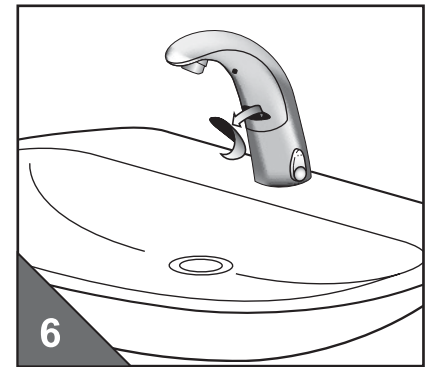
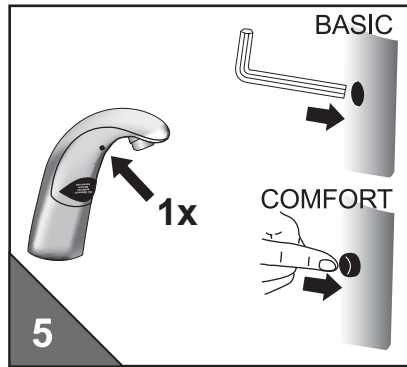
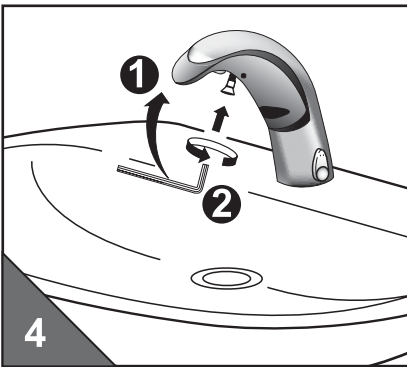
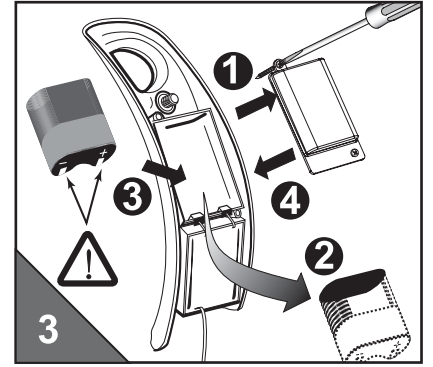
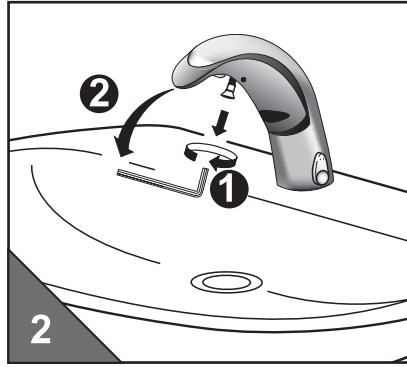
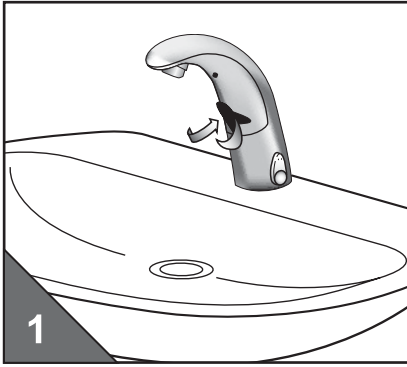

• Systemübersicht
• Vista generale del sistema

• System overview
• Résumé du système

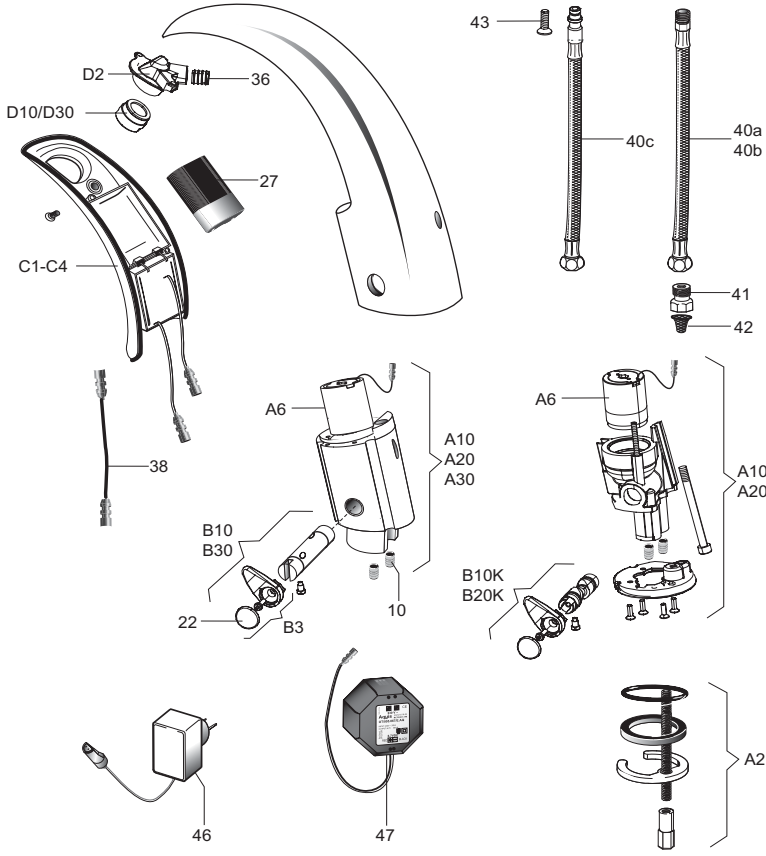
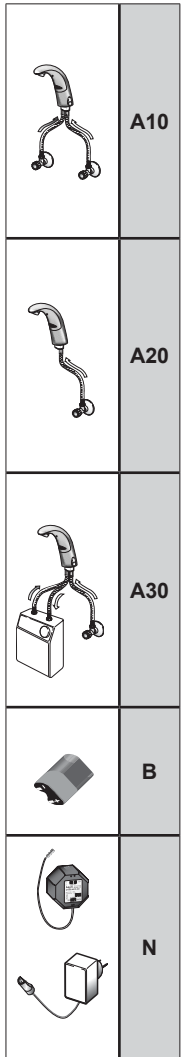

10	Z.501.993	A10, A20	B, N
22	Z.633.377	A10, A20, A30	B, N
27	Z.534.282	A10, A20, A30	B
38	Z.534.285	A10, A20, A30	N
41	Z.536.783	A30	B, N
42	Z.633.376	A10, A20, A30	B, N
43	Z.636.766	A10, A20	B, N
46	Z.534.291	A10, A20, A30	N
47	Z.534.292	A10, A20, A30	N
40c	Z.536.784	A10, A20	B, N
A6	Z.534.286	A10, A20, A30	B, N
B10K	Z.534.784	A10	B, N
B3	Z.534.294	A10, A20, A30	B, N
B30	Z.536.789	A30	B, N
C1(comfort)	Z.534.287	A10, A20, A30	B
C2(basic)	Z.534.289	A10, A20, A30	B
C3(comfort)	Z.534.288	A10, A20, A30	N
C4(basic)	Z.534.290	A10, A20, A30	N
D10	Z.505.344	A10, A20	B, N
D2	Z.535.305	A10, A20, A30	B, N
D30	Z.536.790	A30	B, N

• Technische Daten • Technical Data • Dati tecnici • Données techniques

Batteriebetrieb	Battery operation	Funzionamento a batterie	Fonctionnement sur batterie	6 VDC
Netzbetrieb	Mains supply	Funzionamento con alimentazione di rete	Fonctionnement sur secteur	230 VAC / 6 VDC
Betriebsdruck	Operating pressure	Pressione di esercizio	Pression de service	0,3 - 10 bar
Durchflussmenge	Flow volume	Portata	Débit	ca. 6,5 l/min (3bar)
Wassertemperatur	Water temperature	Temperatura dell'acqua	Température de l'eau	max. 80 °C
Wassernachlaufzeit (Werkseinstellung)	Follow up time (factory setting)	Tempo di coda dell'acqua (impostazione di fabbrica)	Post-écoulement de l'eau (réglage d'usine)	1 sec.
Wasserlaufzeit: „12/24 Stunden Hygienespülung“ entspricht „Dauer-Ein“	Water flow duration: „12/24 hours automatic flush“ equates to „Continuous On“	Durata acqua: „Scarico forzato ogni 12/24 ore“ equivale a „Continuo On“	Période de l'eau: „Rinçage forcé 12/24 heures“ équivaut à „Ecoulement Continu“	0,5 - 20 min.

• Störungsbehebung

Störung / Fehler	Mögliche Ursache	Behebung
Armatur spült nicht	<ul style="list-style-type: none"> • „Kurz-Aus“ ist aktiviert • Absperrventil geschlossen bzw. Schmutzsieb verstopft • Batterie leer • Stromausfall / Netzteil defekt 	<ul style="list-style-type: none"> • „Kurz-Aus“ beenden • Absperrventil öffnen bzw. Schmutzsieb reinigen • Batterie austauschen • Stromversorgung prüfen
Armatur spült selbstständig (ohne Benutzung)	<ul style="list-style-type: none"> • Reflexion an Gegenständen 	<ul style="list-style-type: none"> • Automatische Einmessung
Wasser fließt permanent	<ul style="list-style-type: none"> • Ventil defekt 	<ul style="list-style-type: none"> • Kundendienst kontaktieren
Rote LED blinkt	<ul style="list-style-type: none"> • Batterie leer 	<ul style="list-style-type: none"> • Batterie austauschen

• Trouble shooting

Function	Cause	Solution
Valve does not flush	<ul style="list-style-type: none"> • „Intermittent off“ is activated • Stop valve closed or filter clogged • Battery flat • Power failure 	<ul style="list-style-type: none"> • End „intermittent off“ • Open stop valve or clean filter • Change battery • Check power supply
Valve flushes uncontrolled (without use)	<ul style="list-style-type: none"> • Reflection 	<ul style="list-style-type: none"> • Automatic sensor adjustment
Water flows permanently	<ul style="list-style-type: none"> • Valve defect 	<ul style="list-style-type: none"> • Call Customer Service
Red LED flashes	<ul style="list-style-type: none"> • Battery flat 	<ul style="list-style-type: none"> • Change battery

• Difetti di funzionamento

Difetto / errore	Possibili cause	Soluzioni
L'orinatoio non sciacqua	<ul style="list-style-type: none"> • „Arresto temporaneo“ attivato • Valvola d'intercettazione chiusa o filtro intasato • Batteria esaurita • Breve interruzione di corrente 	<ul style="list-style-type: none"> • „Arresto temporaneo“ terminato • Aprire la valvola d'intercettazione o pulire il filtro • Cambiare la batteria • Verificare l'alimentazione elettrica
L'orinatoio si attiva autonomamente (senza essere stato usato)	<ul style="list-style-type: none"> • Riflesso 	<ul style="list-style-type: none"> • Misurazione automatica
L'acqua scorre continuamente	<ul style="list-style-type: none"> • Valvola difettosa 	<ul style="list-style-type: none"> • Servizio Assistenza
LED rosso lampeggia	<ul style="list-style-type: none"> • Batteria esaurita 	<ul style="list-style-type: none"> • Cambiare la batteria

• Elimination des perturbations

Perturbation / Erreur	Cause possible	Solution
Aucun déclenchement	<ul style="list-style-type: none"> • «Arrêt bref» activé • Soupape d'arrêt fermée ou tamis bouché • Pile usée • Panne de courant 	<ul style="list-style-type: none"> • Terminer «Arrêt bref» • Ouvrir la soupape d'arrêt ou nettoyer le tamis • Remplacer la pile • Contrôler l'alimentation en courant
L'eau coule d'elle-même (sans que l'urinoir soit utilisé)	<ul style="list-style-type: none"> • Reflet 	<ul style="list-style-type: none"> • Réglage automatique de la cellule
L'eau coule en permanence	<ul style="list-style-type: none"> • Soupape défectueuse 	<ul style="list-style-type: none"> • Contacter le service après-vente
la cellule LED clignote	<ul style="list-style-type: none"> • Pile utilisé 	<ul style="list-style-type: none"> • Remplacer la pile

• Pflege • Maintenance • Cura • Entretien holdelse

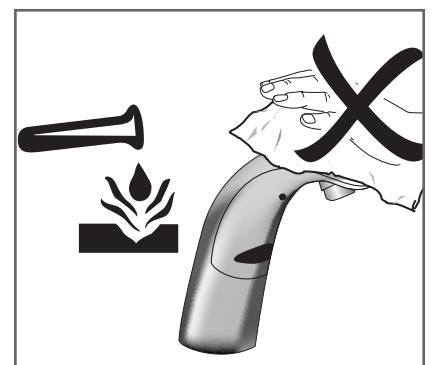
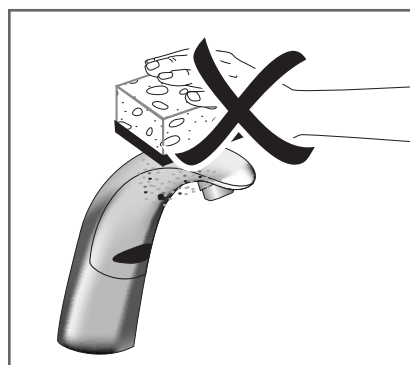
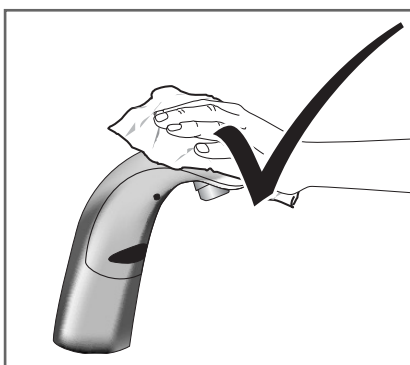

KWC VG
KWC Deutschland GmbH
Junghansring 70
DE-72108 Rottenburg
+49 (0) 7457 948 56 0
+49 (0) 7457 948 56 30

Franke WS
Franke GmbH
Oberer Achdamm 52
AT-6971 Hard
+43 (0) 557 467 350
+43 (0) 557 462 411

Franke KS
Franke GmbH
Mumpferfährstrasse 70
DE-79713 Bad Säckingen
+49 (0) 7761 52 0
+49 (0) 7761 52 294

KWC VG
KWC Italia S.r.l.
Via Vecchia Ferriera 59/B
IT-36100 Vicenza
+39 (0) 444 566 618
+39 (0) 444 961 519

Franke WS/KS
Franke L.L.C.
RAK Industrial Zone, P.O. Box 14511
AE-Ras Al Khaimah, UAE
+971 7 203 47 00
+971 7 203 47 60

Franke KS
Franke France S.A.S.
Avenue Aristide Briand BP 13
FR-60230 Chambly
+331 30 28 94 00
+331 30 28 94 30

KWC VG
KWC AMERICA
1770 Corporate Drive #580
Norcross, GA 30093 USA
+1 678 334 21 21
+1 678 334 21 28

Franke WS
Franke Washroom Systems
Ring-Oost 10
BE-9400 Ninove
+32 (0) 54 31 01 30
+32 (0) 54 31 01 35

Franke KS
Franke UK Limited
West Park, MIOC, Styal Road
GB-Manchester M22 5WB
+44 161 436 62 80
+44 161 437 13 79

Franke KS
Franke NV
Ring 10
BE-9400 Ninove
+32 (0) 54 31 01 11
+32 (0) 54 32 36 88

Franke KS
Franke Nederland B.V.
Lagedijk 13
NL-5705 Bx Helmond
+31 492 585 111
+31 492 585 200

